

Technical Product Manual

VDO cockpit vision
VDO cockpit international

Technical Product Manual

VDO cockpit vision VDO cockpit international

Published by:
Siemens VDO Trading GmbH
Trading & Aftermarket

P.O.Box 62 01 27
D-60350 Frankfurt/M

Kruppstraße 105
D-60388 Frankfurt/M

This documentation comes under the copyright of the Siemens VDO Trading GmbH. It cannot be copied without previous written permission by the Siemens VDO Trading GmbH nor used in contradiction to their privileged interests.

Technical Product Manual

VDO cockpit vision VDO cockpit international

Overview Of Chapters

Subject		Chapter
General informations	VDO cockpit vision VDO cockpit international	1
Electronic speedometer dia.80 mm / dia.100 mm	VDO cockpit vision VDO cockpit international	2
Electronic tachometer dia.80 mm / dia.100 mm	VDO cockpit vision VDO cockpit international	3
Electronic tachometer with operating hours counter dia.80 mm / dia.100 mm	VDO cockpit international	4
Electronic tachometer dia.52 mm	VDO cockpit vision VDO cockpit international	5
Electric pressure gauge dia.52 mm	VDO cockpit vision VDO cockpit international	6
Electric oil temperature gauge dia.52 mm	VDO cockpit vision VDO cockpit international	7
Electric fuel level gauge (fuel level sensor, lever type) dia.52 mm	VDO cockpit vision VDO cockpit international	8
Electric fuel level gauge (fuel level sensor, tubular type) dia.52 mm	VDO cockpit vision VDO cockpit international	9

Technical Product Manual

VDO cockpit vision VDO cockpit international

Overview Of Chapters

Subject		Chapter
Voltmeter dia.52 mm	VDO cockpit vision VDO cockpit international	10
Ammeter dia.52 mm	VDO cockpit vision VDO cockpit international	11
Electric clock dia.52 mm	VDO cockpit vision VDO cockpit international	12
Electronic operating hours counter dia.52 mm	VDO cockpit international	13
Temperature measuring system for exterior temperature dia.52mm	VDO cockpit vision VDO cockpit international	14
Mechanical pressure gauge dia.52 mm	VDO cockpit vision VDO cockpit international	15
Mechanical temperature gauge dia.52 mm	VDO cockpit international	16
Final Assembly	VDO cockpit vision VDO cockpit international	17
Spare parts and accessories	VDO cockpit vision VDO cockpit international	18
Pyrometer (exhaust-gas temperature measuring system) dia. 52 mm	VDO cockpit international	19

Technical Product Manual

VDO cockpit vision VDO cockpit international

1. General Informations

Contents

Page

1.1	VDO cockpit vision	1 - 2
1.2	VDO cockpit international	1 - 3
1.3	Safety instructions	1 - 4
1.3.1	Installation	1 - 4
1.3.2	Electrical connection	1 - 5
1.3.3	Assembly	1 - 5

Technical Product Manual

VDO cockpit vision VDO cockpit international

1. General Informations

1.1 VDO cockpit vision

Backlight

Rated voltage: 12-volt or 24-volt

Design

Bezel: brass, black, rectangular version

Lens: nonreflective

Deflector: black

Dial: plastic (polycarbonat) for translucent backlighting
dialgraphics: black background with white characters

Pointer: plastic (polycarbonat) for translucent backlighting,
red, for high temperature

Housing: plastic (flame retardant) 52 mm / 80 mm / 100 mm diameter
or
steel, zinc-plated and chromitized (ammeter, turbocharger gauge)

Mounting: bracket, steel, zinc-plated and chromitized
or
clamp ring, plastic

Illumination: backlight
clear
or
variable (green and red colour caps)

Connections: blade connectors 6.3 x 0.8 mm
exception: Ammeter (screw connection)

Marking (label):

manufacturer, country of origin
production date
rated voltage
part number(s)
specific: CE sign, resistance value

(Supersedes VDO cockpit and VDO mobilcockpit)

Technical Product Manual

VDO cockpit vision VDO cockpit international

1. General Informations

1.2 VDO cockpit international

Floodlight

Rated voltage: 12-volt or 24-volt

Design

Bezel:	brass, black, triangular version
Lens:	nonreflective
Deflector:	black
Dial:	aluminium for instrument housing diameter 52 mm or plastic for instrument housing diameter 80 mm / Ø 100 mm dialgraphics: black background with white characters
Pointer:	aluminium, red (pointer hub: plastic, black)
Housing:	steel, zinc-plated and chromated or plastic (diameter 52 mm: tachometer, clock, operating hours counter, pyrometer; diameter 80 mm / 100 mm: all instruments)
Mounting:	bracket, steel zinc-plated and chromated or clamp ring, plastic (plastic instruments)
Illumination:	floodlight clear (operating hours counter without illumination)
Connections:	blade connectors 6.3 x 0.8 mm exception: ammeter (screw connection)

Marking (label):

manufacturer, country of origin
production date
rated voltage
part number(s)
specific: CE sign, resistance value

(Supersedes VDO proficockpit)

Technical Product Manual

VDO cockpit vision VDO cockpit international

1. General Informations

1.3 Safety Instructions

1.3.1 Installation



- The product was developed, manufactured and inspected in compliance with the basis safety reof the EC Directives and in accordance with the generally recognised present level of technology. The product must only be used for service in land-bound vehicles (with the exception of motorcycles) or in stationary systems.

Prior to installation of the product, please observe the following instructions:

- For proper installation of the product, basic knowledge of motor vehicle electrical and mechanical equipment is required in order to prevent damage.
- Write down all the data of volatile electronic memories.
- Remove the ignition key from the ignition lock. Then disconnect the minus pole of the battery (including the minus pole of any auxiliary batteries).
When the minus pole of the batteries are disconnected, all volatile electronic memories lose their input values.
- Failure to disconnect the minus pole of the battery can cause short-circuits in the vehicle electrical system and then result in cable fires, battery explosions and damage to other electronic systems.
- Prior to installation of the product, refer to the motor vehicle registration documents for information on the vehicle type and any special equipment features and refer to the design plans for further information on the positions of fuel, hydraulic, compressed-air and electrical lines.
- Use the product as intended. Do not change or modify.
Improper use, alteration or modification of the product can result in injuries, property damage or environmental damage or have an effect on safety.

During installation of the product, please observe the following instructions:

- Observe the safety instructions of the manufacturers of the vehicle, system, motor and tools in each instance!
- Select the installation location so that the product and its components:
 - do not affect or hinder any functions of the vehicle or system.
 - are not damaged by any functions of the vehicle or system.
 - do not obstruct the driver's view.
 - are not positioned in locations where the driver and front-seat passenger can strike their heads in case of an accident.
 - are not positioned in the mechanical and electrical airbag area.
 - have sufficient clearance behind the drilled holes or installation opening.
- Do not make drilled holes or installation openings in supporting or stabilising braces or struts!

Following installation of the product, please observe the following instructions:

- Connect the ground cable firmly to the minus pole of the battery.
- Enter / program the values of the volatile memories again.
- Check all (!) vehicle functions.
- When measuring the voltages and currents in the vehicle, only use multimeters or diode testing lamps that are designed to be used for such measurements. The use of conventional testing lamps can cause damage to the control units or other electronic systems.

Special cases:

- Please be extremely careful whenever you must perform any required work on the running motor. Wear suitable working clothes only, since risk of suffering injuries such as bruises or burns exists. If your hair is long, wear a hairnet.

1.3 Safety Instructions

Technical Product Manual

VDO cockpit vision VDO cockpit international

1. General Informations

1.3.2 Electrical Connection

Connect the cables according to the electrical terminal connection diagram.
Incorrect terminal connections can cause in short-circuits!



Safety instructions:

- Danger of short-circuits due to defective connecting points or pinched cables!
All connections of the voltage supply system must therefore be soft-soldered or provided with weldable joint connectors and sufficiently insulated.
You may use commercially available standard-type crimp connectors to make other connections.
Make sure the ground connections are perfectly made!
Insulate any cable ends that are not required!
- Take the cable diameter into account!
A reduction of the cable diameter will result in higher current density. This can cause overheating of the affected cable section!
- Cables must be stripped using a wire stripper only. Adjust the wire stripper to prevent any strands from being damaged or cut off!
- Crimped connections must be made using a pair of cable crimping pliers only.
- When installing the cables, use the existing cable conduits and cable harnesses, but do not install the cables parallel to the ignition cables or cables that run over to high-capacity power consumers! Fasten the cables with cable straps or adhesive tape!
- Make sure the cables are not subjected to pulling, pressing or shearing forces!
- If the cables are run through drilled holes, protect the cables by means of rubber sleeves or similar parts.

1.3.3 Assembly



- Before assembly, an equalization of potential between the assembly worker and the module must be effected in order to prevent a destruction by a discharge of static electricity.

Technical Product Manual

VDO cockpit vision VDO cockpit international

2. Electronic Speedometer (dia. 80 mm/dia. 100 mm)

Contents	Page
2.1 General informations	2 - 2
2.2 Technical data	2 - 4
2.3 Speed sensor	2 - 8
2.4 Wiring diagrams	2 - 9
2.5 Setting	2 - 11
2.6 Operation	2 - 16
2.7 Speed display	2 - 17
2.8 Testing instructions	2 - 18
2.9 Instruments survey	2 - 21

Installation instructions

999-165-001: VDO cockpit international
999-165-002: VDO cockpit vision

See file 'Installation Instructions (MA)'.

Operating instructions (copy)

See enclosures TU00-0777-0010502 page 1 and 2.

Technical Product Manual

VDO cockpit vision VDO cockpit international

2. Electronic Speedometer (dia. 80 mm/dia. 100 mm)

2.1 General Informations

The electronic speedometer has been designed for land-bound vehicles only (with the exception of motorcycles).

The instrument has an analog speed display, and a liquid crystal display for the distance (displaying total distance or partial distance alternatively).

Hall sensors, inductive sensors or blocking oscillator sensors can be used as speed sensors.

A pushbutton in the front lens is provided for setting and operation of the instrument.



The electronic speedometer should be installed by a Mannesmann VDO Kienzle workshop or an authorized specialised workshop.



The lamp sockets are clipped in. To replace the light bulb, carefully, with the thumb, push the lamp holder out to the side.

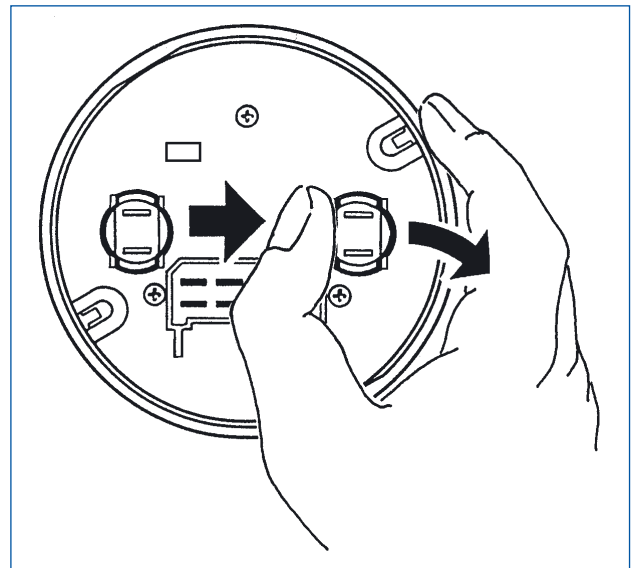

Technical Product Manual

VDO cockpit vision VDO cockpit international

2. Electronic Speedometer (dia. 80 mm/dia. 100 mm)

2.1 General Informations

Designation of function

Stepper motor movement

The drive for this display system is a stepper motor, comprising a permanent magnet rotor within a crossed winding arrangement. A zero backlash gearbox at the output ensures a high drive torque and fine resolution. The gearbox has a reduction ratio of 43.2 : 1 and an internal mechanical stop. The stepper motor drive was developed specially by VDO for this product.

The drive produces a bipolar sinusoidal variable voltage using digital pulse width modulation. There is a 90° phase difference (sine-cosine) between the voltages on the two motor coils. This rotates the electromagnetic field through equidistant angular steps with a constant length resultant vector ($\sin^2\theta + \cos^2\theta = 1$).

The motor torque is therefore constant at each step with zero cogging. At the pointer one motor step equals 0.065°.

The stepper motor parameters and the design of VDO control-driver electronics are carefully matched to ensure reliable operation of the system under all conditions. Optimised control algorithms ensure a visually smooth pointer motion.

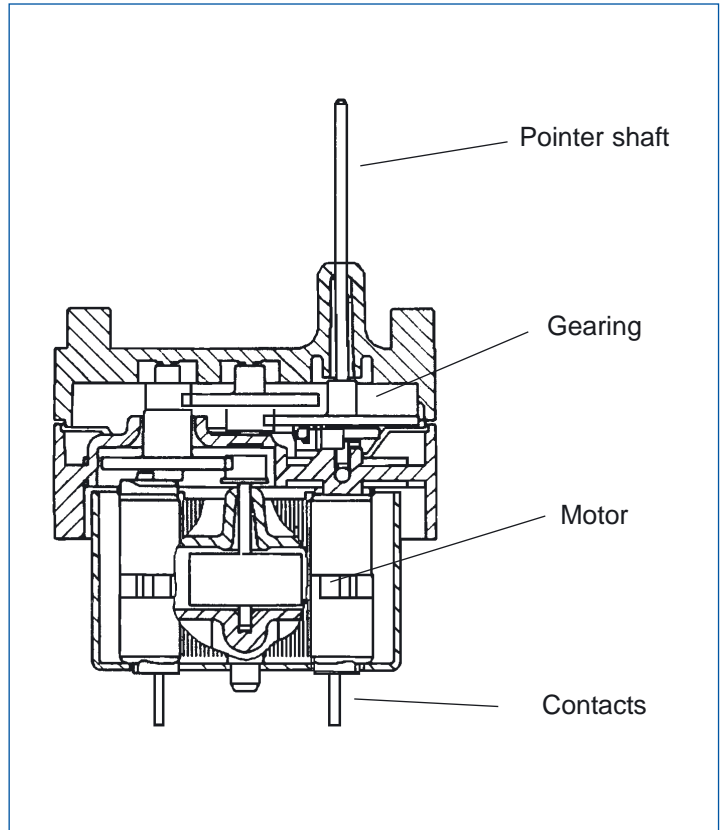

Technical Product Manual

VDO cockpit vision VDO cockpit international

2. Electronic Speedometer (dia. 80 mm/dia. 100 mm)

2.2 Technical Data

Operating voltage:	10 ... 31 V
Input voltage:	U_{low} : 0 V U_{high} : min. 1 V
Movement:	stepper motor
Pickup:	hall sensor or inductive sensor or blocking oscillator sensor or speed signal from electronics
Current consumption:	< 100 mA (120 mA with illumination)
Operating temp.:	-20°C ... +70°C
Storage temperature:	-30°C ... +85°C
Illumination:	2 light bulbs 12 V, 2 W 4 colour caps (2 green and 2 red)
Protection:	IP64 DIN 40050 from the front, housing "ozon"-proof, "UV"-proof, CE approved, reverse-polarity protection
EMC test:	according to EN 13309 and ISO 13766
Vibration resistance:	max. 1g eff., 25 ... 500 Hz, duration 8h, f: 1 octave/min.
Nominal position:	NL 0 to NL 90, DIN 16257

VDO cockpit vision
Ø 80 mm Backlight

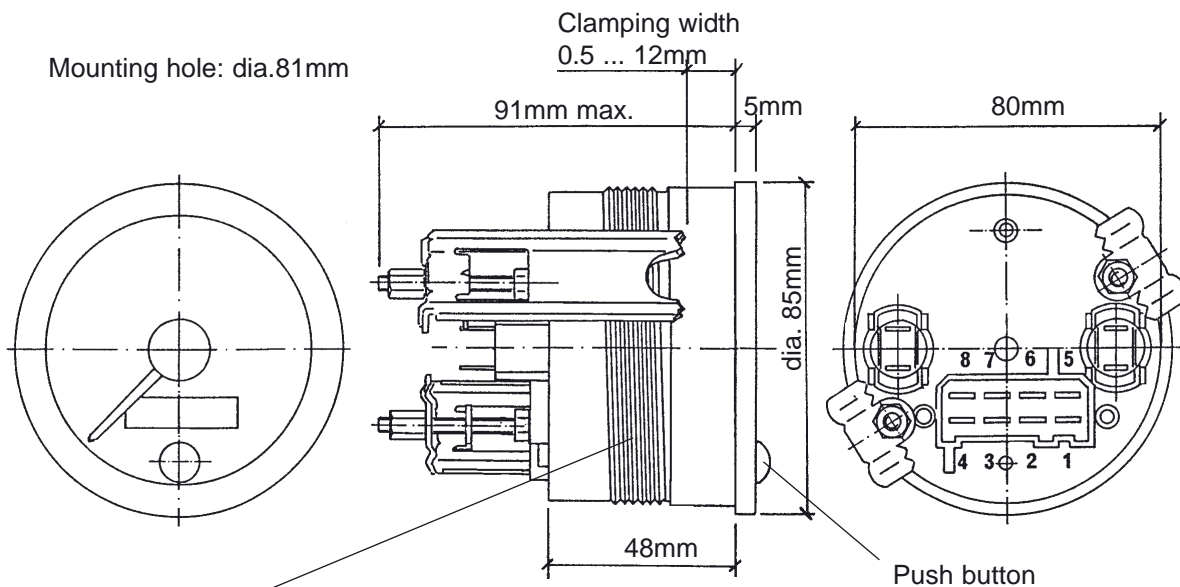

Thread for clamp ring
(clamping width 0.5 ... 12mm
or 12 ... 23mm)

Ratio
500 ... 399990 pulses/km or mile
(adjustable)

Pin assignment:
Pin 2: + 12 V for sensor
Pin 3: Ground (terminal 31)
Pin 4: + 10 ... + 31 V (terminal 15)
Pin 6: + 12 V for open collector sensor
Pin 7: Ground for 2-pole sensor wire
Pin 8: Input sensor signal

Technical Product Manual

VDO cockpit vision VDO cockpit international

2. Electronic Speedometer (dia. 80 mm/dia. 100 mm)

2.2 Technical Data

Operating voltage:	10 ... 31 V
Input voltage:	U_{low} : 0 V U_{high} : min. 1 V
Movement:	stepper motor
Pickup:	hall sensor or inductive sensor or blocking oscillator sensor or speed signal from electronics
Current consumption:	< 100 mA (120 mA with illumination)
Operating temp.:	-20°C ... +70°C
Storage temperature:	-30°C ... +85°C
Illumination:	2 light bulbs 12 V, 2 W 4 colour caps, 2 green and 2 red
Protection:	IP64 DIN 40050 from the front, housing "ozon"-proof, "UV"-proof, CE approved, reverse-polarity protection
EMC test:	according to EN 13309 and ISO 13766
Vibration resistance:	max. 1g eff., 25 ... 500 Hz, duration 8h, f: 1 octave/min.
Nominal position:	NL 0 to NL 90, DIN 16257

VDO cockpit vision
Ø 100 mm Backlight

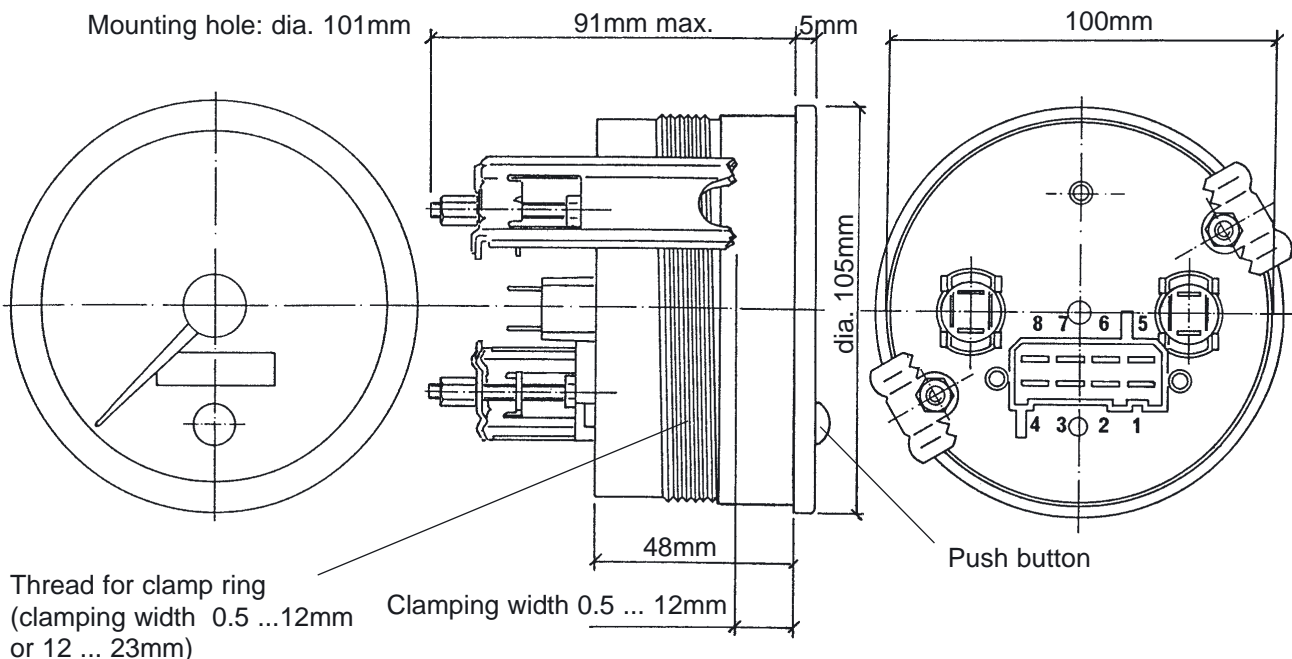

Ratio
500 ... 399990 pulses/km or mile
(adjustable)

Pin assignment:
Pin 2: + 12 V for sensor
Pin 3: Ground (terminal 31)
Pin 4: + 10 ... + 31 V (terminal 15)
Pin 6: + 12 V for open collector sensor
Pin 7: Ground for 2-pole sensor wire
Pin 8: Input sensor signal

Technical Product Manual

VDO cockpit vision VDO cockpit international

2. Electronic Speedometer (dia. 80 mm/dia. 100 mm)

2.2 Technical Data

Operating voltage:	10 ... 31 V
Input voltage:	U_{low} : 0 V U_{high} : min. 1 V
Movement:	stepper motor
Pickup:	hall sensor or inductive sensor or blocking oscillator sensor or speed signal from electronics
Current consumption:	< 100 mA (120 mA with illumination)
Operating temp.:	-20°C ... +70°C
Storage temperature:	-30°C ... +85°C
Illumination:	2 light bulbs 12 V, 2 W
Protection:	IP64 DIN 40050 from the front, housing "ozon"-proof, "UV"-proof, CE approved, reverse-polarity protection
EMC test:	according to EN 13309 and ISO 13766
Vibration resistance:	max. 1g eff., 25 ... 500 Hz, duration 8h, f: 1 octave/min.
Nominal position:	NL 0 to NL 90, DIN 16257

VDO cockpit international
Ø 80 mm Floodlight



Mounting hole: dia. 81mm

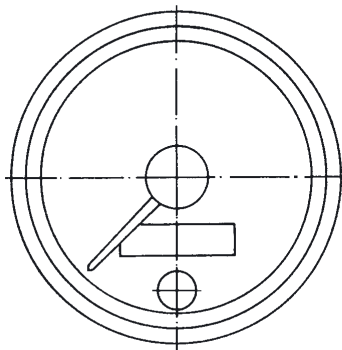

Clamping width
0.5 ... 12mm

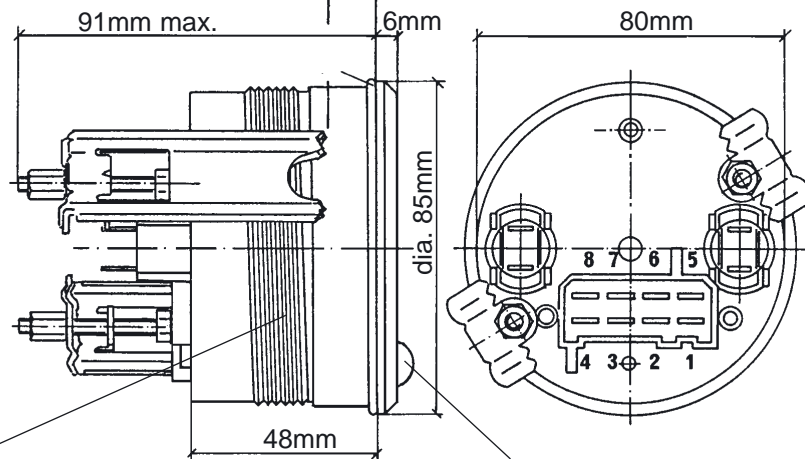

Thread for clamp ring
(clamping width 0.5 ... 12mm
or 12 ... 23mm)

Push button

Ratio
500 ... 399990 pulses/km or mile
(adjustable)

Pin assignment:
Pin 2: + 12 V for sensor
Pin 3: Ground (terminal 31)
Pin 4: + 10 ... + 31 V (terminal 15)
Pin 6: + 12 V for open collector sensor
Pin 7: Ground for 2-pole sensor wire
Pin 8: Input sensor signal

Technical Product Manual

VDO cockpit vision VDO cockpit international

2. Electronic Speedometer (dia. 80 mm/dia. 100 mm)

2.2 Technical Data

Operating voltage:	10 ... 31 V
Input voltage:	U_{low} : 0 V
	U_{high} : min. 1 V
Movement:	stepper motor
Pickup:	hall sensor or
	inductive sensor or
	blocking oscillator sensor or
	speed signal from electronics
Current consumption:	< 100 mA (120 mA with illumination)
Operating temp.:	-20°C ... +70°C
Storage temperature:	-30°C ... +85°C
Illumination:	2 light bulbs 12 V, 2 W
Protection:	IP64 DIN 40050 from the front, housing "ozon"-proof, "UV"-proof, CE approved, reverse-polarity protection
EMC test:	according to EN 13309 and ISO 13766
Vibration resistance:	max. 1g eff., 25 ... 500 Hz, duration 8h, f: 1 octave/min.
Nominal position:	NL 0 to NL 90, DIN 16257

VDO cockpit international
Ø 100 mm Floodlight

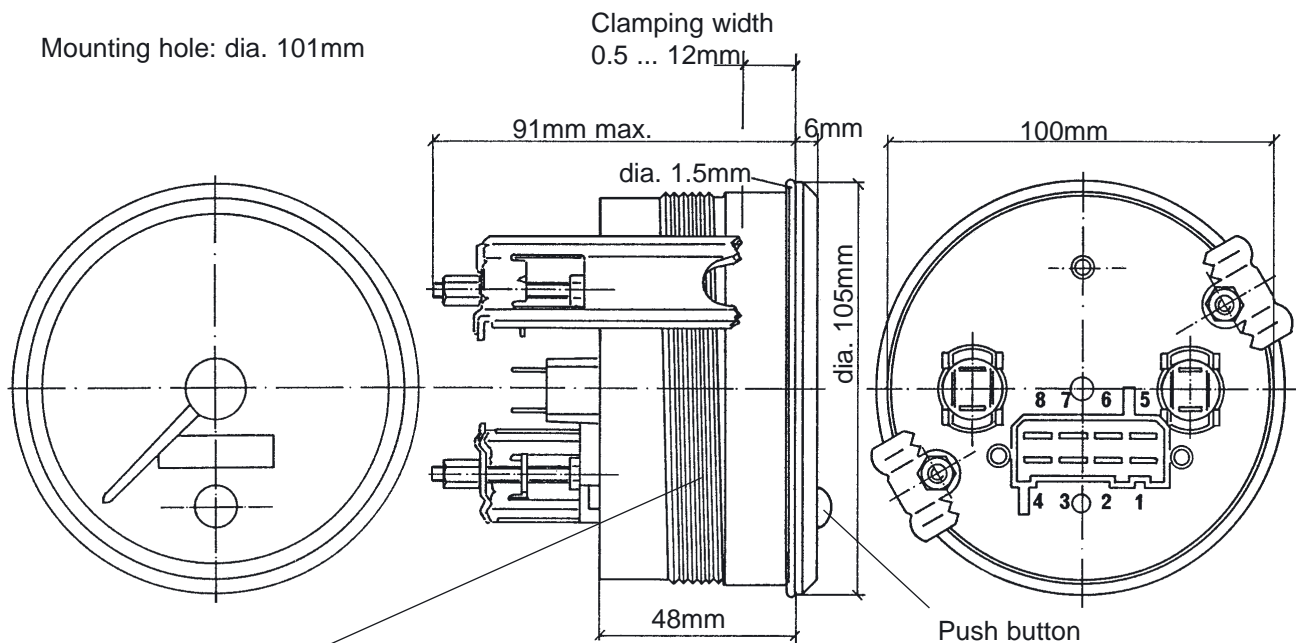

Thread for clamp ring
(clamping width 0.5 ... 12mm
or 12 ... 23mm)

Ratio
500 ... 399990 pulses/km or mile
(adjustable)

Pin assignment:
Pin 2: + 12 V for sensor
Pin 3: Ground (terminal 31)
Pin 4: + 10 ... + 31 V (terminal 15)
Pin 6: + 12 V for open collector sensor
Pin 7: Ground for 2-pole sensor wire
Pin 8: Input sensor signal

Technical Product Manual

VDO cockpit vision VDO cockpit international

2. Electronic Speedometer (dia. 80 mm/dia. 100 mm)

2.3 Speed Sensor

The speed sensor needed to operate the instrument is not included with the speedometer. The following speed sensors (see data sheets for sensors) can be used:

- **Hall sensor**

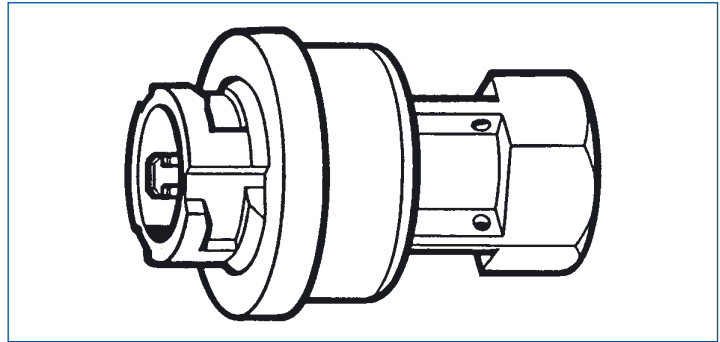

- **Inductive sensor**

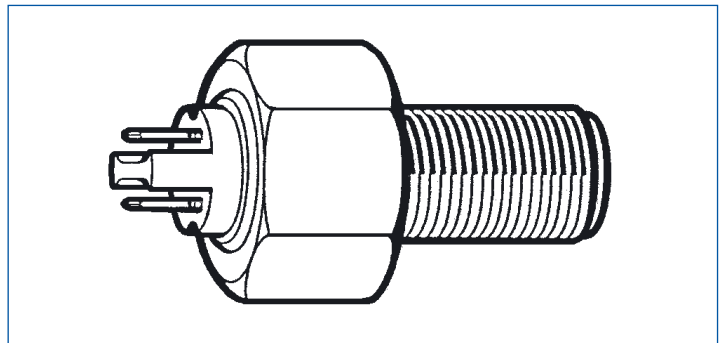

- **Blocking oscillator sensor**

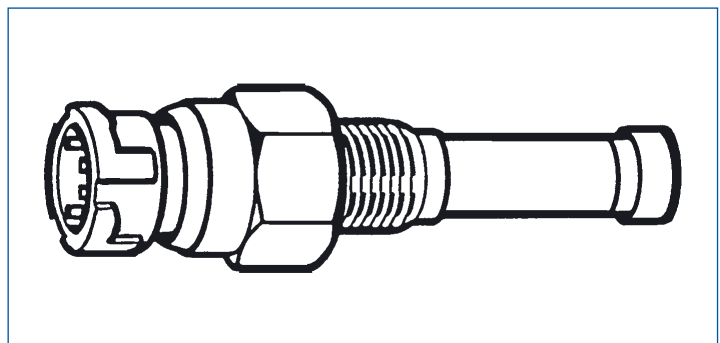

If the vehicle is already equipped with a speed sensor. Request a data sheet of this sensor. Ask your vehicle manufacturer or VDO Kienzle whether the speed sensor can be used.

Technical Product Manual

VDO cockpit vision VDO cockpit international

2. Electronic Speedometer (dia. 80 mm/dia. 100 mm)

2.4 Wiring Diagrams

Hall sensor

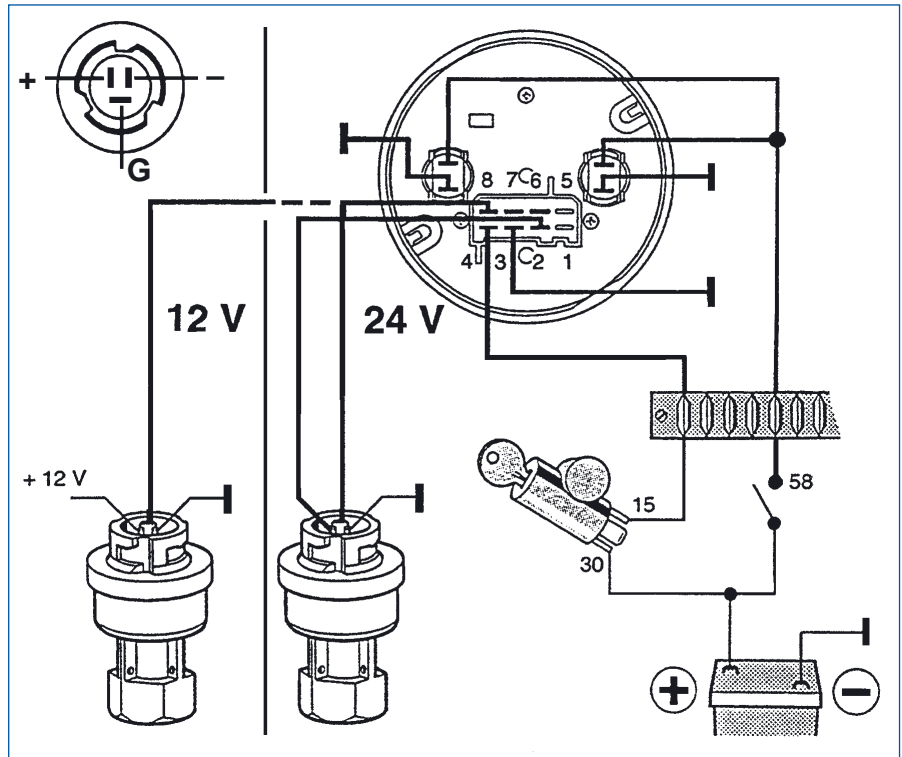

Hall sensor with 'open collector' output

Pins 6 and 8 must be bridged for hall sensors with open collector output.

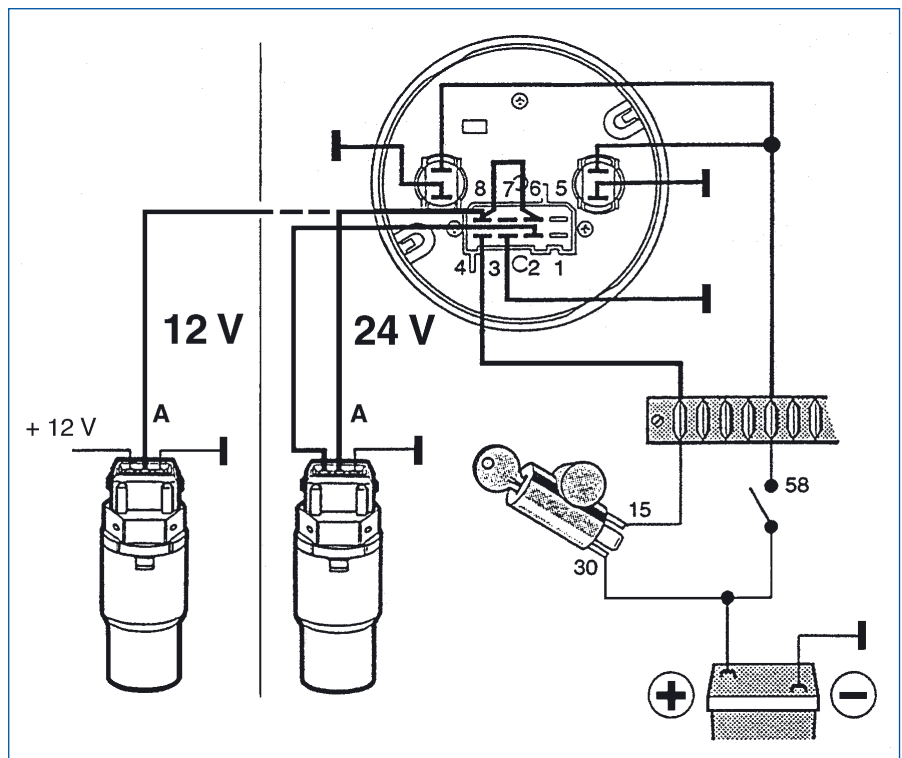

Technical Product Manual

VDO cockpit vision VDO cockpit international

2. Electronic Speedometer (dia. 80 mm/dia. 100 mm)

2.4 Wiring Diagrams

Inductive sensor

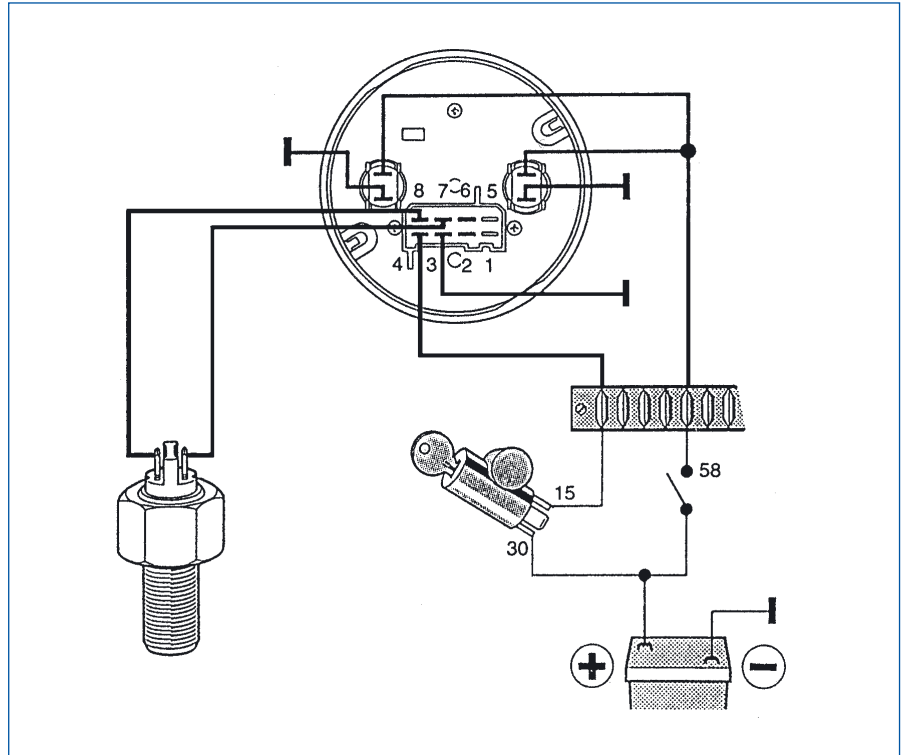

Blocking oscillator sensor

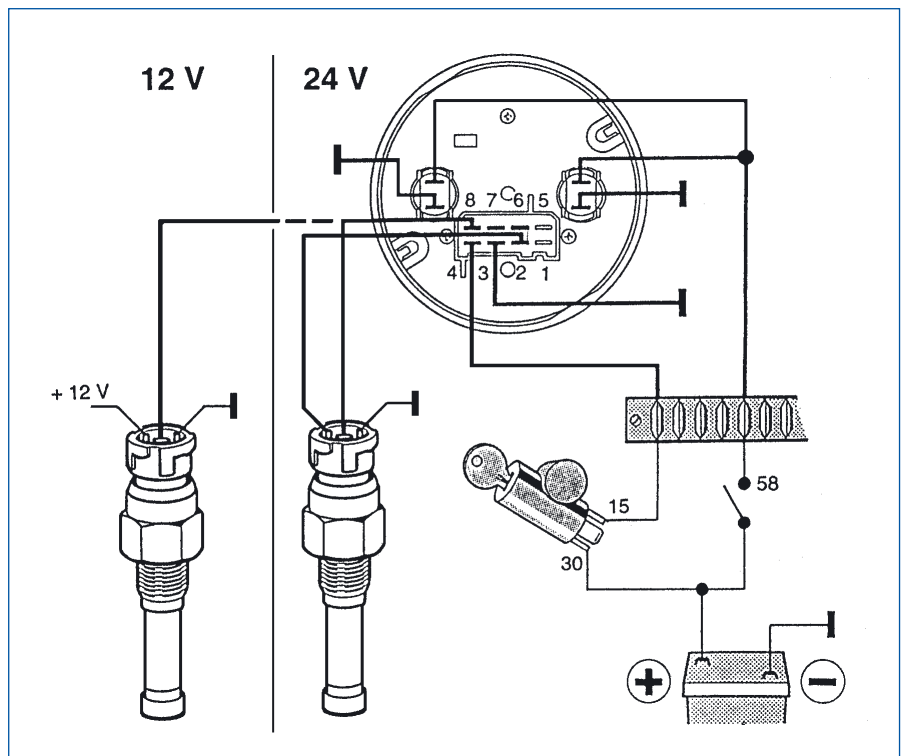

Technical Product Manual

VDO cockpit vision VDO cockpit international

2. Electronic Speedometer (dia. 80 mm/dia. 100 mm)

2.5 Setting

3 alternatives can be used for setting the instrument:

2 options for pulse/distance ratio setting:

Function "AUtOCL" - automatic calibration by driving a measured distance (1 km or 1 mile).

Function "PULSE" - enter a known pulse/distance ratio.

1 possibility for fine adjustment of the speed indication:

Function "AdJUST" - Calibration using a reference speed indication (roller test bench).

Note: Respect the tolerances per directive 75/443/EEC when calibrating the speed indication.

1. The vehicle is tested at the following speeds: 40 km/h, 80 km/h and 120 km/h or 80 % of the maximum speed specified by the manufacturer if it is lower than 150 km/h.
2. The error limit of the instrument used for the measurement of the effective vehicle speed shall not exceed $\pm 1 \%$.
3. If a measuring track is used, it shall be level and dry, and have a sufficiently non-skid surface.
4. The displayed speed shall never be lower than the effective speed. At the speed specified under 4. and at the intermediate values the difference of speed V1 displayed by the speedometer and effective speed V2 shall have the following equation:

$$0 \leq V_1 - V_2 \leq \frac{V_2}{10} + 4 \text{ km/h.}$$

Or see your national laws (directives).

Technical Product Manual

VDO cockpit vision VDO cockpit international

2. Electronic Speedometer (dia. 80 mm/dia. 100 mm)

2.5 Setting

Selection of the functions

Push button in front lens and hold in. Switch the ignition (operating voltage) on. The display alternates between 'AUtOCL', 'PULSE' and 'AdJUST' at 2 seconds interval. Select a function by releasing the pushbutton when this function is displayed.

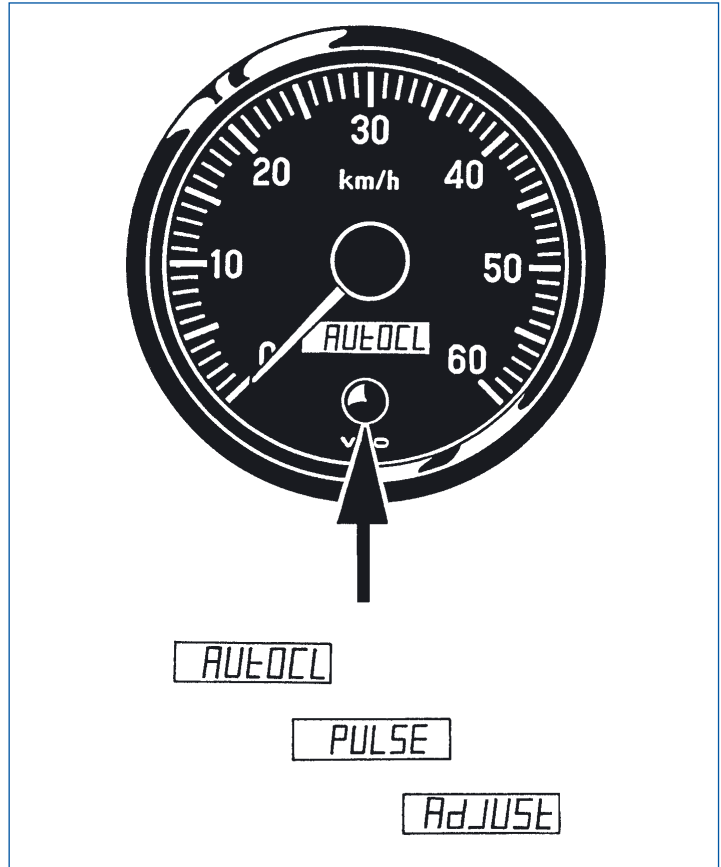

Technical Product Manual

VDO cockpit vision VDO cockpit international

2. Electronic Speedometer (dia. 80 mm/dia. 100 mm)

2.5 Setting

Function 'AUtOCL'

After selection of the function 'AUtOCL' the display changes to 'bUtOn' after 3 seconds:



Ask a passenger to assist with the calibration!
No speed is displayed during the measuring drive!

During the drive exactly at the beginning of the measuring track (1km or 1mile) push the button briefly, the display flashes 'StArT'. Drive the test track with as constant a speed as possible. Exactly at the end of the measuring track again briefly push the button. The determined pulse/distance ratio is displayed if it is between 500 and 399990 pulses (e.g. 'P 50000', which corresponds to pulse/distance ratio 50000). The calibration is completed if the display changes to total or partial distance display.

Repeat the calibration if the display flashes 'F00' (no pulses). The sequence is the same as described above.

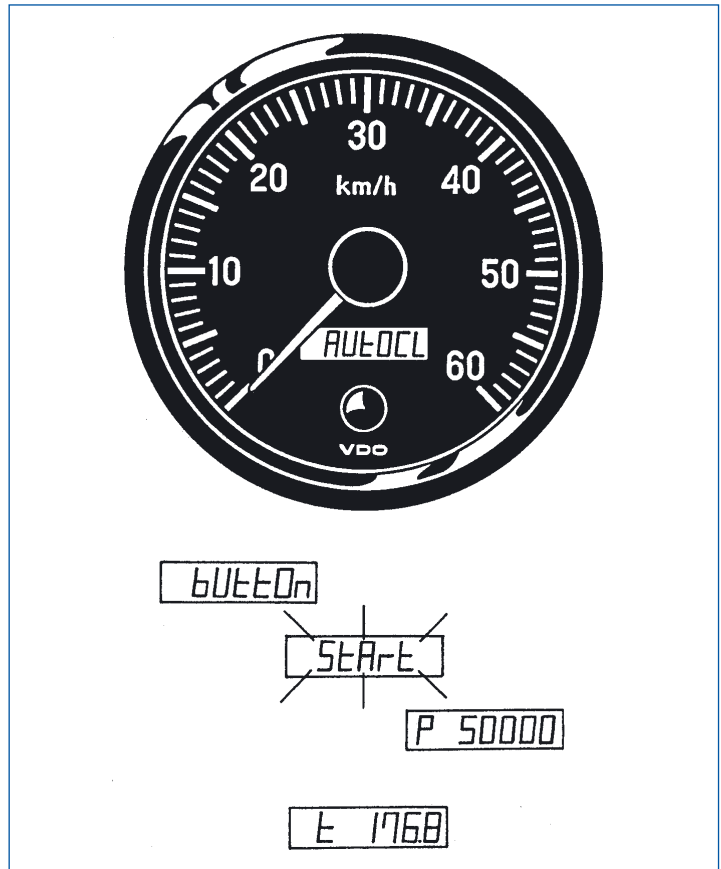

Technical Product Manual

VDO cockpit vision VDO cockpit international

2. Electronic Speedometer (dia. 80 mm/dia. 100 mm)

2.5 Setting

Function 'PULSE'

After selection of the function 'PULSE' the display shows 'P 50000', for instance, after 3 seconds, with the digit before the last one flashing start entering the pulse/distance ratio immediately. The flashing digit is changed by pushing the button (adjustable pulse/distance ratio 500 to 399990). After entry of the pulse/distance ratio the display changes to total or partial distance display, the calibration is completed.

A new setting is required if the digit before the last one is flashing in the display after pulse/distance ratio setting. The sequence is the same as described above.

The function 'PULSE' can be used to check the pulse/distance ratio stored by automatic calibration (function 'AUtOCL'). The stored pulse/distance ratio is displayed (e.g. 'P 50000'), and the digits start flashing, beginning with the digit before the last one.

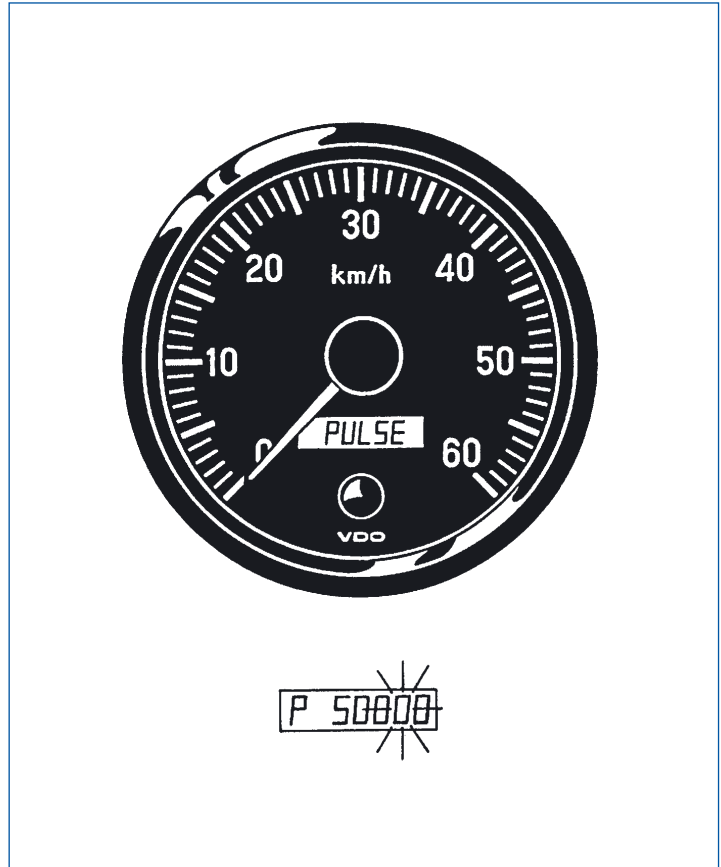

Technical Product Manual

VDO cockpit vision VDO cockpit international

2. Electronic Speedometer (dia. 80 mm/dia. 100 mm)

2.5 Setting

Function 'AdJUST'

After selection of the function 'AdJUST' the display alternates between 'UP' and 'dn' (down) after 3 seconds.



Only use this function on the roller test bench!

The fine adjustment is only possible between 30 % and 100 % of the indicating range. No pulse/distance ratio counting takes place during fine adjustment.

Pushing and holding the button when 'UP' is displayed increases the pointer indication ('dn' will lower it accordingly). Initially the change of the indication will be very slow for a very precise adjustment. Releasing the button for a short time repeats the cycle. The rate of pointer indication change increases when the button is held for a longer time. Release the button when the pointer indication corresponds to the reference speed. After 1 minute the display shows total or partial distance. Fine adjustment has been completed.

A wrong pulse/distance ratio entry (function 'PULSE') exists if the display starts flashing during fine adjustment. The pulse/distance ratio is either below 500 or above 399990.

Repeat the calibration with the function 'PULSE'.

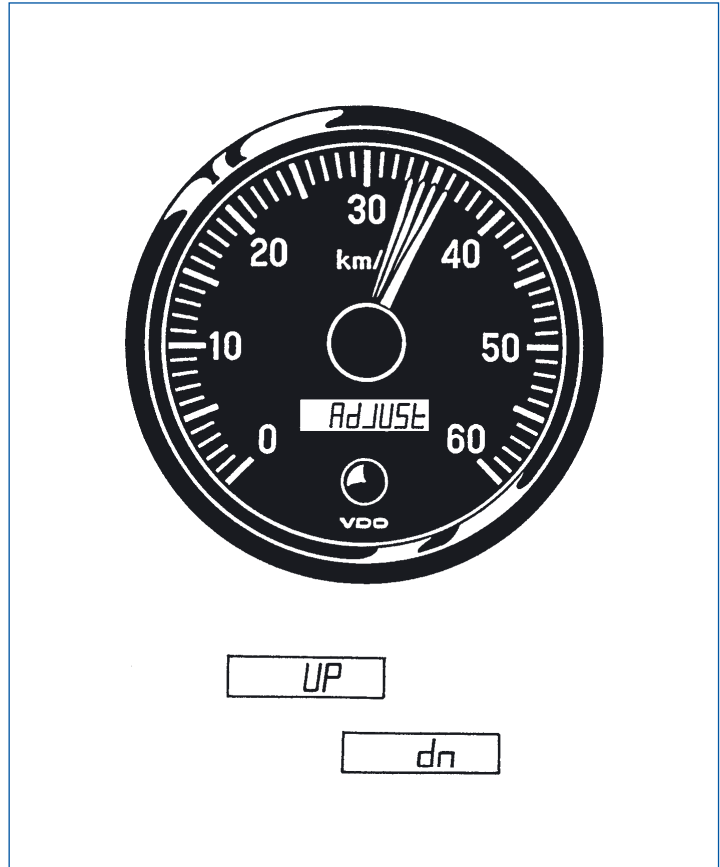

Technical Product Manual

VDO cockpit vision VDO cockpit international

2. Electronic Speedometer (dia. 80 mm/dia. 100 mm)

2.6 Operation

Only efficient when ignition is switched on.

Briefly pushing the button alternates the total distance display (e.g. '99910.9') with the partial distance display (e.g. 't 176.8').

The total distance function counts the total mileage in kilometer or miles up to 999999.9 max..
This display cannot be reset.

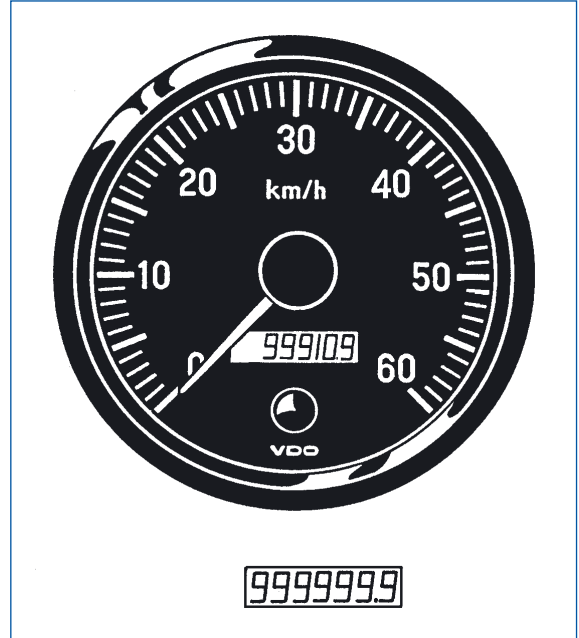

The partial distance function counts the mileage in kilometer or miles up to 't9999.9'.
This display is reset to 't0.0' by pushing the button (for 2 seconds approximately).

Pushing the button for 2 seconds when total distance is displayed will also reset the partial distance to 't0.0'.

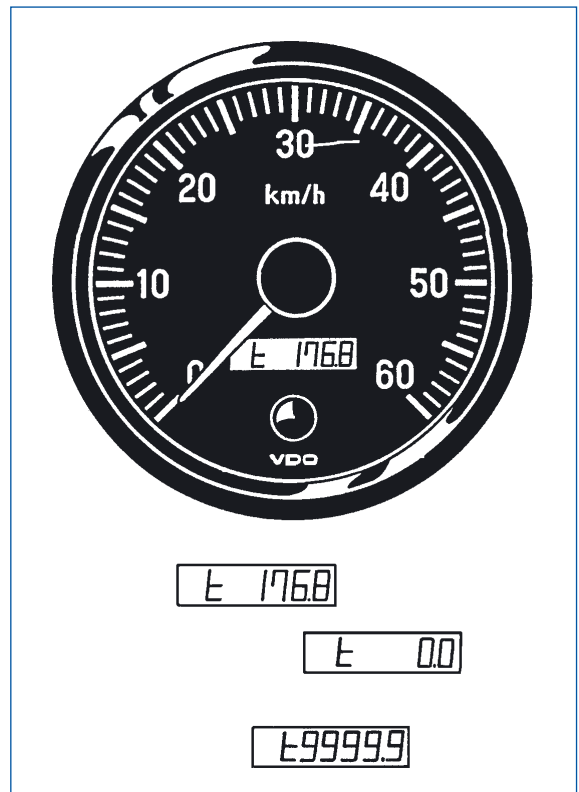

Trip and total distance remain stored after the operating voltage is switched off.

Technical Product Manual

VDO cockpit vision VDO cockpit international

2. Electronic Speedometer (dia. 80 mm/dia. 100 mm)

2.7 Speed Display

Note:



When ignition is switched off, the pointer remains at the last speed indicated, until the ignition is switched on again, without starting the engine, the pointer will then return to the zero position.



Technical Product Manual

VDO cockpit vision VDO cockpit international

2. Electronic Speedometer (dia. 80 mm/dia. 100 mm)

2.8 Testing Instruction

Test accessories

- 1x Power supply
- 1x Test cable No. 2 } contained in test cables kit
- 1x Measuring cable } X12-019-101-001
- 1x Frequency generator
- 1x Ammeter
- 1x Voltmeter

Connector pin allocation

1	2	3	4
5	6	7	8

Pin 2 + 12 V for sensor
Pin 3 Ground
Pin 4 + 10V to + 31V
Pin 6 + 12 V for open collector sensor
Pin 8 Sensor signal input

Test circuit diagram

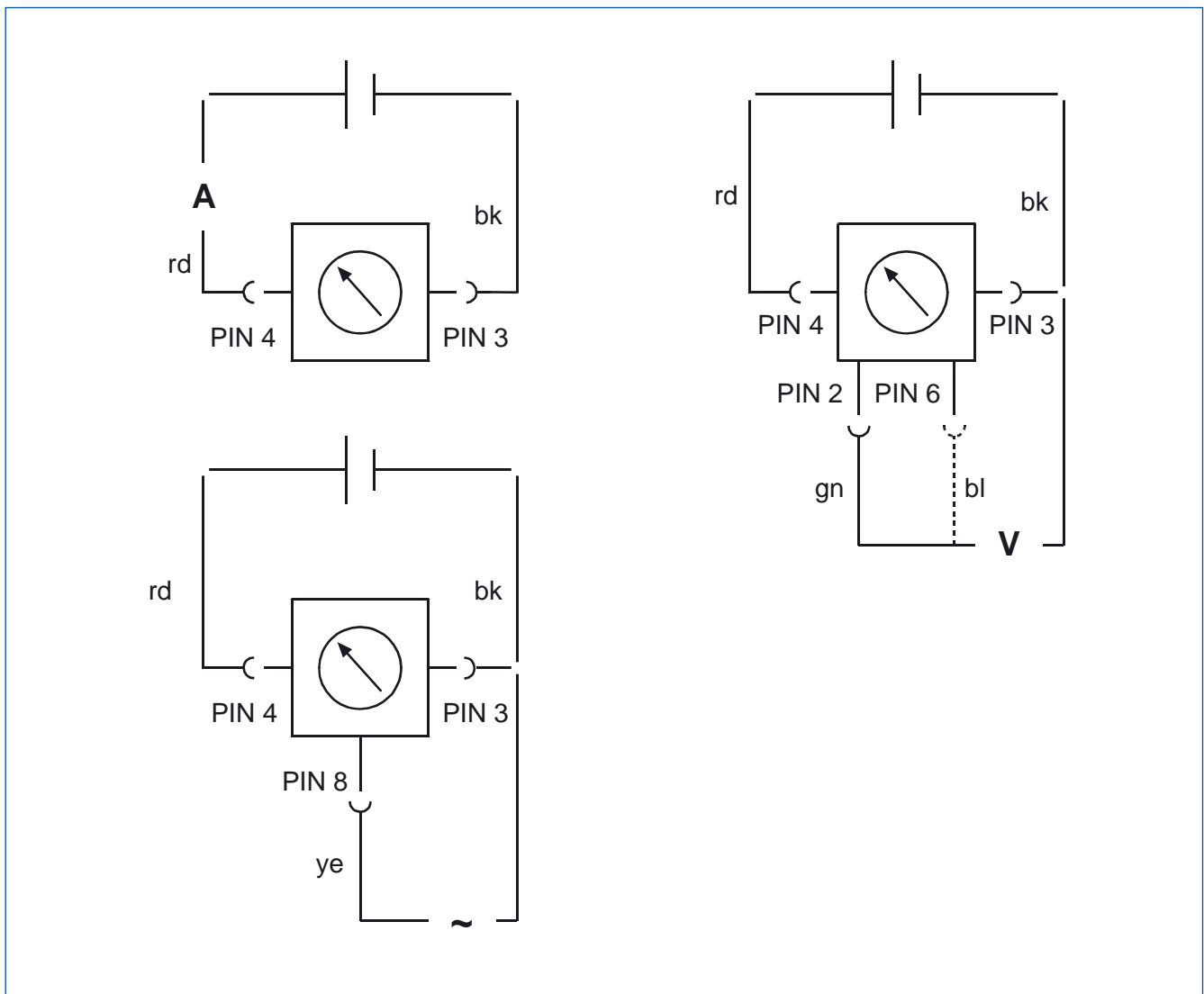

Technical Product Manual

VDO cockpit vision VDO cockpit international

2. Electronic Speedometer (dia. 80 mm/dia. 100 mm)

2.8 Testing Instruction

Test method description

Basic setting: 12V to 24V instruments  $U = 18V \pm 2V$

Measurement of current consumption

Connect instrument with test cable No. 2 as shown in test circuit diagram I.

Range of values: 12V to 24V instruments  $I = 52 \pm 5.2 \text{ mA}$

Test of outputs pin 2 and pin 6

Connect instrument with test cable No. 2 as shown in test circuit diagram II.

Range of values: 12V to 24V instruments  $U = 14.5 \pm 2 \text{ V}$

Test of distance counter

Connect instrument with test cable No. 2 as shown in test circuit diagram III.

Connect a square wave signal to pin 8 of the connector. The frequency depends on the maximum speed and the pulse/distance ratio. Use the formula given under 'Pointer position test', section b, for the accurate calculation of the maximum square wave frequency. The amplitude is in the range 1 to 10 V.

After connection of the operating voltage the display will show the total or the partial distance. Set the frequency generator to 0 Hz, and slowly raise the frequency until the counter starts counting (e.g. at 60 km/h, 1 minute = 1 kilometer).



It is only possible to zero the total odometer reading with the testing software (see chapter 18.2.6).

Technical Product Manual

VDO cockpit vision VDO cockpit international

2. Electronic Speedometer (dia. 80 mm/dia. 100 mm)

2.8 Testing Instructions

Pointer position test

a) Zero point test

Connect instrument with test cable No.2 as shown in test circuit diagram III.
Connect the operating voltage and check pointer deviation. The allowed deviation is ± 1 degree of angle.

b) Full scale indication test

Connect instrument with test cable No.2 as shown in test circuit diagram III.

$$f_{\max} = \frac{\text{speed} \times \text{pulse/distance ratio (K)}}{3600} \text{ [Hz]}$$

c) Speed indication test

At 40 km/h, 80 km/h and 120 km/h or 80% of full scale if it is lower than 150 km/h.
Connect instrument with test cable No. 2 as shown in test circuit diagram III.

$$f_{\max} = \frac{\text{speed} \times \text{pulse/distance ratio (K)}}{3600} \text{ [Hz]}$$

Note:



Respect the tolerances per directive 75/443/EEC or your national laws (directives) when testing the speed indication.

The directive 75/443/EEC says that the following relation must exist between the displayed (per speedometer) and the effective speed (per test fixture):

v_1 = displayed speed v_2 = effective speed

$$0 \leq v_1 - v_2 \leq \frac{v_2}{10} + 4 \text{ km/h.}$$

Example:

Speedometer, full scale 300 km/h, pulse/distance ratio (K) = 6000 pulses/km

$$f_{\max} = \frac{\text{speed} \times \text{pulse/distance (K)}}{3600} \text{ [Hz]}$$

The maximum tolerance of this speedometer (at 500 Hz = full scale) is:

$$[v_1 - 300 \leq \frac{300}{10} + 4 \text{ km/h}] = [v_1 - 300 \leq + 34 \text{ km/h}]$$

Technical Product Manual

VDO cockpit vision VDO cockpit international

2. Electronic Speedometer (dia. 80 mm/dia. 100 mm)

2.9 Instruments Survey

VDO cockpit vision (Backlight) dia. 80 mm / dia. 100 mm

Part No. 437-015-...

Dial		Special feature	Part No.
Range	Imprint		
0 ... 200 km/h	km/h	dia. 80 mm, 12 - 24 V 12 V illumination	001K
0 ... 300 km/h	km/h	dia. 80 mm, 12 - 24 V 12 V illumination	002K
▲ 0 ... 140 mph / 220 km/h	MPH, km/h	dia. 80 mm, 12 - 24 V ● 12 V illumination, dual scale	016C
0 ... 200 km/h	km/h	dia. 100 mm, 12 - 24 V 12 V illumination	007G
0 ... 300 km/h	km/h	dia. 100 mm, 12 - 24 V 12 V illumination	008G
▲ 0 ... 220 mph / 360 km/h	MPH, km/h	dia. 100 mm, 12 - 24 V 12 V illumination, dual scale	009G
▲ 0 ... 140 mph / 220 km/h	MPH, km/h	dia. 100 mm, 12 - 24 V ● 12 V illumination, dual scale	017C
▲ range stated first is outer range			
● with clamp ring instead of stud bolts and brackets			

Technical Product Manual

VDO cockpit vision VDO cockpit international

2. Electronic Speedometer (dia. 80 mm/dia. 100 mm)

2.9 Instruments Survey

VDO cockpit international (Floodlight) dia. 80 mm

Part No. 437-035-...

Dial		Special feature	Part No.
Range	Imprint		
0 ... 60 km/h	km/h	dia. 80 mm, 12 - 24 V 12 V illumination	001C 001G
0 ... 120 km/h	km/h	dia. 80 mm, 12 - 24 V 12 V illumination	002C * 002G
0 ... 200 km/h	km/h	dia. 80 mm, 12 - 24 V 12 V illumination	003C * 003G
0 ... 80 km/h	km/h	dia. 80 mm, 12 - 24 V 12 V illumination	012C
▲ 0 ... 50 mph / 80 km/h	MPH, km/h	dia. 80 mm, 12 - 24 V ● 12 V illumination, dual scale	013C *
▲ 0 ... 85 mph / 135 km/h	MPH, km/h	dia. 80 mm, 12 - 24 V ● 12 V illumination, dual scale	014C
▲ 0 ... 120 mph / 190 km/h	MPH, km/h	dia. 80 mm, 12 - 24 V ● 12 V illuminatio, dual scale	015C
▲ 0 ... 50 km/h / 30 mph	km/h, MPH	dia. 80 mm, 12 - 24 V ● 12 V illumination, dual scale	017C
▲ range stated first is outer range			
● with clamp ring instead of stud bolts and brackets * phase-out			

Technical Product Manual

VDO cockpit vision VDO cockpit international

2. Electronic Speedometer (dia. 80 mm/dia. 100 mm)

2.9 Instruments Survey

VDO cockpit international (Floodlight) dia. 100 mm

Part No. 437-035-...

Dial		Special feature	Part No.
Range	Imprint		
0 ... 120 km/h	km/h	dia. 100 mm, 12 - 24 V 12 V illumination ▼	011C

▼ with profile rubber ring instead of stud bolts and brackets

VDO cockpit international (Floodlight) dia. 100 mm

Part No. 437-055-...

Dial		Special feature	Part No.
Range	Imprint		
0 ... 60 km/h	km/h	dia.100 mm, 12 - 24 V 12 V illumination	001C * 001G
0 ... 120 km/h	km/h	dia.100 mm, 12 - 24 V 12 V illumination	002C 002G
▲ 0 ... 50 mph / 80 km/h	MPH, km/h	dia.100 mm, 12 - 24 V 12 V illumination, dual scale ●	004C
▲ 2 ... 85 mph / 135 km/h	MPH, km/h	dia.100 mm, 12 - 24 V 12 V illumination, dual scale ●	005C
▲ 0 ... 120 mph / 190 km/h	MPH, km/h	dia.100 mm, 12 - 24 V 12 V illumination, dual scale ●	006C
0 ... 80 km/h	km/h	dia.100 mm, 12 - 24 V 12 V illumination	009C
▲ range stated first is outer range			
● with clamp ring instead of stud bolts and brackets * phase-out			

VDO cockpit vision, VDO cockpit international, VDO modulcockpit II

Operating Instructions For Electronic Speedometer

1. Setting

3 alternatives can be used for setting the instrument:

2 options for pulse/distance ratio setting:

Function **'AUtOCL'** - automatic calibration by driving a measured distance (1 km or 1 mile)

Function **'PULSE'** - enter a known pulse/distance ratio

1 possibility for fine adjustment of the speed indication:

Function **'AdJUSt'** - calibration using a reference speed indication (roller test bench)

Note: Respect the tolerances per directive 75/443/EEC when calibrating the speed indication. A reference to them is made in § 57 StVZO, chapter 4, requirements, states:

4.3.5 The vehicle is tested at the following speeds: 40 km/h, 80 km/h and 120 km/h or 80% of the maximum speed specified by the manufacturer if it is lower than 150 km/h.

4.3.6 The error limit of the instrument used for the measurement of the effective vehicle speed shall not exceed $\pm 1\%$.

4.3.6.1 If a measuring track is used, it shall be level and dry, and have a sufficiently non-skid surface.

4.4 The displayed speed shall never be lower than the effective speed. At the speed specified under 4.3.5. and at the intermediate values the difference of speed V1 displayed by the speedometer and effective speed V2 shall have the following equation:

$$0 \leq V1 - V2 \leq \frac{V2}{10} + 4 \text{ km/h}$$

1.1 Selection Of The Functions

Push button in front lens and hold in. Switch the ignition (operating voltage) on. The display alternates between 'AUtOCL', 'PULSE' and 'AdJUSt' at 2 seconds interval. Select a function by releasing the push button when this function is displayed.



1.2 Function 'AUtOCL'

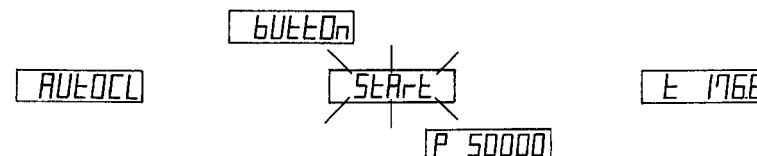

After selection of the function **'AUtOCL'** the display changes to 'bUtOn' after 3 seconds:



Ask a passenger to assist with the calibration!
No speed is displayed during the measuring drive!

During the drive exactly at the beginning of the measuring track (1 km or 1 mile) push the button briefly, the display flashes 'StArT'. Drive the test track with as constant a speed as possible. Exactly at the end of the measuring track again briefly push the button. The determined pulse/distance ratio is displayed if it is between 500 and 399990 pulses (e.g. 'P 50000', which corresponds to pulse/distance ratio 50000). The calibration is completed if the display changes to total or partial distance display.

Repeat the calibration if the display flashes 'F00' (no pulses). The sequence is the same as described above.

1.3 Function 'PULSE'



After selection of the function **'PULSE'** the display shows 'P 50000', for instance, after 3 seconds, with the digit before the last one flashing start entering the pulse/distance ratio immediately. The flashing digit is changed by pushing the button (adjustable pulse/distance ratio 500 to 399990). After entry of the pulse/distance ratio the display changes to total or partial distance display, the calibration is completed.

A new setting is required if the digit before the last one is flashing in the display after pulse/distance ratio setting. The sequence is the same as described above.

The function **'PULSE'** can be used to check the pulse/distance ratio stored by automatic calibration (function **'AUtOCL'**). The stored pulse/distance ratio is displayed (e.g. 'P 50000'), and the digits start flashing, beginning with the digit before the last one.

VDO cockpit vision, VDO cockpit international, VDO modulcockpit II

Operating Instructions For Electronic Speedometer

1.4 Function 'Adjust'

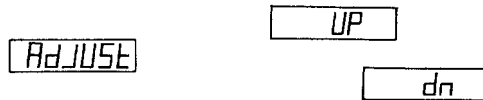

After selection of the function 'AdJUST' the display alternates between 'UP' or 'dn' (up/down) after 3 seconds.



Only use this function on the roller test bench!
The fine adjustment is only possible between 30% and 100% of the indicating range. No pulse/distance ratio counting takes place during fine adjustment.

Pushing and holding the button when 'UP' is displayed increases the pointer indication ('dn' will lower it accordingly). Initially the change of the indication will be very slow for a very precise adjustment. Releasing the button for a short time repeats the cycle. The rate of pointer indication change increases when the button is held for a longer time. Release the button when the pointer indication corresponds to the reference speed. After 1 minute the display shows total or partial distance. Fine adjustment has been completed.

A wrong pulse/distance ratio entry (function 'PULSE') exists if the display starts flashing during fine adjustment. The pulse/distance ratio is either below 500 or above 399990. Repeat the calibration with the function 'PULSE'.

2. Operation

max. 999999.9



Briefly pushing the button alternates the total distance display (e.g. '99910.9') with the partial distance display (e.g. '176.8').

The total distance function counts the total mileage in kilometers or miles up to 999999.9 max.. This display cannot be reset.

The partial distance function counts the mileage in kilometers or miles up to 't9999.9'. This display is reset to 't0.0' by pushing the button (for 2 seconds approximately).

Pushing the button for 2 seconds when total distance is displayed will also reset the partial distance to 't0.0'.

max. 999999.9

E 176.8

E 00

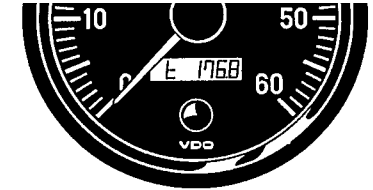

Trip and total distances remain stored after the operating voltage is switched off.

3. Speed Display

Note:



When ignition is switched off, the pointer remains at the last speed indicated, until the ignition is switched on again, without starting the engine, the pointer will then return to the zero position.

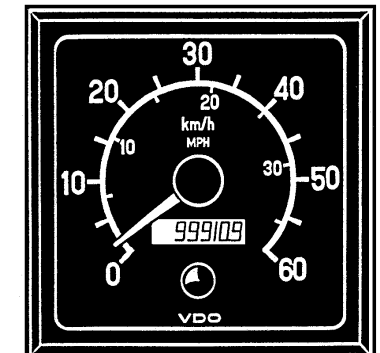

Technical Product Manual

VDO cockpit vision VDO cockpit international

3. Electronic Tachometer (dia. 80 mm / dia.100 mm)

Contents

Page

3.1	General informations	3 - 2
3.2	Technical data	3 - 4
3.3	Pulsing	3 - 8
3.4	Wiring diagram	3 - 9
3.5	Setting	3 - 10
3.6	Testing instructions	3 - 14
3.7	Instruments survey	3 - 16

Installation instructions

999-165-003: VDO cockpit international

999-165-004: VDO cockpit vision

See file 'Installation Instructions (MA)'.

Technical Product Manual

VDO cockpit vision VDO cockpit international

3. Electronic Tachometer (dia. 80 mm / dia.100 mm)

3.1 General Informations

The electronic tachometer has been designed for land-bound vehicles only (with the exception of motorcycles). The instrument has an analog engine speed display in RPM x 100.

The instrument is pulsed by terminal 1 of the ignition coil in the case of petrol engines (4, 6, 8 cylinders, four-stroke), by terminal W of the alternator in the case of diesel engines.

The instrument is set by 3 coding switches and a potentiometer at the back of the instrument.



The lamp sockets are clipped in. To replace the light bulb, carefully, with the thumb, push the lamp holder out to the side.

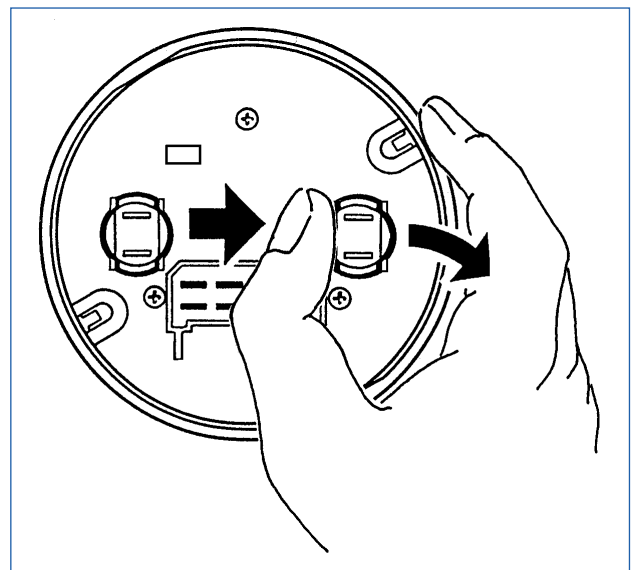

Technical Product Manual

VDO cockpit vision VDO cockpit international

3. Electronic Tachometer (dia. 80 mm / dia.100 mm)

3.1 General Informations

Designation of function

Movement: System Ke (to 320°)

(Turning magnet ratio measuring movement, pointer deflection up to 320°)

A turning magnet ratio measuring movement is the main component of the tachometer. It converts the current pulses from the sensor to an analog display on a dial. An electronic circuit converts varying current pulses to unified pulses, which are fed to the turning magnet movement. The turning magnet ratio measuring movement applies the principle of the current ratio of two separate coils. Two stationary coils generate a magnetic field as a function of the current flowing through them. The magnetic field resulting from these two fields moves a two-pole magnet disc carrying a pointer. The pointer deflection is a function of the ratio of the two currents flowing through the coils.

A shielding casing prevents the effect of external magnetic fields.

The special electronic system controlling the movement permits a pointer deflection of 320°. The rotation is limited by a pin on the turning magnet moving in a groove of the coil carrier; the opposing force is generated by a spiral spring.

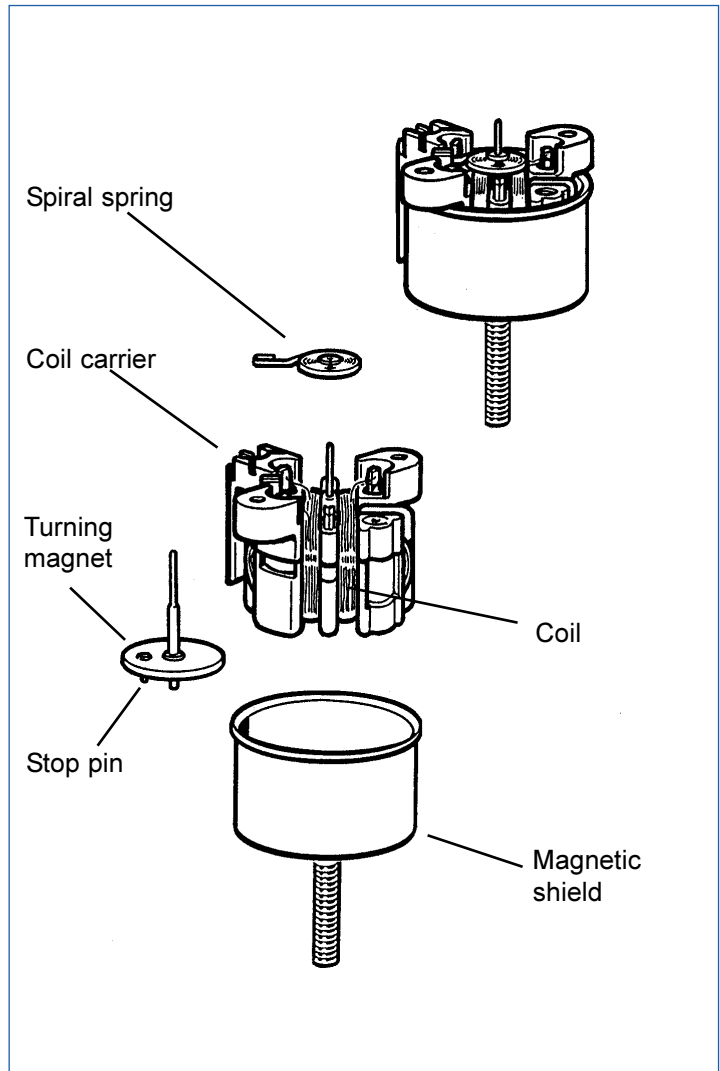

Technical Product Manual

VDO cockpit vision VDO cockpit international

3. Electronic Tachometer (dia. 80 mm / dia.100 mm)

3.2 Technical Data

Operating voltage:	10.8 ... 16 V
Input signal voltage:	U_{low} : max. 5 V U_{high} : min. 7,5 V
Movement:	System Ke (\rightarrow 320°)
Pickup:	terminal 1 ignition coil (fuel engine) terminal W alternator (diesel engine)
Current consumption:	< 100 mA (without illumination)
Operating temp.:	- 20°C ... + 70°C
Storage temperature:	- 30°C ... + 85°C
Illumination:	2 light bulbs 12 V, 2 W 4 colour caps, 2 green and 2 red
Protection:	IP64 DIN 40050 from the front housing 'ozon'-proof, 'UV'-proof CE approved, reverse-polarity protection
EMC test:	according to EN 13309 and ISO 13766
Vibration resistance:	max. 1g eff., 25 ... 500 Hz, duration 8h, f. 1 octave/min.
Nominal position:	NL 0 to NL 90, DIN 16257

VDO cockpit vision
dia. 80 mm Backlight

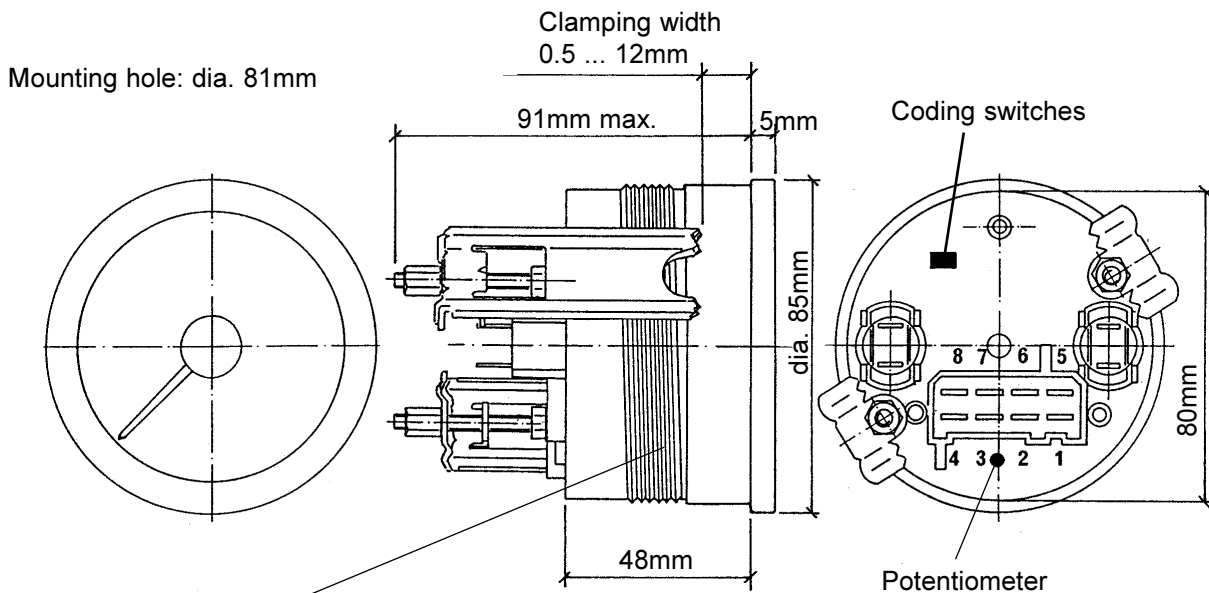
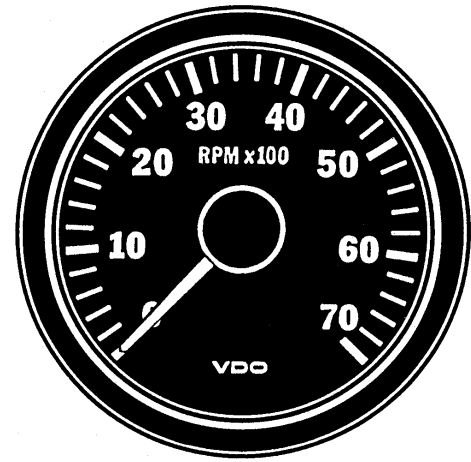

Thread for clamp ring
(Clamping width 0.5 ... 12mm
or 12 ... 23mm)

6 ... 25 pulses/revolution
(adjustable)

Pin assignment:

- Pin 1: + 24 V (for 24 V instrument)
Terminal 15
- Pin 2: + 12 V (for 12 V instrument)
Terminal 15
- Pin 3: Ground
- Pin 4: Signal input
Terminal 1 or W

Technical Product Manual

VDO cockpit vision VDO cockpit international

3. Electronic Tachometer (dia. 80 mm / dia.100 mm)

3.2 Technical Data

Operating voltage:	10.8 ... 16 V
Input signal voltage:	U_{low} : max. 5 V U_{high} : min. 7,5 V
Movement:	System Ke (\rightarrow 320°)
Pickup:	terminal 1 ignition coil (fuel engine) terminal W alternator (diesel engine)
Current consumption:	< 100 mA (without illumination)
Operating temp.:	- 20°C ... + 70°C
Storage temperature:	- 30°C ... + 85°C
Illumination:	2 light bulbs 12 V, 2 W 4 colour caps, 2 green and 2 red
Protection:	IP64 DIN 40050 from the front housing 'ozon'-proof, 'UV'-proof CE approved, reverse-polarity protection
EMC test:	according to EN 13309 and ISO 13766
Vibration resistance:	max. 1g eff., 25 ... 500 Hz, duration 8h, f: 1 octave/min.
Nominal position:	NL 0 to NL 90, DIN 16257

VDO cockpit vision
dia. 100 mm Backlight

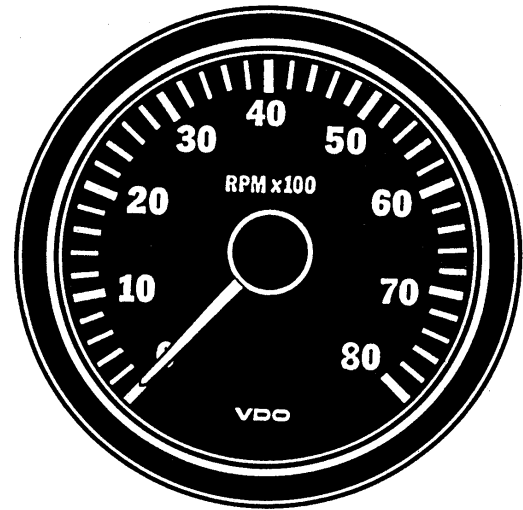

Mounting hole: dia. 101mm

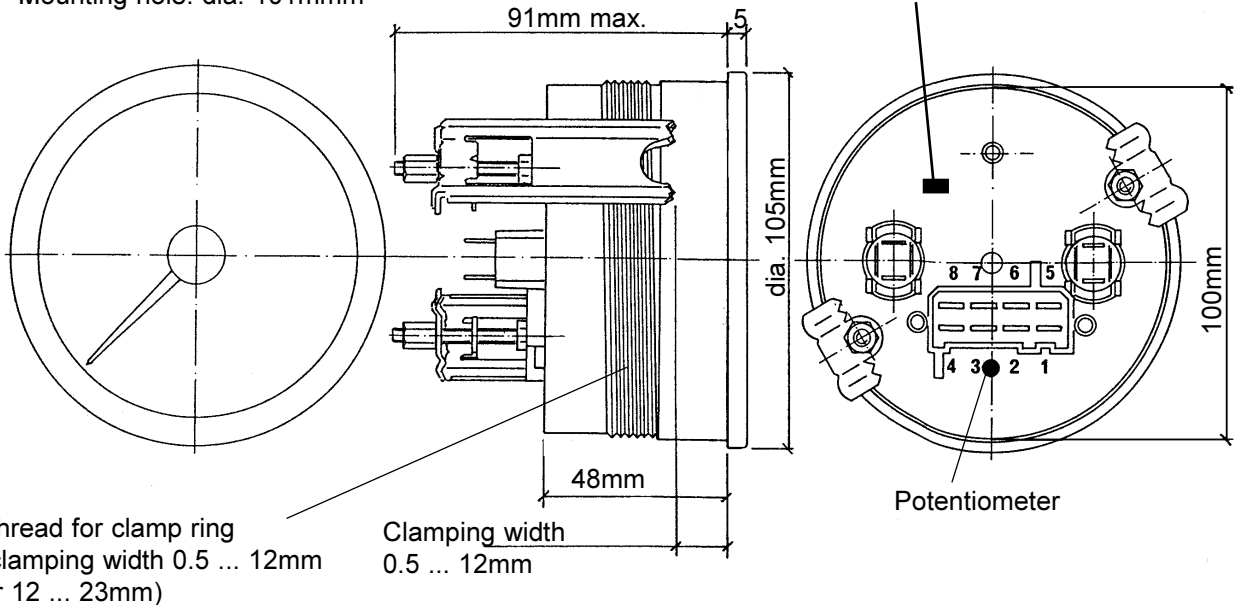

Thread for clamp ring
(clamping width 0.5 ... 12mm
or 12 ... 23mm)

Clamping width
0.5 ... 12mm

6 ... 25 pulses/revolution
(adjustable)

Pin assignment:

- Pin 1: + 24 V (for 24 V instrument)
Terminal 15
- Pin 2: + 12 V (for 12 V instrument)
Terminal 15
- Pin 3: Ground
- Pin 4: Signal input
Terminal 1 or W

Technical Product Manual

VDO cockpit vision VDO cockpit international

3. Electronic Tachometer (dia. 80 mm / dia.100 mm)

3.2 Technical Data

Operating voltage:	10.8 ... 16 V or 21 ... 32 V
Input signal voltage:	U_{low} : max. 5 V U_{high} : min. 7,5 V
Movement:	System Ke (\rightarrow 320°)
Pickup:	terminal 1 ignition coil (fuel engine) terminal W alternator (diesel engine)
Current consumption:	< 100 mA (without illumination)
Operating temp.:	- 20°C ... + 70°C
Storage temperature:	+ 30°C ... + 85°C
Illumination:	2 light bulbs 12 V, 2 W or 24 V, 2 W
Protection:	IP64 DIN 40050 from the front housing 'ozon'-proof, 'UV'-proof CE approved, reverse-polarity protection
EMC test:	according to EN 13309 and ISO 13766
Vibration resistance:	max. 1g eff., 25 ... 500 Hz, duration 8h, f: 1 octave/min.
Nominal position:	NL 0 to NL 90, DIN16 257

VDO cockpit international
dia. 80 mm Floodlight

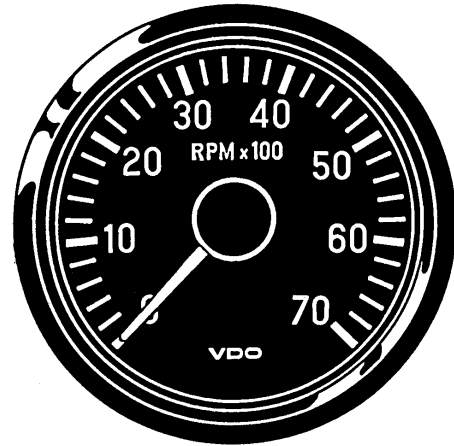

Mounting hole: dia. 81mm

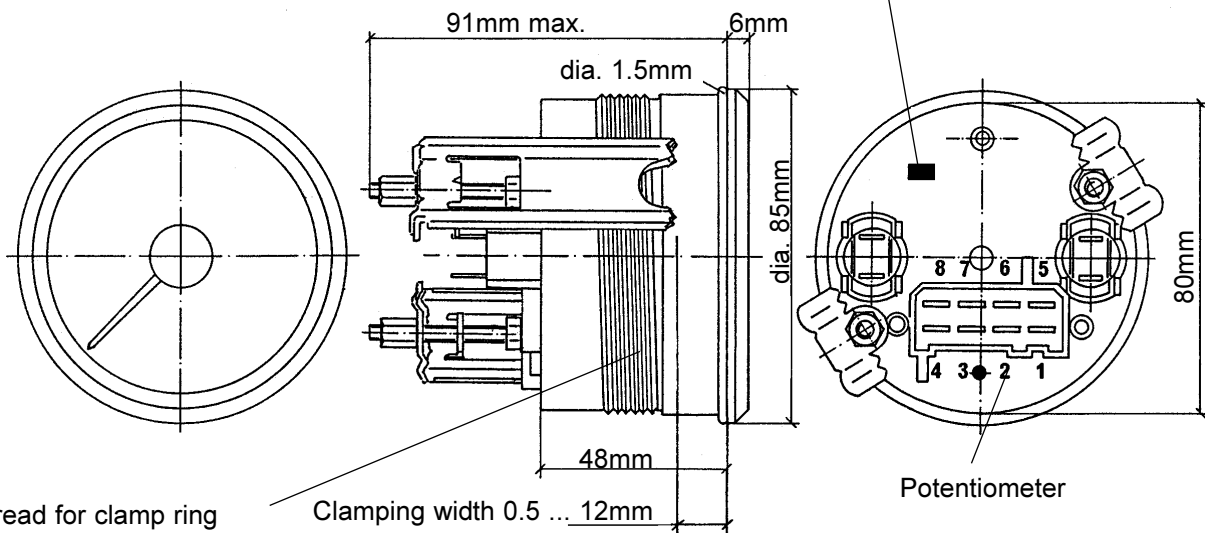

Thread for clamp ring
(clamping width
0.5 ... 12mm or 12 ... 23mm)

6 ... 25 pulses/revolution
(adjustable)

Pin assignment:
Pin 1: + 24 V (for 24 V instrument)
Terminal 15
Pin 2: + 12 V (for 12 V instrument)
Terminal 15
Pin 3: Ground
Pin 4: Signal input
Terminal 1 or W

Technical Product Manual

VDO cockpit vision VDO cockpit international

3. Electronic Tachometer (dia. 80 mm / dia.100 mm)

3.2 Technical Data

Operating voltage:	10.8 ... 16 V or 21 ... 32 V
Input signal voltage:	U_{low} : max. 5 V U_{high} : min. 7,5 V
Movement:	System Ke (\rightarrow 320°)
Pickup:	terminal 1 ignition coil (fuel engine) terminal W alternator (diesel engine)
Current consumption:	< 100 mA (without illumination)
Operating temp.:	- 20°C ... + 70°C
Storage temperature:	- 30°C ... + 85°C
Illumination:	2 light bulbs 12 V, 2 W or 24 V, 2 W
Protection:	IP64 DIN 40050 from the front housing 'ozon'-proof, 'UV'-proof CE approved, reverse-polarity protection
EMC test:	according to EN 13309 and ISO 13766
Vibration resistance:	max. 1g eff., 25 ... 500 Hz, duration 8h, f. 1 octave/min.
Nominal position:	NL 0 to NL 90, DIN 16257

VDO cockpit international
dia. 100 mm Floodlight

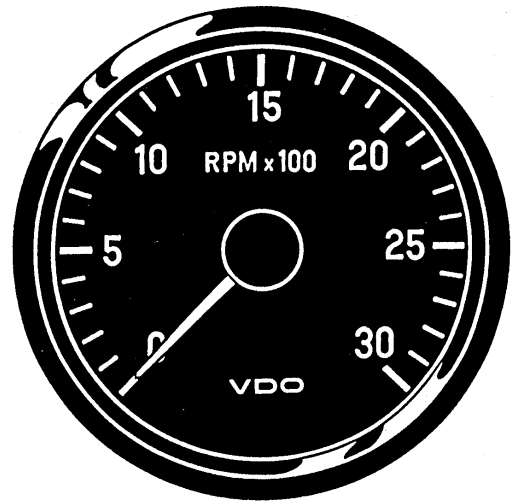

Mounting hole: dia. 101mm

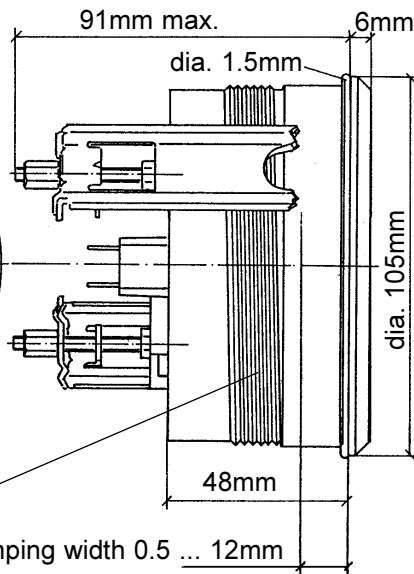
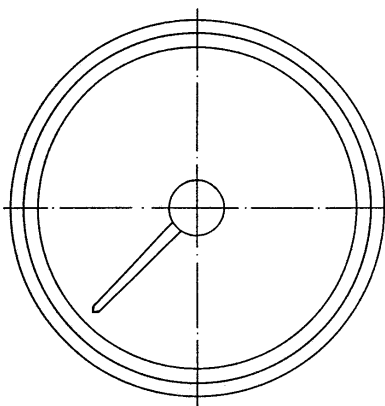

Thread for clamp ring
(Clamping width
0.5 ... 12mm or 12 ... 23mm)

Coding switches

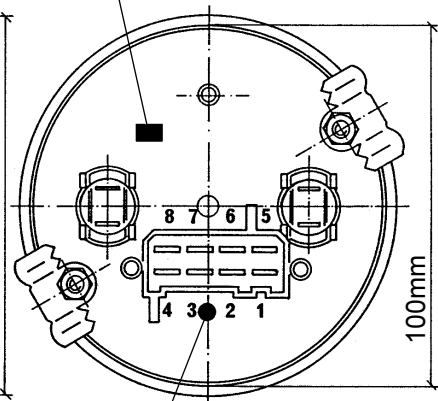

Potentiometer

6 ... 25 pulses/revolution
(adjustable)

Pin assignment:

- Pin 1: + 24 V (for 24 V instrument)
Terminal 15
- Pin 2: + 12 V (for 12 V instrument)
Terminal 15
- Pin 3: Ground
- Pin 4: Signal input
Terminal 1 or W

Technical Product Manual

VDO cockpit vision VDO cockpit international

3. Electronic Tachometer (dia. 80 mm / dia.100 mm)

3.3 Pulsing

Tachometer connection: pin 4

On vehicles with petrol engines the signal is obtained at terminal 1 of the ignition coil in the case of conventional ignition systems (having one coil only) or an additional terminal on special ignition systems. In the case of special ignition systems (such as transistor/coil ignition systems, electronic and fully electronic ignitions) please ask the vehicle manufacturer or the ignition system manufacturer about the correct terminal.

Conventional ignition system

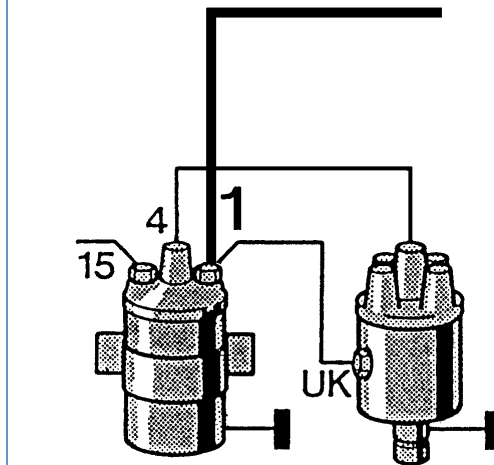

The signal on vehicles with diesel engine is obtained at alternator terminal W.

Alternator

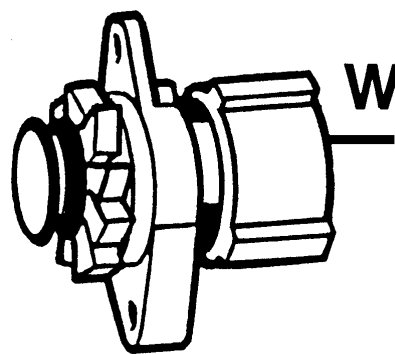

The ignition must be off and the battery minus connection disconnected when connecting the cable.

Technical Product Manual

VDO cockpit vision VDO cockpit international

3. Electronic Tachometer (dia. 80 mm / dia.100 mm)

3.4 Wiring Diagram

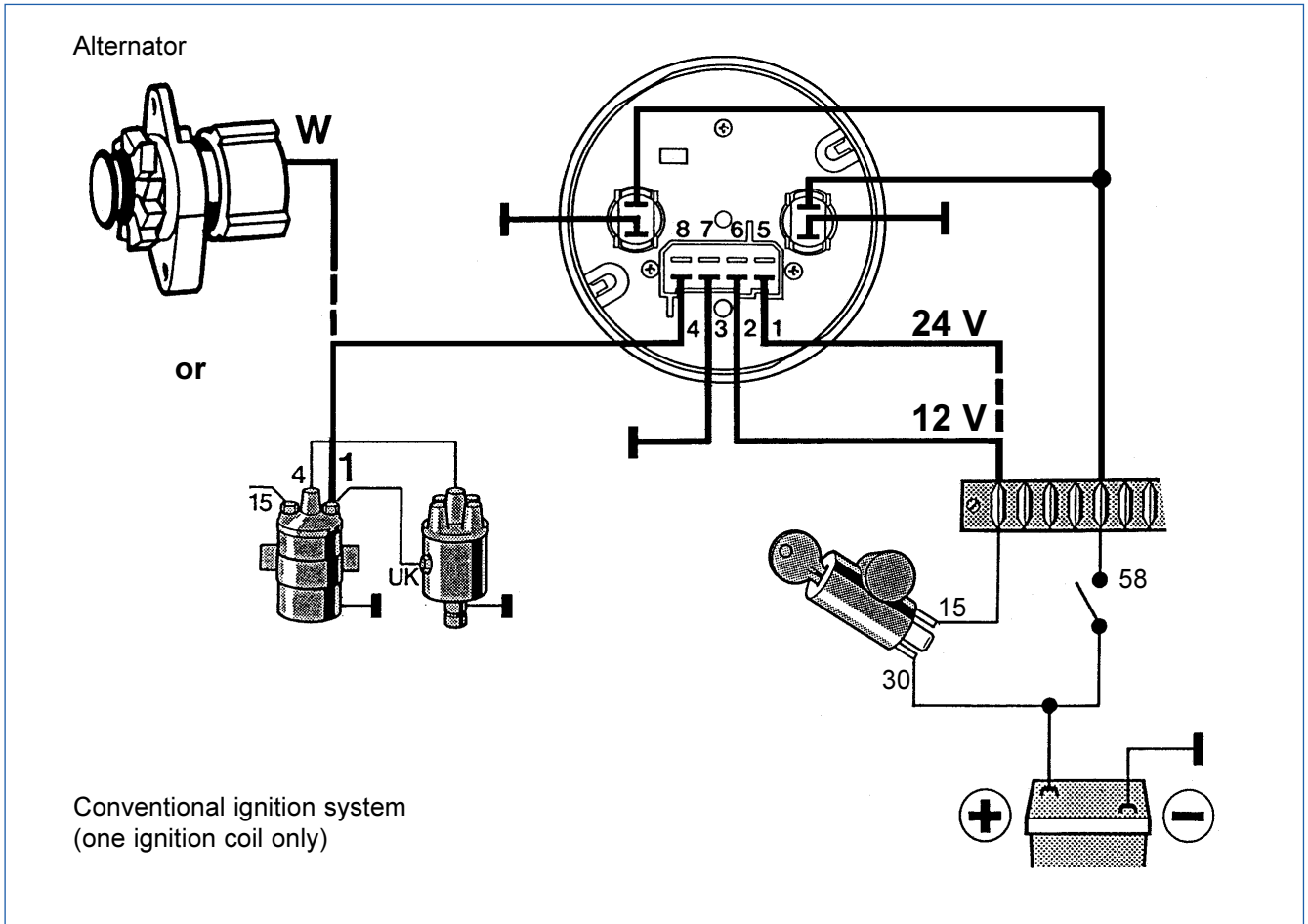

Technical Product Manual

VDO cockpit vision VDO cockpit international

3. Electronic Tachometer (dia. 80 mm / dia.100 mm)

3.5 Setting

Petrol engine setting

For petrol engines (4, 5, 6 or 8 cylinders) and connection to terminal 1 (only one ignition coil) either only use the coding switches for setting or use the coding switches (coarse setting) and use the potentiometer (fine adjustment: see page 3 - 13) for setting.
Possible settings per coding table.

Coding table

Petrol engine, terminal 1 (one ignition coil)					Only coding switches	Coding switches and potentiometer
Coding switches			Cylinders	Stroke	⚠ Do not change the potentiometer setting! Changing the potentiometer setting will cause wrong readings.	Use a reference tachometer to set the potentiometer ▼
1	2	3				
on	off	off	4	4	x	
on	off	off	5	4		x
on	off	on	6	4	x	
on	on	off	8	4	x	

▼ The adjustment must be made by two people, one of them adjusting the instrument, the other one using the hand-held tachometer (reference tachometer), see page 3 -13.

Example:
on, off, off
(4 cylinders, four-stroke)

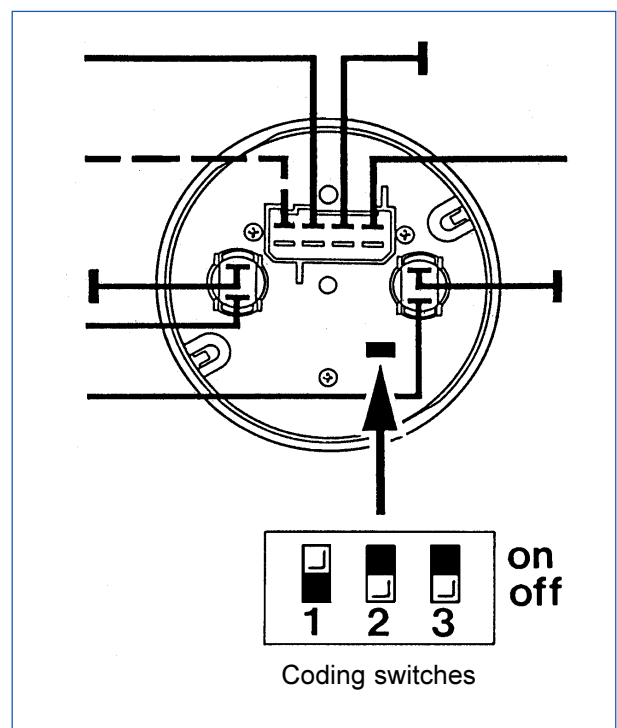

Technical Product Manual

VDO cockpit vision VDO cockpit international

3. Electronic Tachometer (dia. 80 mm / dia.100 mm)

3.5 Setting

Diesel engine setting

For the diesel engine and connection to terminal W of the alternator use the coding switches (coarse setting) and the potentiometer (fine adjustment: see page 3 - 13) for setting.

Set the coding switches per coding table if the pulse ratio (pulses at the terminal W output of the alternator for one engine revolution) is known.

Coding table

Diesel engine, terminal W							
Switches			RPM				
1	2	3	3000	4000	6000	7000	8000
off	off	off	8-12	6-9	8-12	7-10	6-9
off	off	on	12-17	9-13	12-17	10-15	9-13
off	on	off	17-25	13-20	17-24	14-21	12-18
			Pulses per revolution				

Example: off, off, off (at 6000 RPM 10 pulses per revolution).

Make the fine adjustment with the potentiometer (see page 3 - 13).

Technical Product Manual

VDO cockpit vision VDO cockpit international

3. Electronic Tachometer (dia. 80 mm / dia.100 mm)

3.5 Setting

Diesel engine setting

The following formula can be used to calculate an unknown pulse ratio, which is then set as described on page 3 - 11.

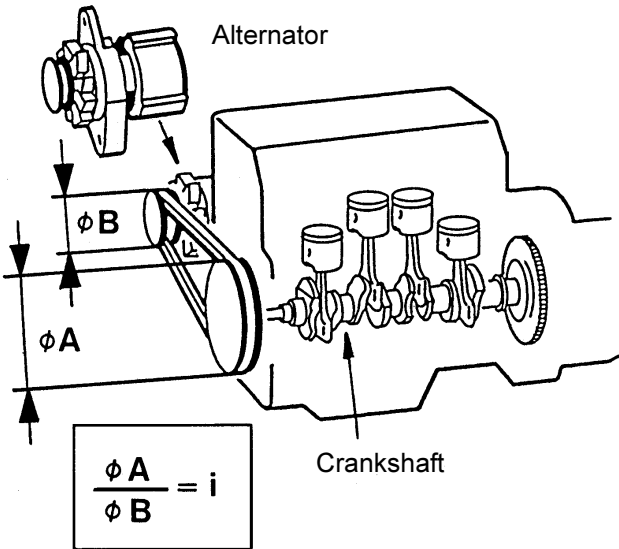

Example:
 dia. A = 280 mm
 dia. B = 132 mm

$$i = \frac{280}{132} = 2.12$$

$i \times 6 = \text{the pulse ratio}$

Pulses per revolution
 Number of the alternator pole pairs
 $2.12 \times 6 = 12.72$
 = 13 pulses per revolution

$$\frac{\phi A}{\phi B} = i$$

Set the coding switches to 'off, off, off' first if the number of alternator pole pairs is not known. Make the fine adjustment with the potentiometer.

Select a different coding switches position and the potentiometer if the indication cannot be matched to the reference instrument indication.

Calculate the pulse ratio as follows if the frequency (Hz) is know, and not the pulse ratio:

$$\frac{\text{Hz} \times 60 \text{ sec.}}{\text{full scale speed}} = \text{pulses/revolution}$$

Example 1733 Hz:

$$\frac{1733 \times 60}{8000} = 12.99 = 13 \text{ pulses/revolution}$$

Formula for frequency (Hz):

$$\frac{\text{pulses/revolution} \times \text{full scale speed}}{60 \text{ sec.}} = \text{Hz}$$

Example:

$$\frac{13 \times 8000}{60} = 1733 \text{ Hz}$$

Technical Product Manual

VDO cockpit vision VDO cockpit international

3. Electronic Tachometer (dia. 80 mm / dia.100 mm)

3.5 Setting

Fine adjustment with potentiometer

The fine adjustment using the potentiometer is only possible between 30% and 100% of the indicating range. Use a reference tachometer (hand-held tachometer) to compare the speed indications.

The adjustment must be made by two people, one of them adjusting the instrument, the other one using the hand-held tachometer.

Measure the engine speed at the crankshaft stub of the engine.

Be very careful! Do not wear loose clothing!

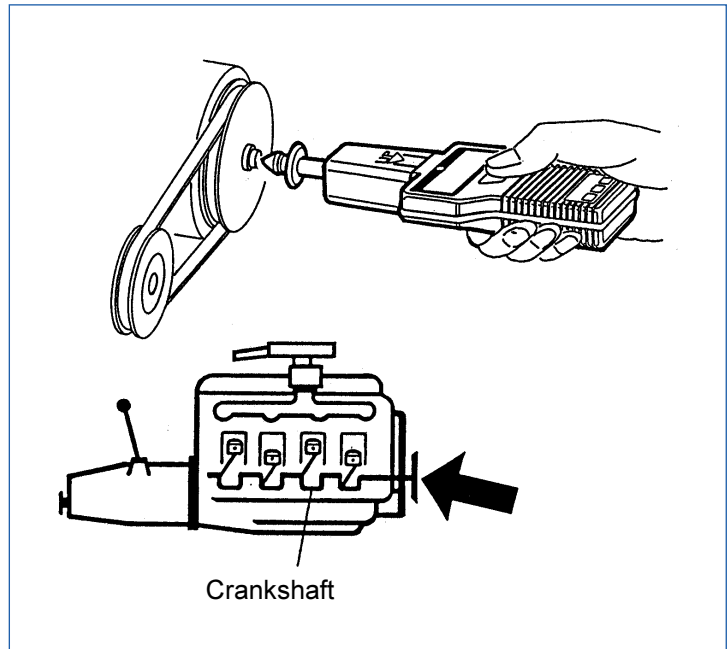

Adjust potentiometer with an insulated screwdriver to the speed indication of the hand-held tachometer.

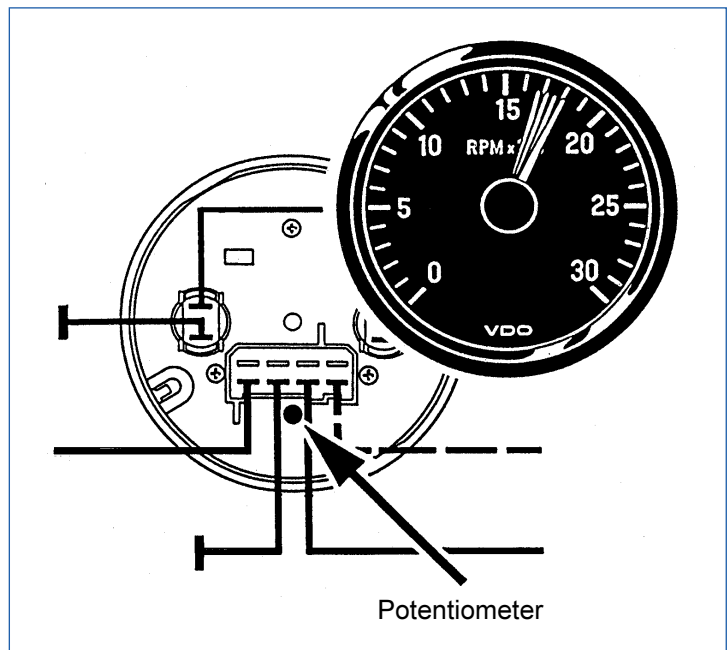

Technical Product Manual

VDO cockpit vision VDO cockpit international

3. Electronic Tachometer (dia. 80 mm / dia.100 mm)

3.6 Testing Instructions

Test accessories

- 1x Power supply
- 1x Test cable No. 1 } contained in test cables kit
- 1x Measuring cable } X12-019-101-001
- 1x Frequency generator
- 1x Ammeter

Connector pin allocation

1	2	3	4
5	6	7	8

- Pin 1 +24V (for 24 V instrument)
- Pin 2 +12V (for 12 V instrument)
- Pin 3 Ground
- Pin 4 Engine speed signal input

Test circuit diagram

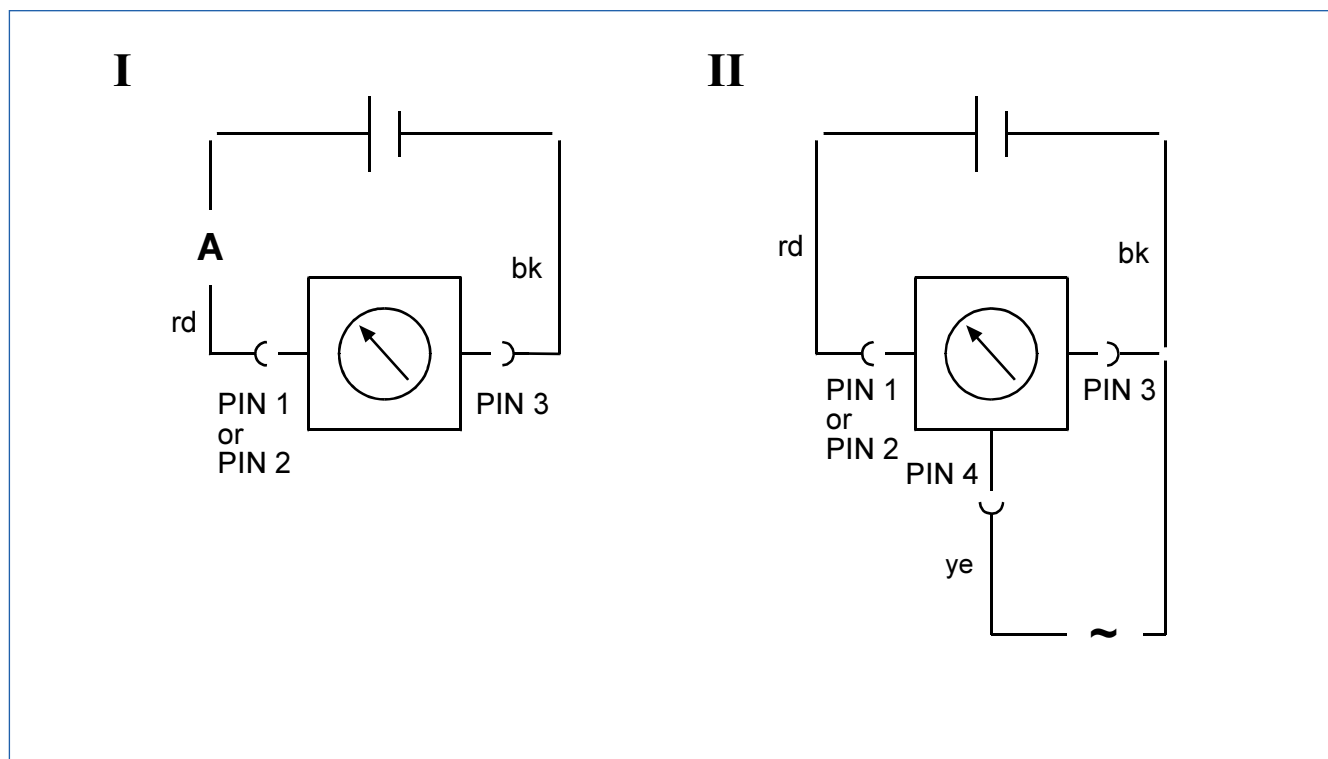



Technical Product Manual

VDO cockpit vision VDO cockpit international

3. Electronic Tachometer (dia. 80 mm / dia.100 mm)

3.6 Testing Instructions



Test method description

Basic setting: 12 V instruments  14V ± 0,2V
 24 V instruments  28V ± 0,4V

Set coding switches (at back of instrument) 1-on, 2-off, 3-off .

Current consumption measurement

Connect the instrument per test circuit diagram I with test cable No. 1.

Value range: 12 V instruments  I = 69 ± 10 mA
 24 V instruments  I = 78 ± 10 mA

Pointer position check

a) Check of zero position

Connect the instrument per test circuit diagram I with test cable No. 1.

Switch operating voltage on and check pointer deviation. The allowed deviation is ± 2 angular degrees.

b) Check of full range position

Connect the instrument per test circuit diagram II with test cable No. 1.

Connect a square wave signal with a frequency corresponding to full range to pin 4. The amplitude shall be at least 10 V.

Engine speed range	Frequency	Tolerance
3000 RPM	100 Hz	± 75 RPM
4000 RPM	133 Hz	± 100 RPM
6000 RPM	200 Hz	± 150 RPM
7000 RPM	233 Hz	± 175 RPM
8000 RPM	267 Hz	± 200 RPM
10000 RPM	333 Hz	± 250 RPM

Technical Product Manual

VDO cockpit vision VDO cockpit international

3. Electronic Tachometer (dia. 80 mm / dia.100 mm)

3.7 Instruments Survey

VDO cockpit vision (Backlight) dia. 80 mm / dia. 100 mm

Part No. 333-015-...

Dial		Special feature	Part No.
Range	Imprint		
0 ... 7000 min ⁻¹	RPM x 100	12 V, dia. 80 mm	001K
0 ... 8000 min ⁻¹	RPM x 100	12 V, dia. 100 mm	005G

Technical Product Manual

VDO cockpit vision VDO cockpit international

3. Electronic Tachometer (dia. 80 mm / dia.100 mm)

3.7 Instruments Survey

VDO cockpit international (Floodlight) dia. 80 mm

Part No. 333-035- . . .

Dial		Special feature	Part No.
Range	Imprint		
0 ... 3000 min ⁻¹	RPM x 100	12 V, dia. 80 mm	001C 001G
0 ... 4000 min ⁻¹	RPM x 100	12 V, dia. 80 mm	002C * 002G
0 ... 7000 min ⁻¹	RPM x 100	12 V, dia. 80 mm	003C * 003G
0 ... 10000 min ⁻¹	RPM x 100	12 V, dia. 80 mm	022C
0 ... 4000 min ⁻¹	RPM x 100	12 V, dia. 80 mm ●	027C

● with clamp ring instead of bolts and brackets

Part No. 333-045- . . .

Dial		Special feature	Part No.
Range	Imprint		
0 ... 3000 min ⁻¹	RPM x 100	24 V, dia. 80 mm	001C 001G
0 ... 4000 min ⁻¹	RPM x 100	24 V, dia. 80 mm	002C 002G

VDO cockpit international (Floodlight) dia. 100 mm

Part No. 333-055- . . .

Dial		Special feature	Part No.
Range	Imprint		
0 ... 3000 min ⁻¹	RPM x 100	12 V, dia. 100 mm	001C * 001G

Part No. 333-065- . . .

Dial		Special feature	Part No.
Range	Imprint		
0 ... 3000 min ⁻¹	RPM x 100	24 V, dia. 100 mm	001C * 001G

* Phase-out

Technical Product Manual

VDO cockpit vision VDO cockpit international

4. Electronic Tachometer With Operating Hours Counter (dia. 80 mm / dia.100 mm) only for VDO cockpit international

Contents	Page
4.1 General informations	4 - 2
4.2 Technical data	4 - 4
4.3 Pulsing	4 - 6
4.4 Wiring diagrams	4 - 7
4.5 Setting	4 - 9
4.6 Display	4 - 16
4.7 Testing instructions	4 - 17
4.8 Instruments survey	4 - 19

Installation instructions

999-165-009: VDO cockpit international

See file 'Installation Instructions (MA)'.

Technical Product Manual

VDO cockpit vision VDO cockpit international

4. Electronic Tachometer With Operating Hours Counter (dia. 80 mm / dia.100 mm) only for VDO cockpit international

4.1 General Informations

The electronic tachometer with operating hours counter has been designed for land-bound vehicles or stationary systems only (with the exception of motorcycles).

The instrument has an analog engine speed indication in RPM x 100 and a liquid crystal display for the operation hours count.

The electronic tachometer is pulsed by an inductive sensor or a generator sensor or by the terminal W of the alternator in the case of diesel engines, by terminal 1 of ignition coil in the case of petrol engines.

The instrument is set by a pushbutton at the back of the instrument.



The lamp sockets are clipped in.
To replace the light bulb, carefully, with the thumb,
push the lamp holder out to the side.

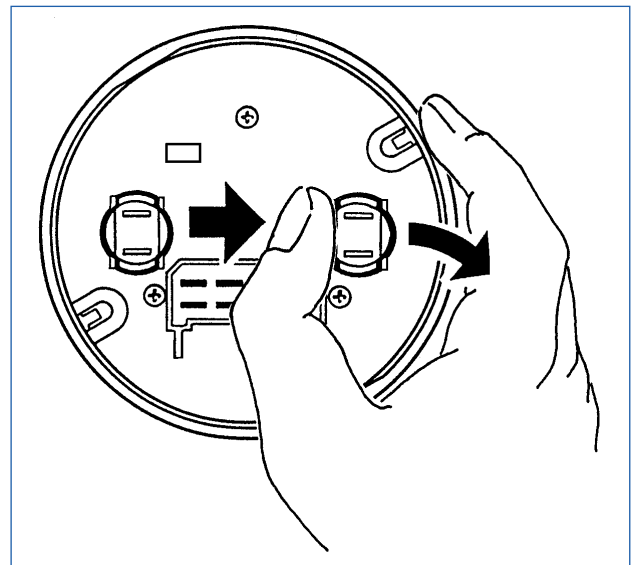

Technical Product Manual

VDO cockpit vision VDO cockpit international

4. Electronic Tachometer With Operating Hours Counter (dia. 80 mm / dia.100 mm) only for VDO cockpit international

4.1 General Informations

Designation of function

Stepper motor movement

The drive for this display system is a stepper motor, comprising a permanent magnet rotor within a crossed winding arrangement. A zero backlash gearbox at the output ensures a high drive torque and fine resolution. The gearbox has a reduction ratio of 43.2 : 1 and an internal mechanical stop. The stepper motor drive was developed specially by VDO for this product.

The drive produces a bipolar sinusoidal variable voltage using digital pulse width modulation. There is a 90° phase difference (sine-cosine) between the voltages on the two motor coils. This rotates the electromagnetic field through equidistant angular steps with a constant length resultant vector ($\sin^2\theta + \cos^2\theta = 1$).

The motor torque is therefore constant at each step with zero cogging. At the pointer one motor step equals 0.065°.

The stepper motor parameters and the design of VDO control-driver electronics are carefully matched to ensure reliable operation of the system under all conditions. Optimised control algorithms ensure a visually smooth pointer motion.

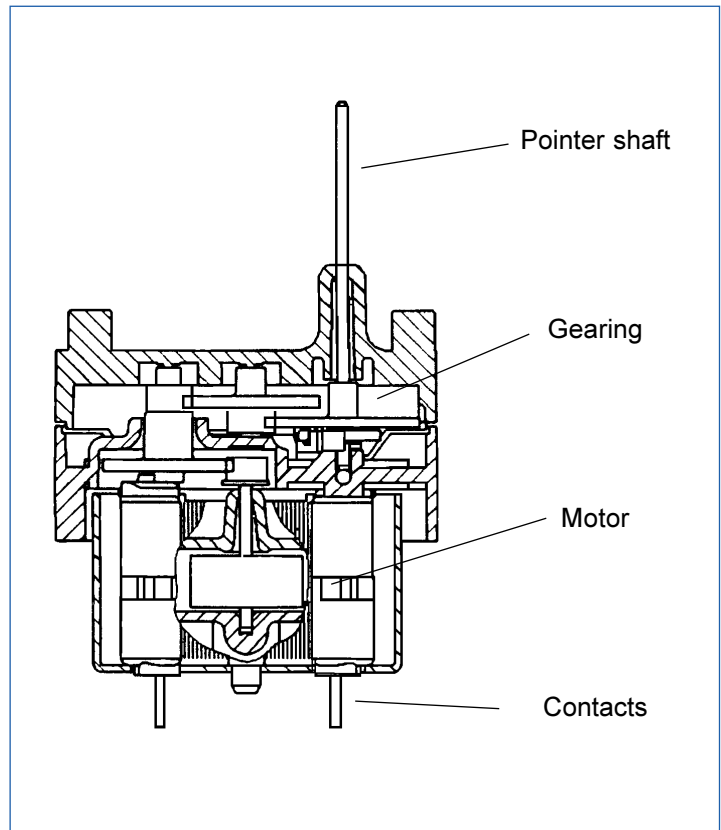

Technical Product Manual

VDO cockpit vision VDO cockpit international

4. Electronic Tachometer With Operating Hours Counter (dia. 80 mm / dia.100 mm) only for VDO cockpit international

4.2 Technical Data

Operating voltage:	10 ... 31 V
Input signal voltage:	U_{low} : 0 V U_{high} : min. 1 V
Movement:	Stepper motor
Pickup:	Terminal 1 ignition coil (petrol engine) or Terminal W alternator (diesel engine) Inductive sensor or Generator sensor
Current consumption:	< 100 mA (120 mA with illumination) < 0,1 mA standby
Operating temp.:	- 20°C ... + 70°C
Storage temperature:	- 30°C ... + 85°C
Illumination:	2 light bulbs, 12 V, 2 W or 24 V, 2 W
Protection:	IP64 DIN 40050 from the front Housing 'ozon'-proof, 'UV'-proof CE approved, reverse-polarity protection
EMC test:	according to EN 13309 and ISO 13766
Vibration resistance:	max. 1g eff., 25 ... 500 Hz, duration 8h, f. 1 octave/min.
Nominal position:	NL 0 to NL 90, DIN 16257

VDO cockpit international
dia. 80 mm Floodlight

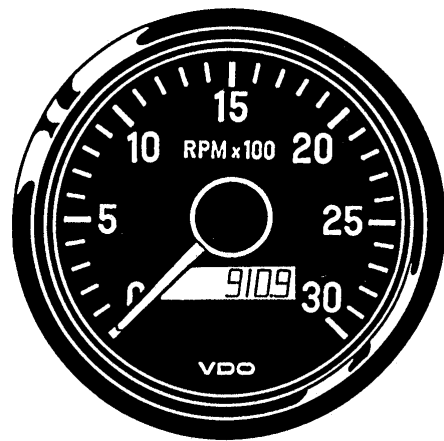

Operating hours counter: 999999.9h

Mounting hole: dia. 81mm

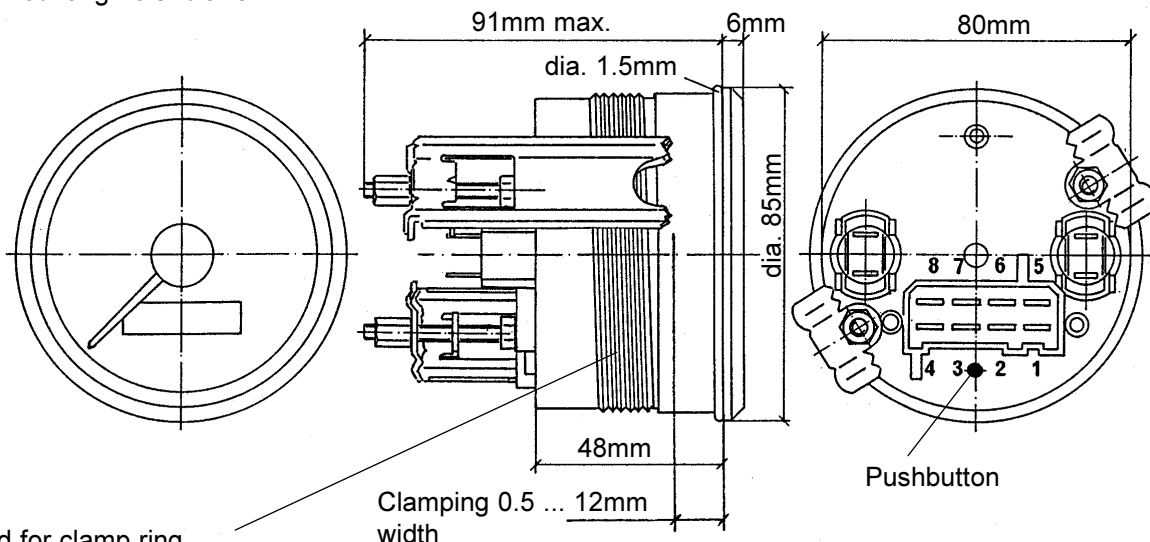

Thread for clamp ring
(clamping width 0.5 ... 12mm
or 12 ... 23mm)

0.5 ... 399.99 pulses / revolution
(adjustable)

* Not available on some instruments.

Pin assignment:

Pin 3: ground, terminal 31

Pin 4: + 12 V or + 24 V, terminal 15

Pin 5*: permanent positive pole 12 V / 24 V,
terminal 30

Pin 7: signal input
inductive sensor, generator sensor
(2 signal wires)

Pin 8: terminal 1 or W (1 signal wire)
or inductive sensor, generator sensor
(2 signal wires)

Technical Product Manual

VDO cockpit vision VDO cockpit international

4. Electronic Tachometer With Operating Hours Counter (dia. 80 mm / dia.100 mm) only for VDO cockpit international

4.2 Technical Data

Operating voltage:	10 ... 31 V
Input signal voltage:	U_{low} : 0 V U_{high} : min. 1 V
Movement:	Stepper motor
Pickup:	Terminal 1 ignition coil (petrol engine) or Terminal W alternator (diesel engine) Inductive sensor or Generator sensor
Current consumption:	< 100 mA (120 mA with illumination) < 0.1 mA standby
Operating temp.:	- 20°C ... + 70°C
Storage temperature:	- 30°C ... + 85°C
Illumination:	2 light bulbs, 12 V, 2 W or 24 V, 2 W
Protection:	IP64 DIN 40050 from the front Housing 'ozon'-proof, 'UV'-proof CE approved, reverse-polarity protection
EMC test:	according to EN 13309 and ISO 13766
Vibration resistance:	max. 1g eff., 25 ... 500 Hz, duration 8h, f: 1 octave/min.
Nominal position:	NL 0 to NL 90, DIN 16257

VDO cockpit international
dia. 100 mm Floodlight

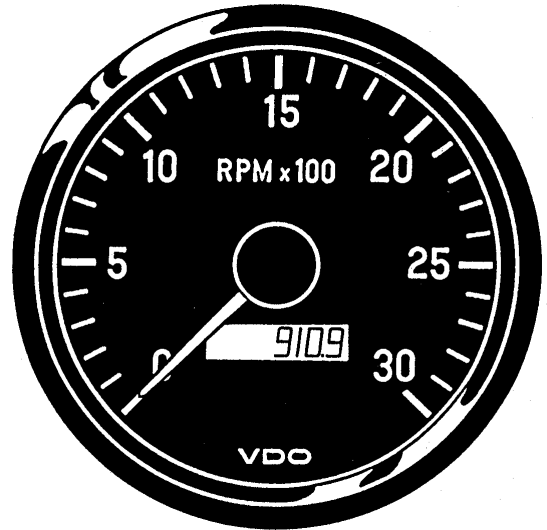

Operating hours counter: 999999.9 h

Mounting hole: dia.101mm

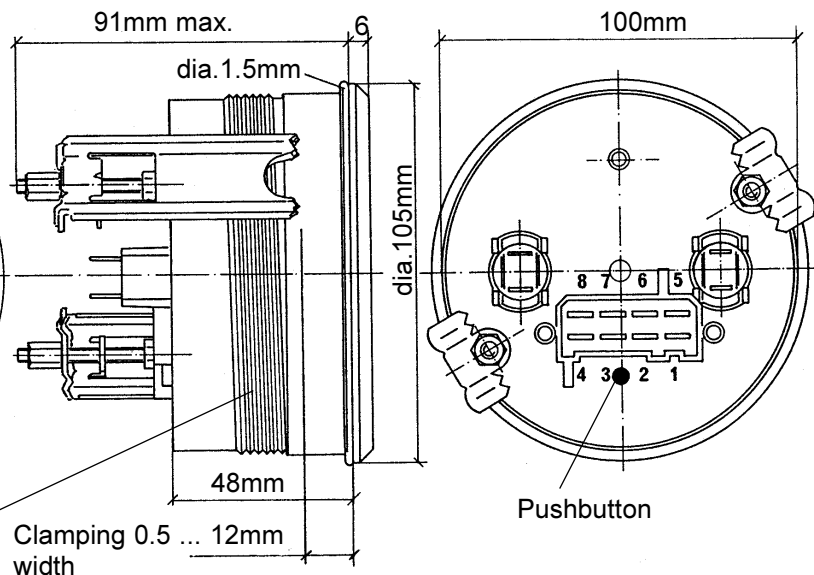
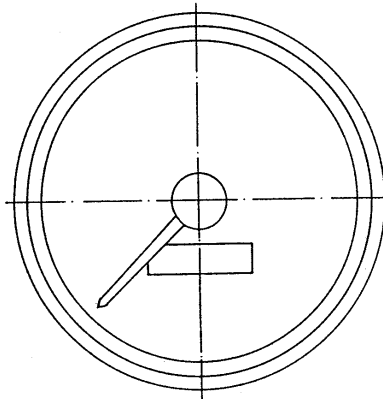

Thread for clamp ring
(clamping width 0.5 ... 12mm
or 12 ... 23mm)

0.5 ... 399.99 pulses /revolution
(adjustable)

* Not available on some instruments.

Pin assignment:

- Pin 3: ground, terminal 31
- Pin 4: + 12 V or + 24 V, terminal 15
- Pin 5*: permanent positive pole 12 V / 24 V,
terminal 30
- Pin 7: signal input
inductive sensor, generator sensor
(2 signal wires)
- Pin 8: terminal 1 or W (1 signal wire)
or inductive sensor, generator sensor
(2 signal wires)

Technical Product Manual

VDO cockpit vision VDO cockpit international

4. Electronic Tachometer With Operating Hours Counter (dia. 80 mm / dia.100 mm) only for VDO cockpit international

4.3 Pulsing

The sensor needed for the pulsing of the tachometer with operating hours counter is not included in the shipment. The following sensors (see data sheets for sensors) can be used:

Inductive sensor

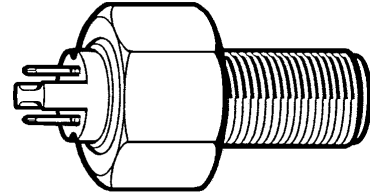

Tachometer connections: pin 7 and pin 8

Generator sensor

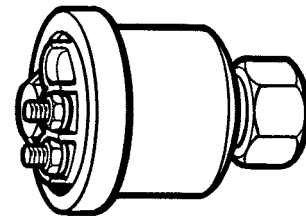

The pulsing can also be obtained from:

- Terminal W of the alternator of diesel-engine equipped vehicles.

Alternator

Tachometer connection pin 8

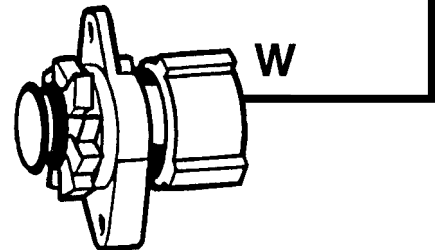

- Terminal 1 of the ignition coil in the case of conventional ignition systems (with one or more ignition coils), or a special terminal for special ignition systems of petrol engines. In the case of special ignition systems (such as transistor-coil ignitions, electronic and fully electronic ignition systems) please ask the vehicle manufacturer or the ignition system manufacturer for the correct terminal.

Conventional ignition system

Tachometer connection pin 8

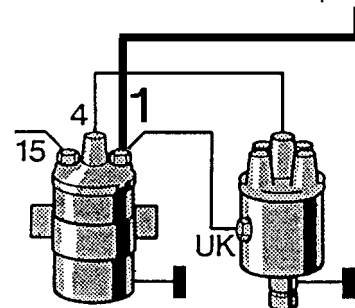

Ignition must be off and minus battery connection disconnected when connecting the cable.

Technical Product Manual

VDO cockpit vision VDO cockpit international

4. Electronic Tachometer With Operating Hours Counter (dia. 80 mm / dia.100 mm) only for VDO cockpit international

4.4 Wiring Diagrams

Inductive sensor
(2 signal wires)

Note:



Pin 5 is not available on instruments produced before week 18/99.

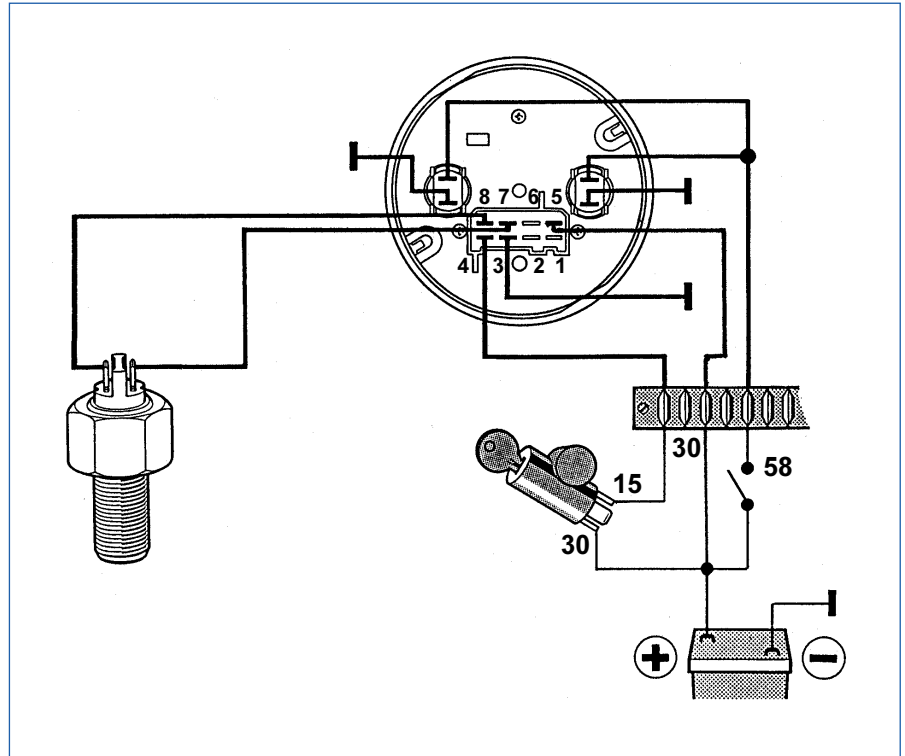

Generator sensor
(2 signal wires)

Note:



Pin 5 is not available on instruments produced before week 18/99.

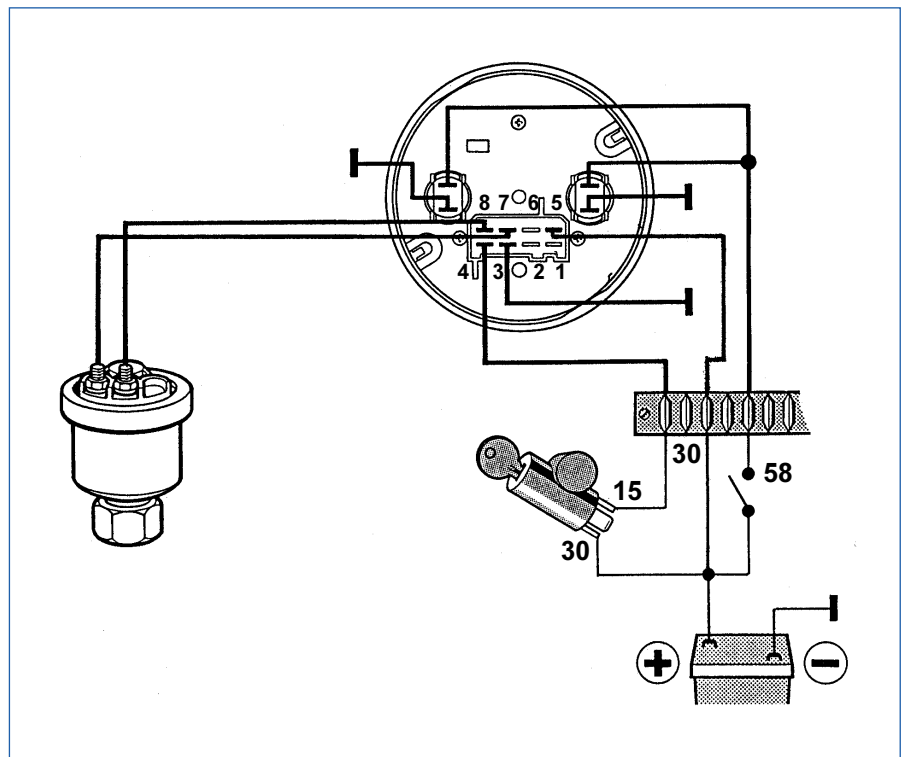

Technical Product Manual

VDO cockpit vision VDO cockpit international

4. Electronic Tachometer With Operating Hours Counter (dia. 80 mm / dia.100 mm) only for VDO cockpit international

4.4 Wiring Diagrams

Alternator

Note:



Pin 5 is not available on instruments produced before week 18/99.

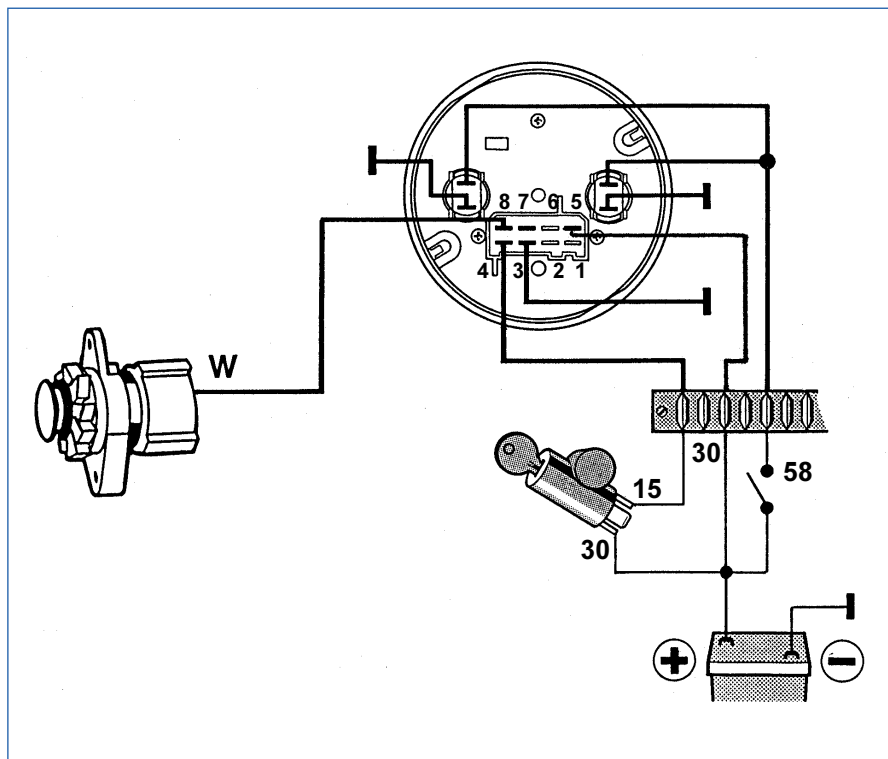

Conventional ignition system (one or more ignition coils)

Note:



Pin 5 is not available on instruments produced before week 18/99.

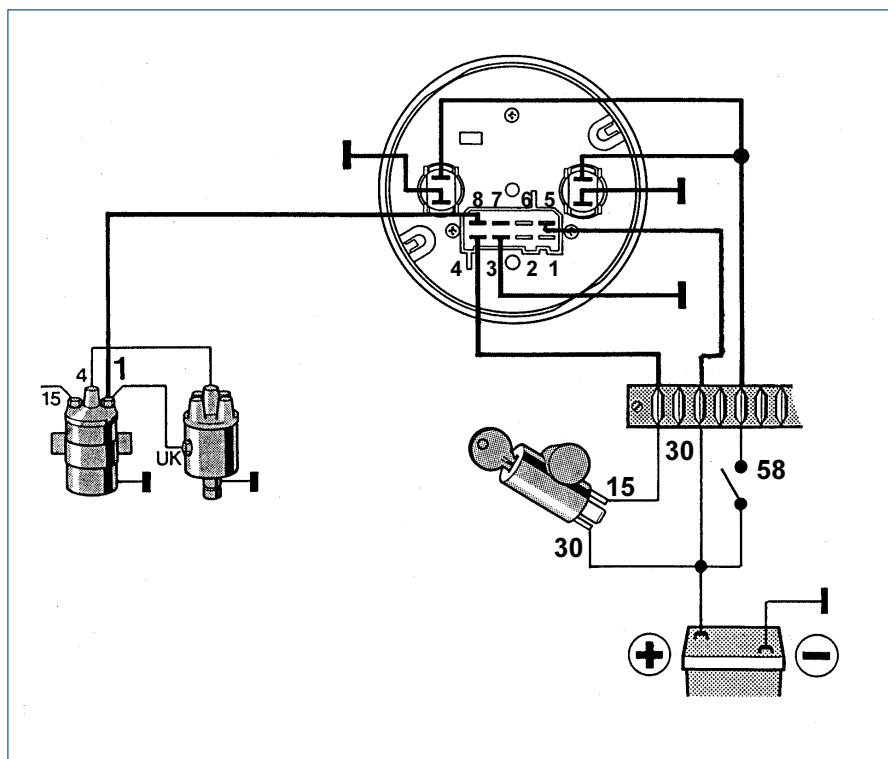

Technical Product Manual

VDO cockpit vision VDO cockpit international

4. Electronic Tachometer With Operating Hours Counter (dia. 80 mm / dia.100 mm) only for VDO cockpit international

4.5 Setting

Four possible settings are available for the electronic tachometer with operating hours counter.

Two possible calibrations:

Function 'SELECT' - Enter the stroke number and the number of cylinders for vehicles with petrol engine (two-stroke or four-stroke) when connecting to terminal 1 of the ignition coil (ignition systems having only one ignition coil).



Not apply for vehicles with diesel engine.

Function 'PULSE' - Enter a know number of pulses per revolution for:

inductive sensor,

generator sensor,

connection to terminal W of the alternator on vehicles with diesel engines,

connection to terminal 1 of ignition coil (ignition systems having one or more ignition coils) for vehicles with petrol engine (two-stroke or four-stroke).

Two possible fine adjustments of the engine speed indication:

Function 'AdJUST' - Fine adjustment of engine speed indication (continuous pointer adjustment)

or

Function 'A' - Fine adjustment of engine speed indication (pointer adjustment in percentage steps).

Technical Product Manual

VDO cockpit vision VDO cockpit international

4. Electronic Tachometer With Operating Hours Counter (dia. 80 mm / dia.100 mm) only for VDO cockpit international

4.5 Setting

Selection of the functions: 'SELECT', 'PULSE' or 'AdJUST'

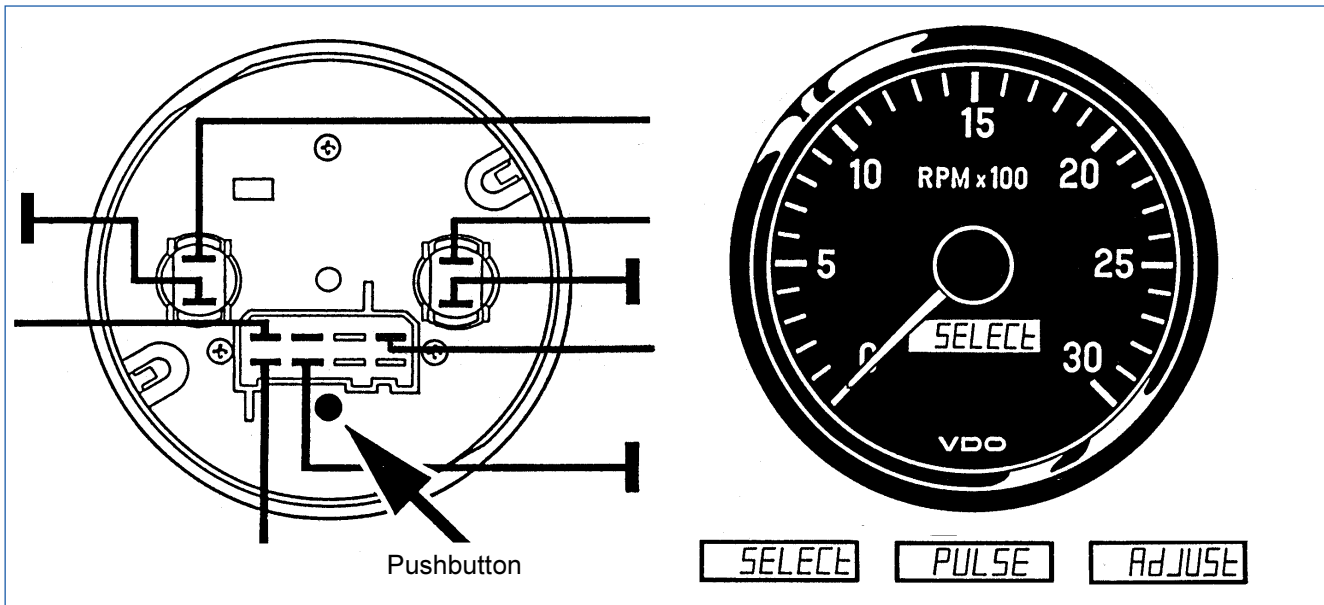

Push the button on the back of the instrument and hold, then switch the ignition on. The display alternates between 'SELECT', 'PULSE' and 'AdJUST'. A function is selected by releasing the pushbutton at the corresponding display.

Selection of the function: 'A'

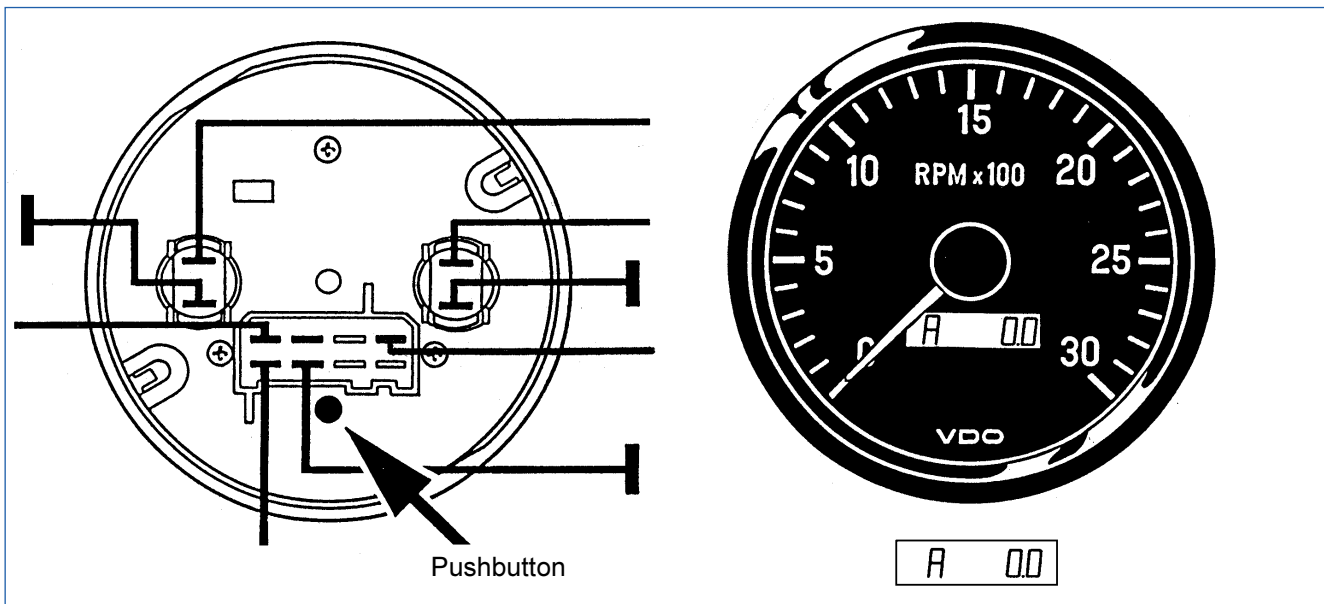

Switch ignition on, then push the button at the back of the instrument. The display shows 'A 0.0'.

Technical Product Manual

VDO cockpit vision VDO cockpit international

4. Electronic Tachometer With Operating Hours Counter (dia. 80 mm / dia.100 mm) only for VDO cockpit international

4.5 Setting

Function 'SELECT'

After selection of the function 'SELECT' the display shows '4 - 8 C' (four-stroke, 8 cylinders) for instance after about 3 seconds.

Push the button in and hold. The display shows the possible settings for:

four-stroke, 1, 2, 3, 4, 5, 6, 8, 12 cylinders
(example: '4 - 8 C' = four-stroke, 8 cylinders),

two-stroke, 1, 2, 3, 4 cylinders
(example: '2 - 3 C' = two-stroke, 3 cylinders).

Release the pushbutton when the corresponding stroke and cylinder numbers are attained. The calibration is completed if the display thereafter changes to operating hours counter.

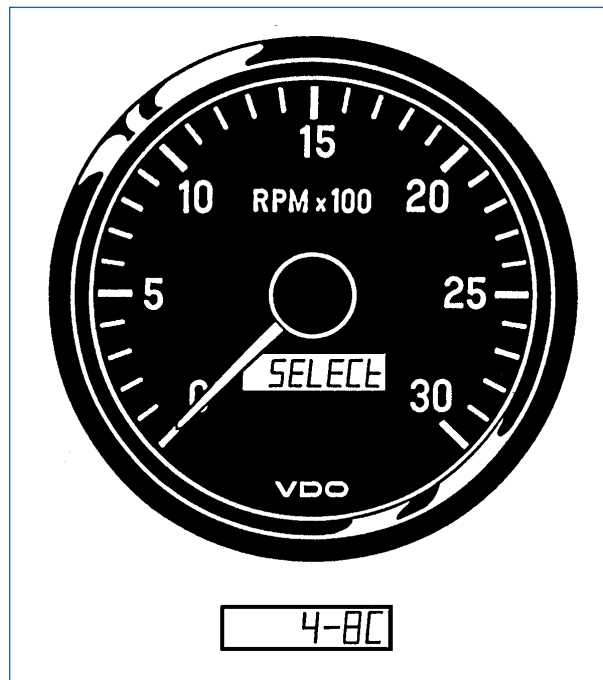

Technical Product Manual

VDO cockpit vision VDO cockpit international

4. Electronic Tachometer With Operating Hours Counter (dia. 80 mm / dia.100 mm) only for VDO cockpit international

4.5 Setting

Function 'PULSE'

After selection of the function 'PULSE' the display shows 'P 14.50' for instance (14.50 pulses per revolution) after about three seconds, with the digit before the last flashing. Start entering the know pulse number per revolution. The flashing digit is changed by pushing the button (adjustable number of pulses revolution: 0.50 to 399.99). After entry of the number of pulses per revolution the display changes to operating hours counter mode. The calibration is completed.

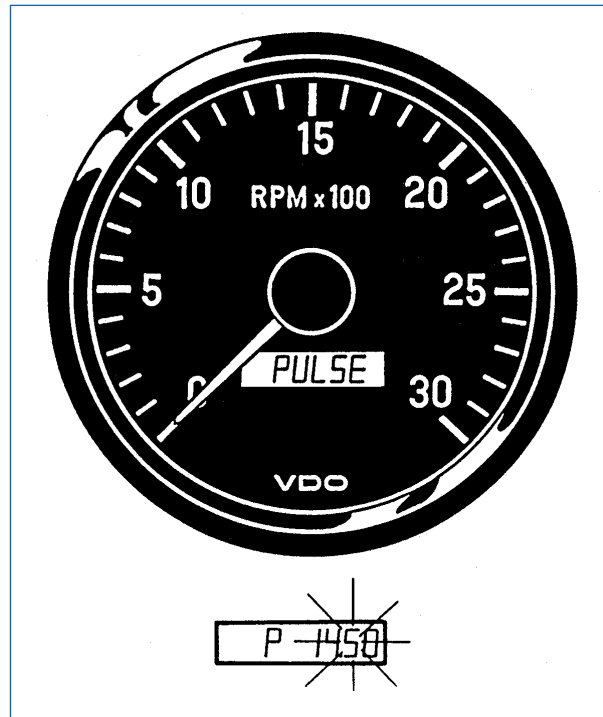

Selecting the function 'PULSE' again displays the entered number of pulses per revolution for checking. The display shows the number of pulses per revolution, and the last digits, starting with the digit, start flashing in a sequence.

The number of pulses per revolution can be calculated with following formula if it is not know:

Conventional ignition system:

$$\frac{\text{pulses}}{\text{revolution}} = \frac{2 \times \text{number of cylinders}}{\text{number of strokes} \times \text{number of ignition coils}}$$

↓
(two-stroke or four-stroke)

or it can be obtained from the engine manufacturer.

Technical Product Manual

VDO cockpit vision VDO cockpit international

4. Electronic Tachometer With Operating Hours Counter (dia. 80 mm / dia.100 mm) only for VDO cockpit international

4.5 Setting

Function 'PULSE'

Diesel engine

The following formula can be used to calculate an unknown pulse ratio, which is then set described on page 4 - 12.

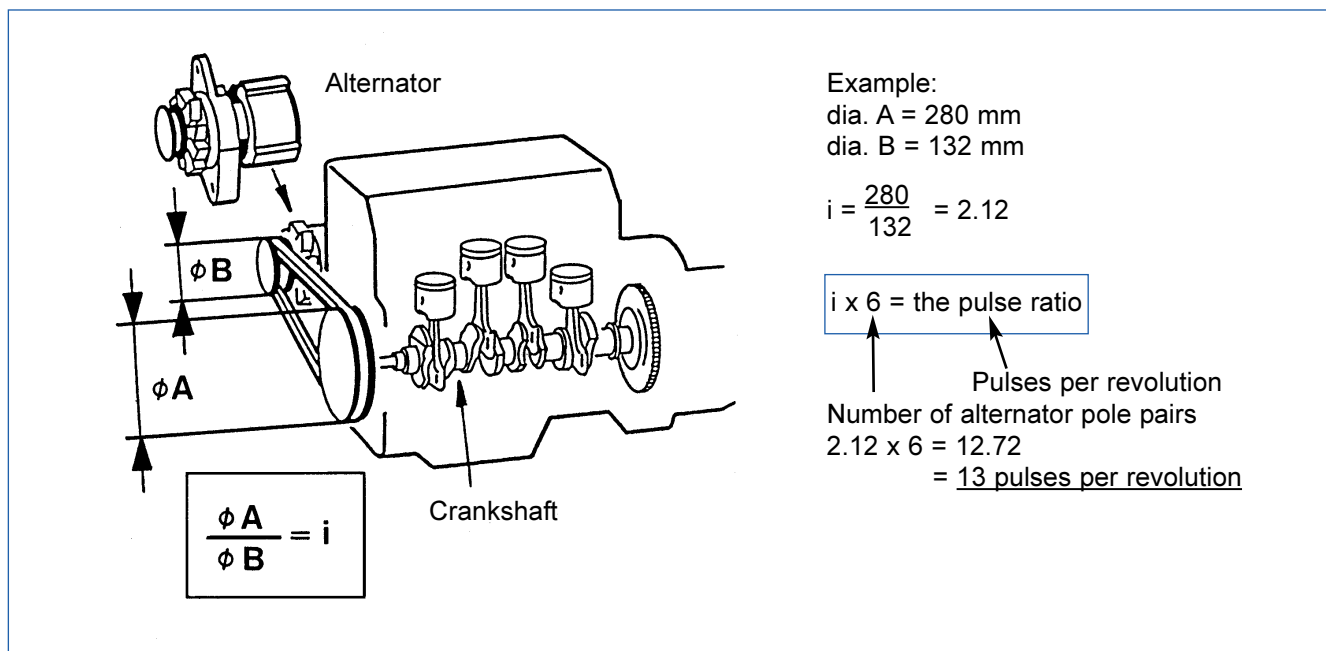

Calculate the pulse ratio as follows if the frequency (Hz) is know, and not the pulse ratio:

Example 1733 Hz:

$$\frac{\text{Hz} \times 60 \text{ sec.}}{\text{full scale speed}} = \text{pulses per revolution}$$

$$\frac{1733 \times 60}{8000} = 12.99 = 13 \text{ pulses per revolution}$$

Formula for frequency (Hz):

$$\frac{\text{pulses per revolution} \times \text{full scale speed}}{60 \text{ sec.}} = \text{Hz}$$

Example:

$$\frac{13 \times 8000}{60} = 1733 \text{ Hz}$$

Technical Product Manual

VDO cockpit vision VDO cockpit international

4. Electronic Tachometer With Operating Hours Counter (dia. 80 mm / dia.100 mm) only for VDO cockpit international

4.5 Setting

Function 'AdJUST' – fine adjustment of engine speed indication (continuous pointer adjustment)

This function permits fine engine speed indication adjustment between 30% and 100% of the indicating range only. Use a reference tachometer (hand-held tachometer) to compare the speed indications.

The adjustment must be made by two people, one of them adjusting the instrument, the other one using the hand-held tachometer. Measure the engine speed at the crankshaft stub of the engine with the hand-held tachometer. Be very careful! Do not wear loose clothing!

The selection of function 'AdJUST' alternately displays 'UP' or 'dn' (down).

Holding the button down with the 'UP' display increments the pointer position (in the same way it will decrement if 'dn' is displayed). Initially the rate of change is quite low, permitting a very precise adjustment. Shortly releasing the button will repeat the process. The rate of pointer position change increases when the button is held down. Release the button when the pointer indication matches the reference indication. The display changes to operation hours count, fine adjustment is completed.

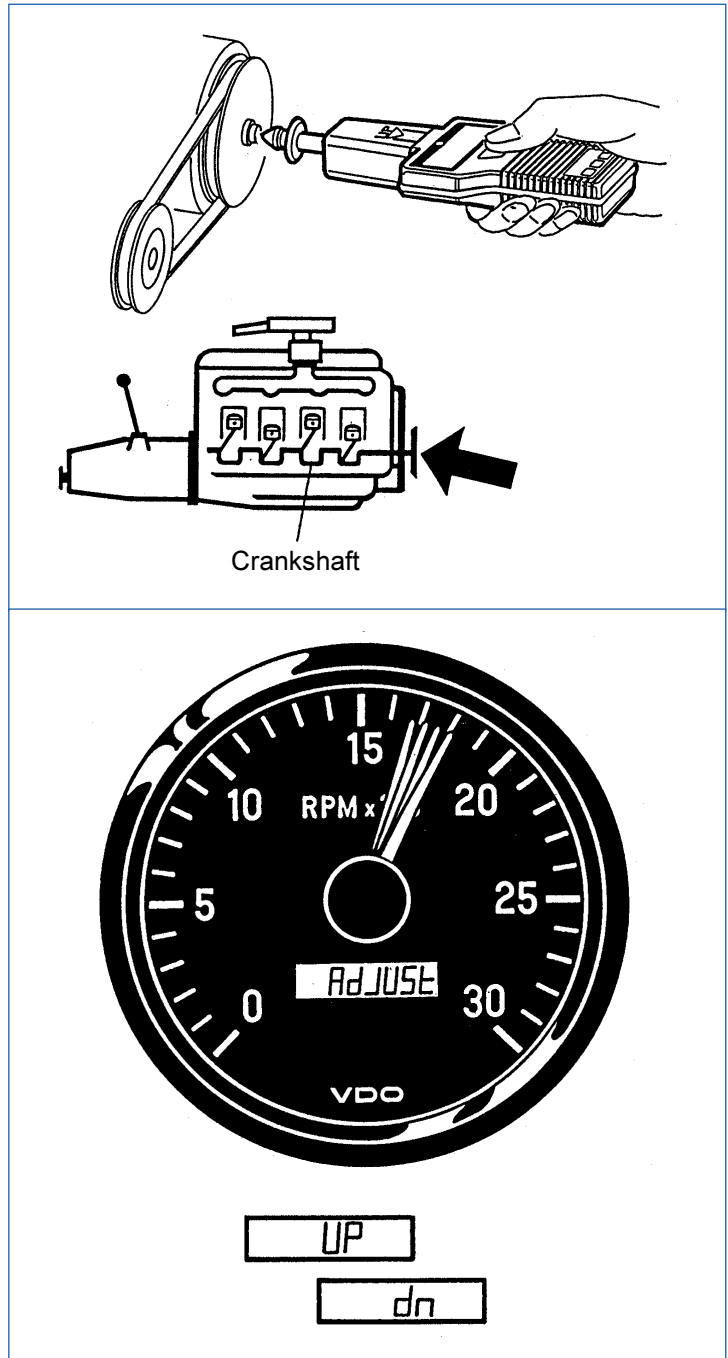

Technical Product Manual

VDO cockpit vision VDO cockpit international

4. Electronic Tachometer With Operating Hours Counter (dia. 80 mm / dia.100 mm) only for VDO cockpit international

4.5 Setting

Function 'A' – fine adjustment of engine speed indication (pointer adjustment in percentage steps)

This function can be used for fine adjustment of the engine speed indication over the entire indicating range in angular steps of 0.5 degrees. Use a reference tachometer (hand-held tachometer) to compare the speed indications.

The display shows 'A 0.0' when the function 'A' is selected.

Push and hold the button to change the pointer deflection in a range of - 20 % to + 20 % in steps of 0.5 %.

These steps are shown by the display:

example in the plus range: 'A 10.5',

example in the minus range: 'A - 10.5'.

Plus and minus change if the pushbutton is briefly released.

Release the pushbutton when the desired percentage is attained. The display returns to the operating hours counter mode. Fine adjustment has been completed.

Calculation of the percentage value:

Find the difference between the tachometer display and the reference speed indication. Calculate the percentage and enter the corresponding value.

Percentage formula:

$$\pm \% = \frac{\text{difference between tachometer reading and reference reading}}{\text{tachometer reading}} \times 100$$

Example for the plus range:

tachometer reading = 1800 RPM
reference speed reading = 2000 RPM
difference = + 200 RPM

$$+ \% = \frac{200 \times 100}{1800} = + 11.11 \%$$

Percentage for fine adjustment: 'A 11.0'

Example for minus range:

tachometer reading = 2200 RPM
Reference speed reading = 2000 RPM
difference = - 200 RPM

$$- \% = \frac{200 \times 100}{2200} = - 9.09 \%$$

Percentage for fine adjustment: 'A - 9.0'

Technical Product Manual

VDO cockpit vision VDO cockpit international

4. Electronic Tachometer With Operating Hours Counter (dia. 80 mm / dia.100 mm) only for VDO cockpit international

4.6 Display

Engine speed display

Tachometer **without** pin 5 (permanent positive pole 12 V/ 24 V)
Only produced before week 18/99.

Note:



When the ignition is switched off, the pointer remains at the last engine speed indicated, until the ignition is switched on again, without starting the engine, the pointer will then return to the zero position.

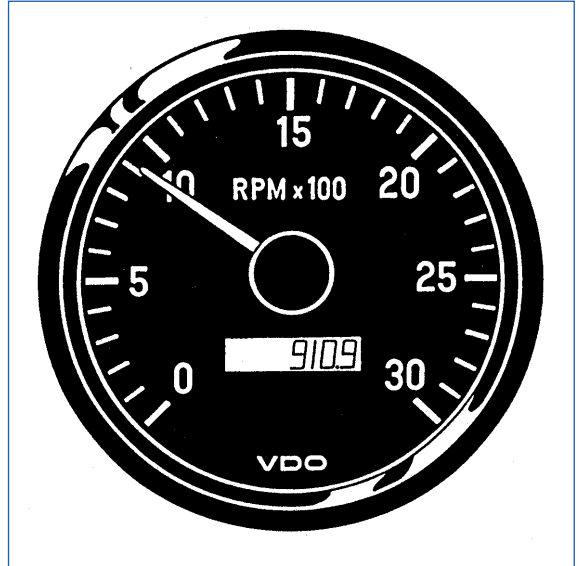

Tachometer **with** pin 5 (permanent positive pole 12 V/ 24 V)

Note:



When the ignition is switched off, the pointer will return to the zero position.
Then the instrument will automatically get turned off.

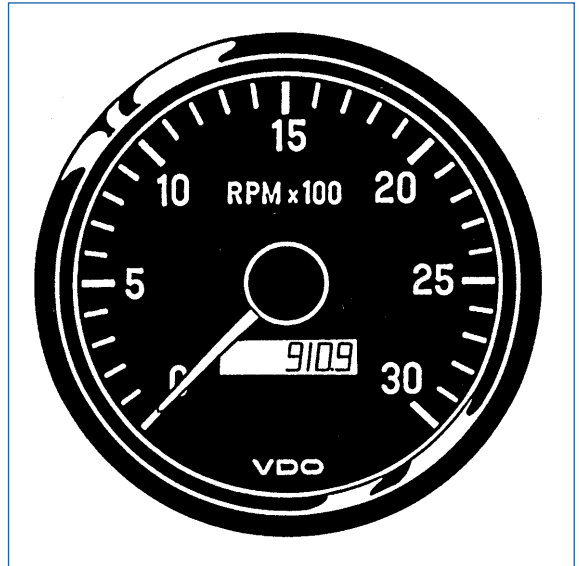

Operating hours display

The display shows operating hours up to '999999.9' max..
This display cannot be adjusted.

Operating hours remain stored after the operating voltage is switched off.

Technical Product Manual

VDO cockpit vision VDO cockpit international

4. Electronic Tachometer With Operating Hours Counter (dia. 80 mm / dia.100 mm) only for VDO cockpit international

4.7 Testing Instructions

- Test accessories**
- 1x Power supply
 - 1x Test cable No. 2
 - 1x Measuring cable
 - 1x Frequency generator
 - 1x Ammeter
- } contained in test cables kit X12-019-101-001
- 1x Wire for pin 5 of the test cable No. 2 (see chapter 18.2.5)

Connector pin allocation

1	2	3	4
5	6	7	8

- Pin 3 Ground
- Pin 4 +10 V to + 31 V
- Pin 5* Permanent positive pole 12 V / 24 V
- Pin 8 Sensor signal input

Test circuit diagram

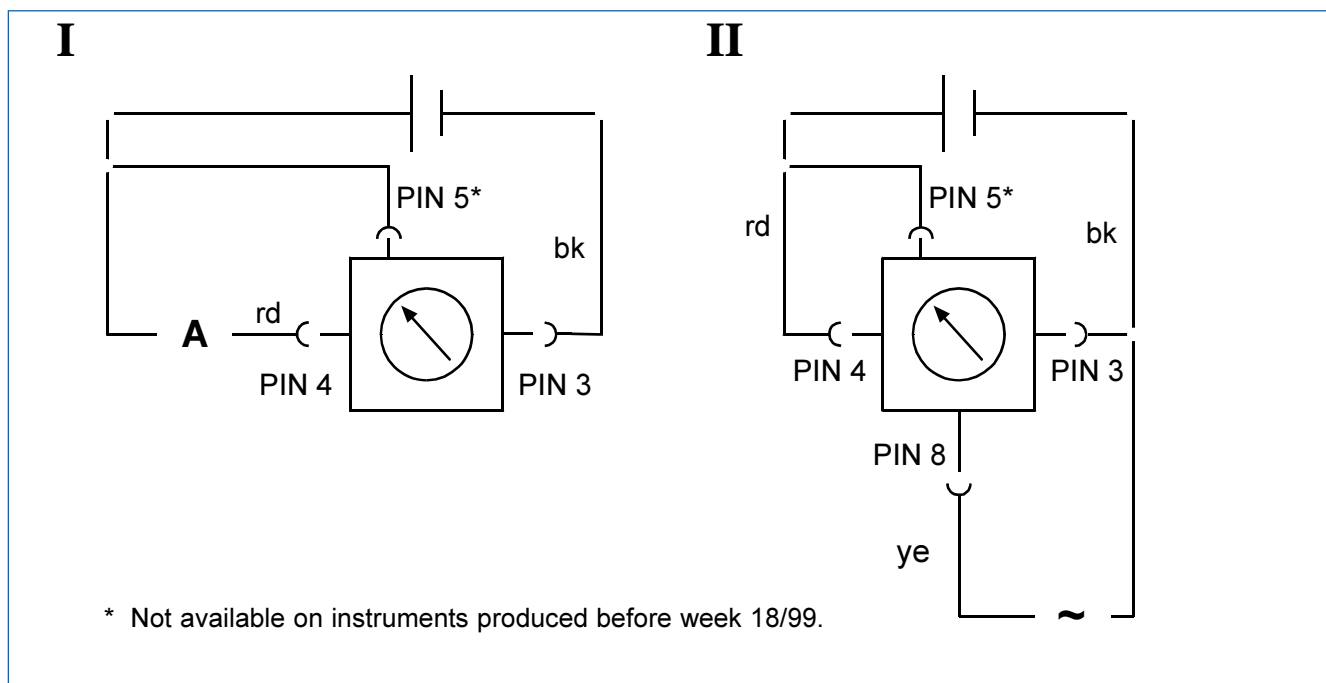

Test method description

Basic setting:	12 V to 24 V instruments	»»»»»	U = 18 V ± 2 V
	strokes + cylinders	»»»»»	4 - 4 C
	function 'A'	»»»»»	A 0.0

Current consumption measurement

Connect the instrument per test circuit diagram II with test cable No. 2.

Value range: 12V to 24 V instruments »»»»» I = 52 ± 5.2 mA

Technical Product Manual

VDO cockpit vision VDO cockpit international

4. Electronic Tachometer With Operating Hours Counter (dia. 80 mm / dia.100 mm) only for VDO cockpit international

4.7 Testing Instructions

Operating hours counter test

Connect instrument with test cable No. 2 as shown in test circuit diagram II.

After connection of the operating voltage the display shows the operating hours. After connection of the engine speed signal of the operating hours are counted and the engine speed is displayed.

The comma flashes with a 1Hz frequency at speeds exceeding 400 rpm.



It is only possible to reset the operating hours with software (see chapter 18.2.6).

Pointer position test

a) Zero point test

Connect instrument with test cable No. 2 as shown in test circuit diagram I.

Connect the operating voltage and check pointer deviation. The allowed deviation is ± 1 degree of angle.

b) Full scale indication test

Connect instrument with test cable No. 2 as shown in test circuit diagram II.

Connect a square wave signal to connector pin 4. The frequency can be calculated with the following formula, the amplitude being between 1 V and 10 V.

Formula for number of pulses per revolution:

$$\left(\frac{\text{pulses}}{\text{revolution}} \right) = \frac{2 \times \text{number of cylinders}}{\text{stroke type} \times \text{number of ignition coil}}$$

Formula for the frequency:

$$f_{\max} = \frac{\left(\frac{\text{pulses}}{\text{revolution}} \right) \times \text{full-scale value}}{60} \text{ [Hz]}$$

Example:

Tachometer with 3000 rpm full-scale, 4 cylinders, four-stroke, 1 ignition coil.

$$\frac{\text{pulses}}{\text{revolution}} = \frac{2 \times 4}{4 \times 1} = 2$$

$$f_{\max} = \frac{2 \times 3000}{60} = 100 \text{ Hz}$$

Technical Product Manual

VDO cockpit vision VDO cockpit international

4. Electronic Tachometer With Operating Hours Counter (dia. 80 mm / dia.100 mm) only for VDO cockpit international

4.8 Instruments Survey

VDO cockpit international (Floodlight) dia. 80 mm

Part No. 333-035-. . .

Dial		Special feature	Part No.
Range	Imprint		
0 ... 3000 min ⁻¹	RPM x 100	12 V - 24 V, dia. 80 mm 12 V illumination	010C 010G
0 ... 4000 min ⁻¹	RPM x 100	12 V - 24 V, dia. 80 mm 12 V illumination	011C 011G
0 ... 6000 min ⁻¹	RPM x 100	12 V - 24 V, dia. 80 mm 12 V ill., with warning contact	014C

VDO cockpit international (Floodlight) dia. 100 mm

Part No. 333-055-. . .

Dial		Special feature	Part No.
Range	Imprint		
0 ... 3000 min ⁻¹	RPM x 100	12 V - 24 V, dia.100 mm 12 V illumination	002C 002G
0 ... 3000 min ⁻¹	RPM x 100 23 - 30 red warning field	12 V - 24 V, dia.100 mm 24 V illumination	004C
0 ... 3000 min ⁻¹	RPM x 100 25 - 30 red warning field	12 V - 24 V, dia.100 mm 24 V illumination	010C

Technical Product Manual

VDO cockpit vision VDO cockpit international

5. Electronic Tachometer (dia 52 mm)

Contents	Page
5.1 General informations	5 - 2
5.2 Technical data	5 - 4
5.3 Pulsing	5 - 6
5.4 Wiring diagram	5 - 7
5.5 Dropping resistor for 24 V	5 - 8
5.6 Setting	5 - 9
5.7 Testing instructions	5 - 14
5.8 Instruments survey	5 - 16

Installation instructions

999-165-005: VDO cockpit vision
999-165-011: VDO cockpit international

See file 'Installation Instructions (MA)'.

Technical Product Manual

VDO cockpit vision VDO cockpit international

5. Electronic Tachometer (dia 52 mm)

5.1 General Informations

The electronic tachometer has been designed for land-bound vehicles only (with the exception of motorcycles).

The instrument has an analog engine speed display in RPM x 100.

The instrument is pulsed by terminal 1 of the ignition coil in the case of petrol engines (4, 6, 8 cylinders, four-stroke), by terminal W of the alternator in the case of diesel engines.

The instrument is set by 3 coding switches at the back of the instrument and a potentiometer on the side of the instrument housing.

The lamp socket is pushed in. To replace the light bulb simple pull the lamp holder out.

Technical Product Manual

VDO cockpit vision VDO cockpit international

5. Electronic Tachometer (dia 52 mm)

5.1 General Informations

Designation of function

Movement: System Ke (to 320°)

(Turning magnet ratio measuring movement, pointer deflection up to 320°)

A turning magnet ratio measuring movement is the main component of the tachometer. It converts the current pulses from the sensor to an analog display on a dial. An electronic circuit converts varying current pulses to unified pulses, which are fed to the turning magnet movement. The turning magnet ratio measuring movement applies the principle of the current ratio of two separate coils. Two stationary coils generate a magnetic field as a function of the current flowing through them. The magnetic field resulting from these two fields moves a two-pole magnet disc carrying a pointer. The pointer deflection is a function of the ratio of the two currents flowing through the coils.

A shielding casing prevents the effect of external magnetic fields.

The special electronic system controlling the movement permits a pointer deflection of 320°. The rotation is limited by a pin on the turning magnet moving in a groove of the coil carrier; the opposing force is generated by a spiral spring.

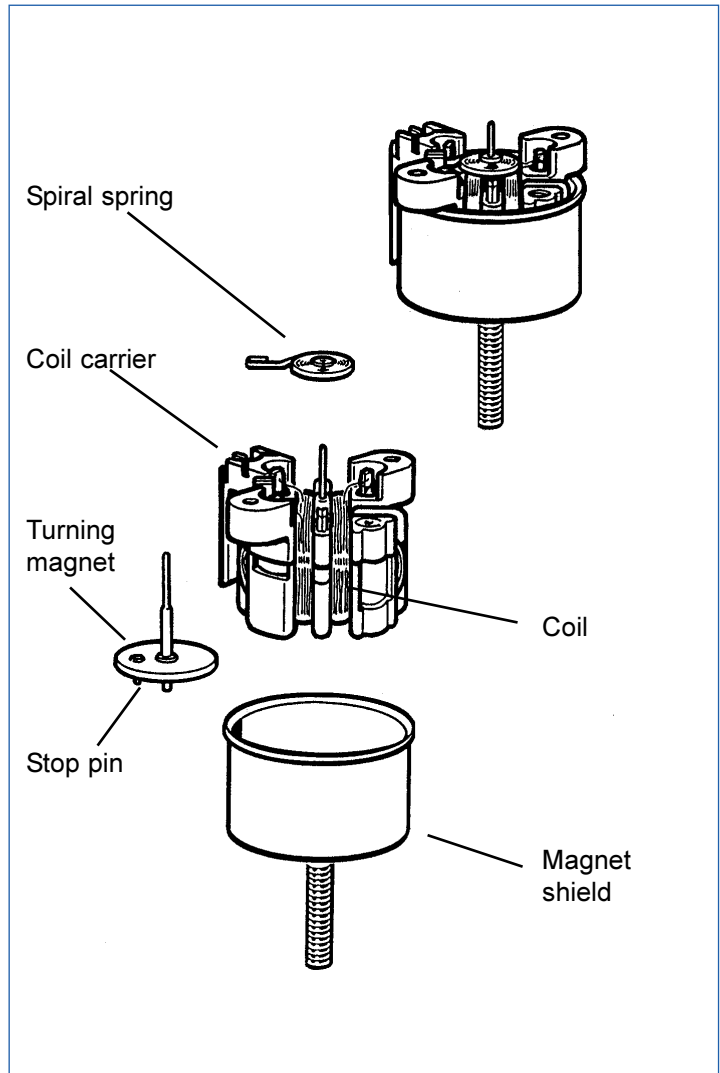

Technical Product Manual

VDO cockpit vision VDO cockpit international

5. Electronic Tachometer (dia 52 mm)

5.2 Technical Data

Operating voltage:	10.8 ... 16 V
Input signal voltage:	U_{low} : max. 5 V U_{high} : min. 7.5 V
Movement:	System Ke (. 320°)
Pickup:	terminal 1 ignition coil (petrol engine) terminal W alternator (diesel engine)
Current consumption:	< 100 mA (without illumination)
Operating temp.:	- 20°C ... + 70°C
Storage temperature:	- 30°C ... + 85°C
Illumination:	1 light bulb 12 V, 1. 2 W 2 colour caps (green and red)
Protection:	IP64 DIN 40050 from the front, housing 'ozon' proof 'UV' proof CE approved, reverse-polarity protection
Vibration resistance:	max. 1g eff., 25 ... 500 Hz, duration 8h, f. 1 octave/min.
Nominal position:	NL 0 to NL 90, DIN 16257

VDO cockpit vision
dia. 52 mm Backlight

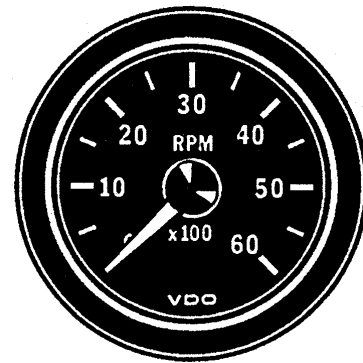

6 ... 25 pulses/revolution
(adjustable)

Mounting hole: dia. 53mm

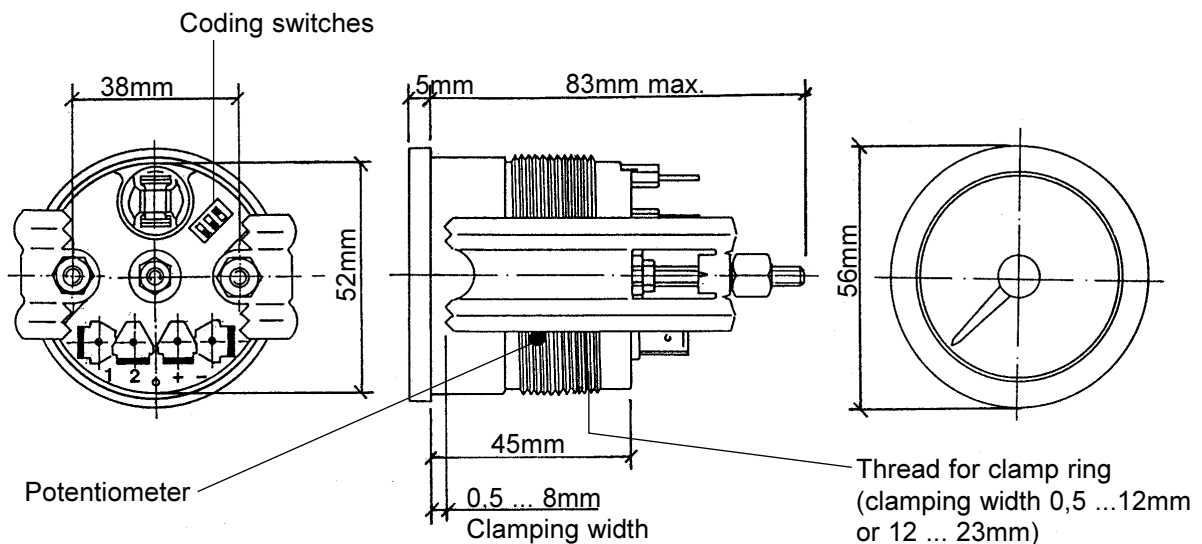

Pin assignment:

- Pin +: +12 V, terminal 15
- Pin -: Ground, terminal 31
- Pin 2: Signal input, terminal 1 or W

- Option:**
- dropping resistor for 24 V with light bulb 24 V, 1.2 W (operating voltage: 21 ... 32 V)

Technical Product Manual

VDO cockpit vision VDO cockpit international

5. Electronic Tachometer (dia 52 mm)

5.2 Technical Data

Operating voltage:	10.8 ... 16 V
Input signal voltage:	U_{low} : max. 5 V U_{high} : min. 7.5 V
Movement:	System Ke (. 320°)
Pickup:	terminal 1 ignition coil (petrol engine) terminal W alternator (diesel engine)
Current consumption:	< 100 mA (without illumination)
Operating temp.:	- 20°C ... + 70°C
Storage temperature:	- 30°C ... + 85°C
Illumination:	1 light bulb 12 V, 2 W
Protection:	IP64 DIN 40050 from the front, housing 'ozon' proof, 'UV' proof, CE approved, reverse-polarity protection
Vibration resistance:	max. 1g eff., 25 ... 500 Hz, duration 8h, f. 1 octave/min.
Nominal position:	NL 0 to NL 90, DIN 16257

VDO cockpit international
dia.Ø 52 mm Floodlight

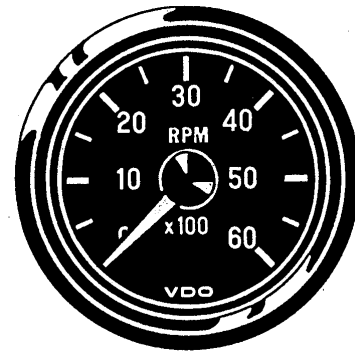

6 ... 25 pulses/revolution
(adjustable)

Mounting hole: dia. 53mm

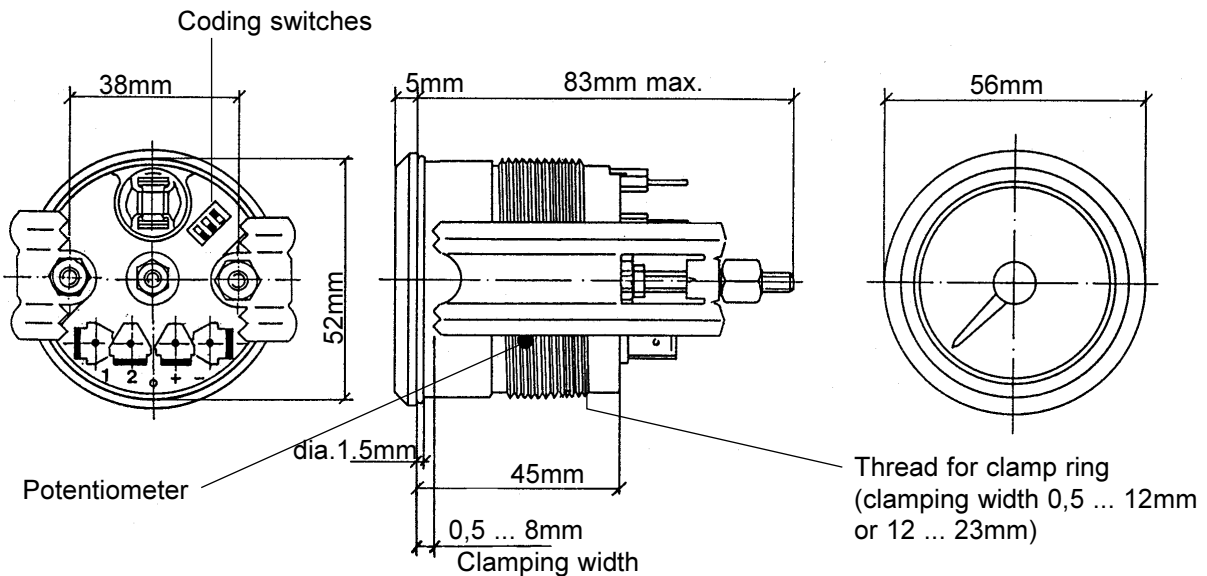

Pin assignment:

Pin +: +12 V, terminal 15
Pin -: Ground, terminal 31
Pin 2: Signal input,
terminal 1 or W

Option:

dropping resistor for 24 V
with light bulb 24 V 1.2 W
(operating voltage 21 ... 32 V)

Technical Product Manual

VDO cockpit vision VDO cockpit international

5. Electronic Tachometer (dia 52 mm)

5.3 Pulsing

Tachometer connection at pin 2.

In vehicles with petrol engines the pulse is obtained at terminal 1 of the ignition coil in the case of conventional ignition systems (having one coil only) or an additional terminal on special ignition systems.

In the case of special ignition systems (such as transistor/coil ignition systems, electronic and fully electronic ignitions) please consult the vehicle manufacturer or the ignition system manufacturer about the correct terminal.

Conventional ignition system

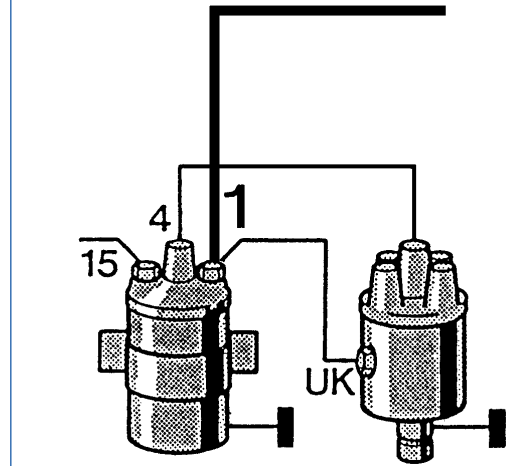

The pulse on vehicles with diesel engines is obtained at alternator terminal W.

Alternator

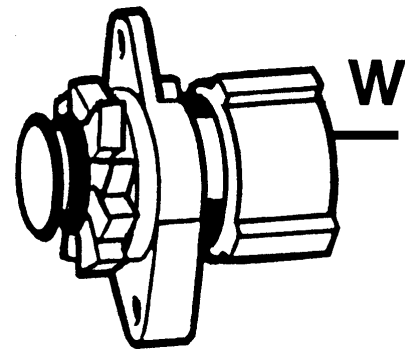

The ignition must be off and the battery minus connection disconnected when connecting the cable.

Technical Product Manual

VDO cockpit vision VDO cockpit international

5. Electronic Tachometer (dia 52 mm)

5.4 Wiring Diagram

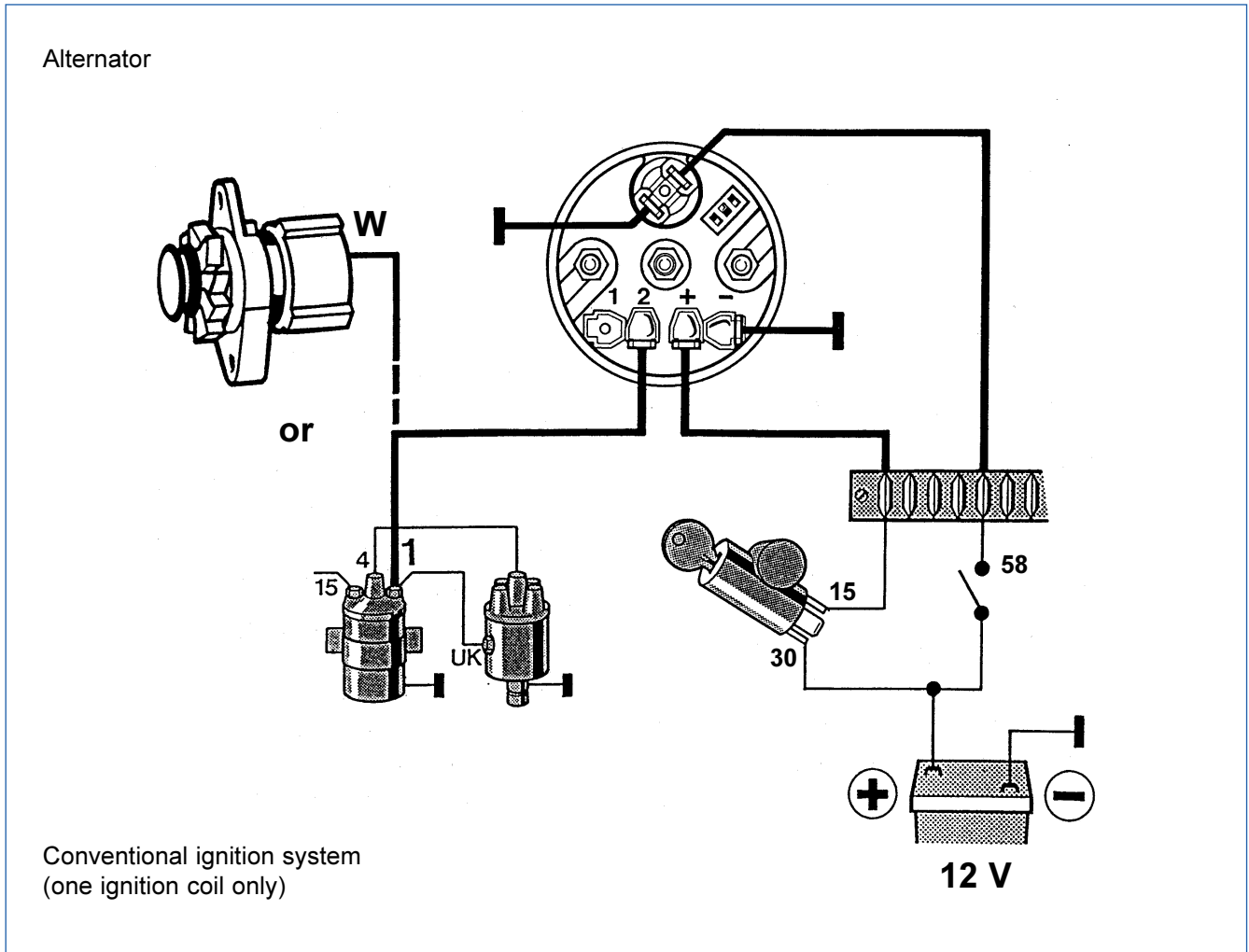

Technical Product Manual

VDO cockpit vision VDO cockpit international

5. Electronic Tachometer (dia 52 mm)

5.5 Dropping Resistor For 24 V

The electronic tachometer (nominal voltage 12V) can also be used with a nominal voltage of 24V if an external dropping resistor (option) is installed in the plus line (terminal 15).

Connect this dropping resistor directly to pin + of the instrument, then connect it to the plus line (terminal 15).

In this case the operating voltage range is 21V to 32V.



Replace 12V light bulb by 24V light bulb.

VDO cockpit vision:

Dropping resistor with 24 V 1.2 W light bulb.
Part No.: 800-005-011G

VDO cockpit international:

Dropping resistor with 24 V 2 W light bulb.
Part No.: 800-005-027G

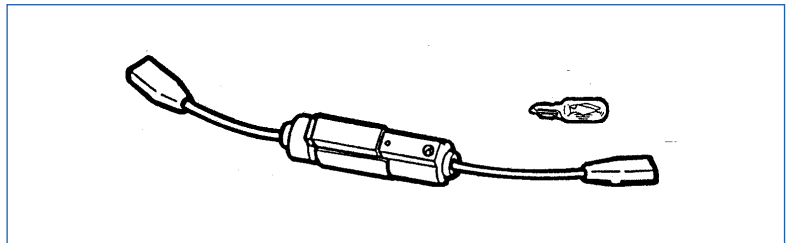

Wiring diagram

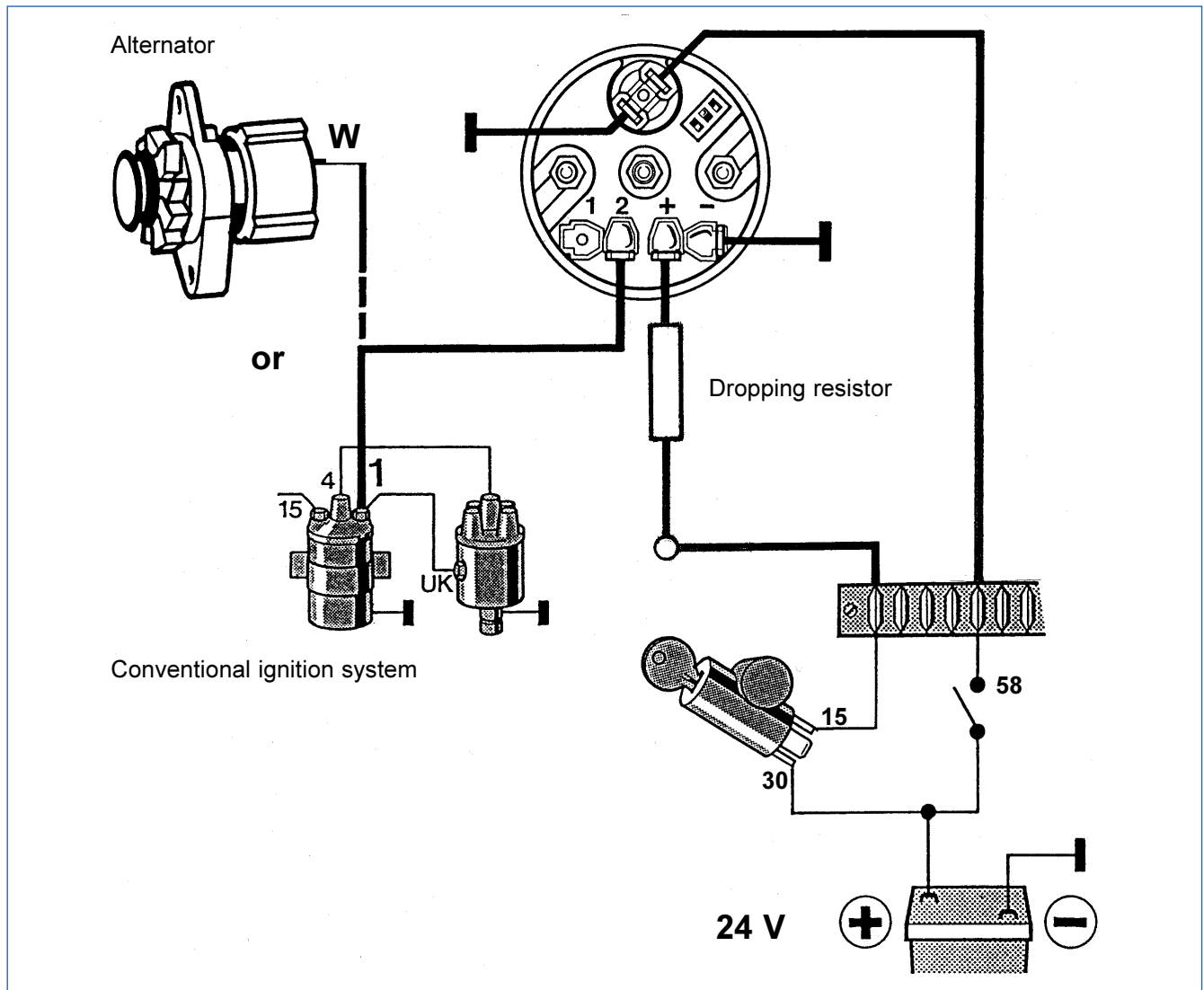

Technical Product Manual

VDO cockpit vision VDO cockpit international

5. Electronic Tachometer (dia 52 mm)

5.6 Setting

The electronic tachometer is adjusted at the back of the instrument by 3 coding switches and a potentiometer on the side of the instrument housing.

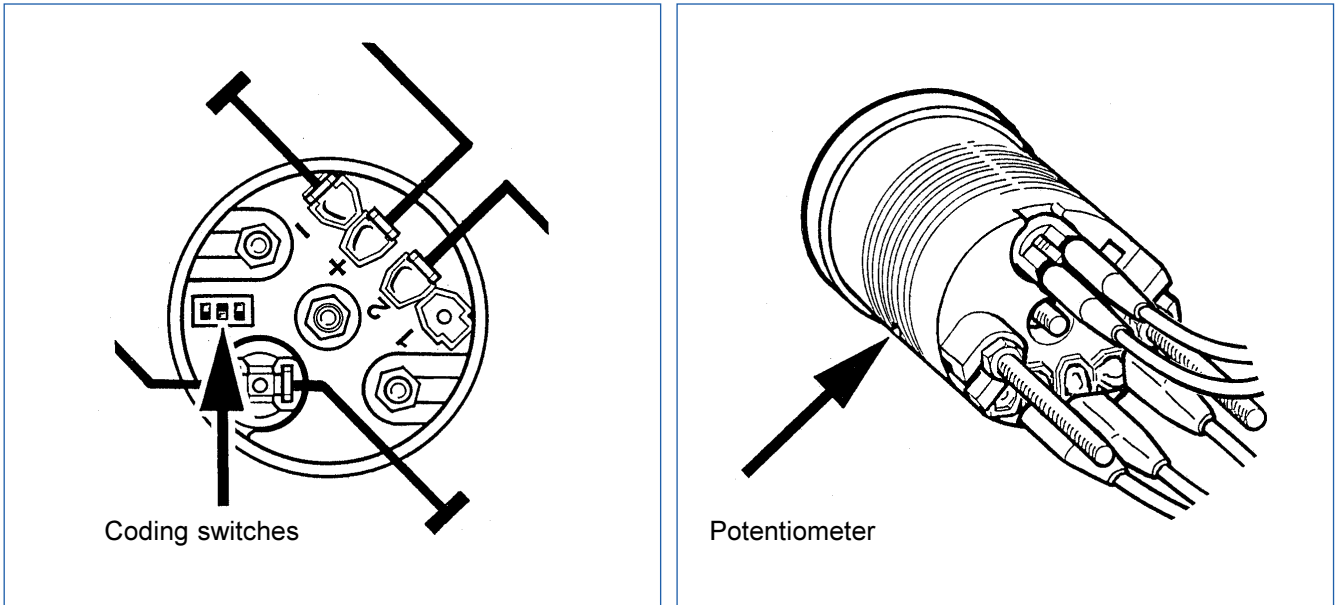

Petrol engine setting

For petrol engines (4, 5, 6 or 8 cylinders) and connection to terminal 1 (only one ignition coil) either only use the coding switches for setting or use the coding switches (coarse setting) and use the potentiometer (fine adjustment) for setting. Possible settings per coding table (see page 5 - 10).

Diesel engine setting

For the diesel engine and connection to terminal W of the alternator use the coding switches (coarse setting) and the potentiometer (fine adjustment) for setting.

Roughly set the pulse ratio (pulses at the terminal W output of the alternator for one engine revolution) per coding table (see page 5 - 11) with the coding switches. Make the fine adjustment with the potentiometer. Compare the engine speed indication with a reference measuring instrument (hand-held tachometer) (see page 5 - 13).

Technical Product Manual

VDO cockpit vision VDO cockpit international

5. Electronic Tachometer (dia 52 mm)

5.6 Setting

Petrol engine setting

Coding table

Petrol engine, terminal 1 (one ignition coil)					Only coding switches	Coding switches and potentiometer
Coding switches			Cylinders	Stroke	⚠ Do not change the potentiometer setting! Changing the potentiometer setting will cause wrong readings.	Use a reference tachometer to set the potentiometer ▼
1	2	3				
on	off	off	4	4	x	
on	off	off	5	4		x
on	off	on	6	4	x	
on	on	off	8	4	x	

▼ The adjustment must be made by two people, one of them adjusting the instrument, the other one using the hand-held tachometer (reference tachometer), see page 5 -13.

Example:
 on, off, off
 (4 cylinders, four-stroke)

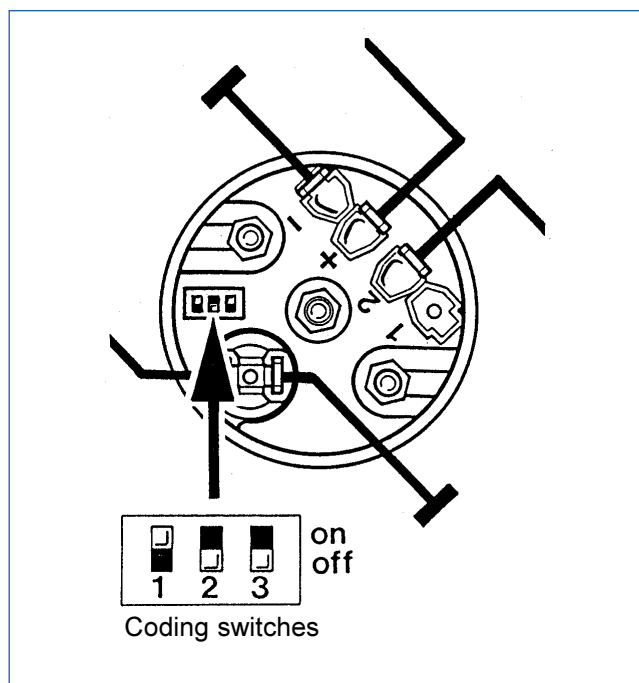

Technical Product Manual

VDO cockpit vision VDO cockpit international

5. Electronic Tachometer (dia 52 mm)

5.6 Setting

Diesel engine setting

Set the coding switches per coding table if the pulse ratio is known (coarse setting).

Coding table

Diesel engine, terminal W					
Switches			RPM		
1	2	3	4000	6000	8000
off	off	off	6 - 9	8 - 12	6 - 9
off	off	on	9 - 13	12- 17	9 - 13
off	on	off	13 - 20	17 - 24	12 - 18
			Pulses per revolution		

Example: off, off, off
(at 6000 RPM 10 pulses per revolution)

on
off

Coding switches

Make the fine adjustment with the potentiometer (see page 5 - 13).

Technical Product Manual

VDO cockpit vision VDO cockpit international

5. Electronic Tachometer (dia 52 mm)

5.6 Setting

Diesel engine setting

The following formula can be used to calculate an unknown pulse ratio, which is then set as described on page 5 - 11.

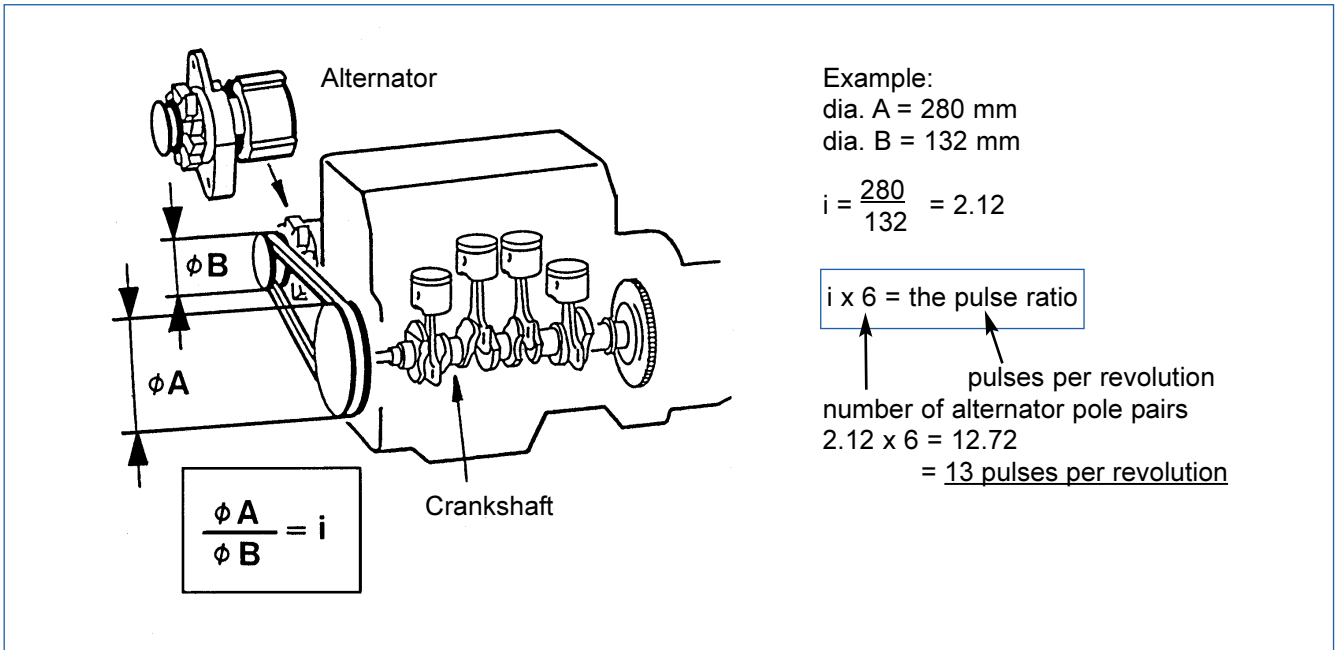

Set the coding switches to 'off, off, off' first if the number of alternator pole pairs is not known. Make the fine adjustment with the potentiometer.

Select a different coding switches position and the potentiometer if the indication cannot be matched to the reference instrument indication.

Calculate the pulse ratio as follows if the frequency (Hz) is known, and not the pulse ratio:

Example 1733 Hz:

$$\frac{\text{Hz} \times 60 \text{ sec.}}{\text{full scale speed}} = \text{pulses/revolution}$$

$$\frac{1733 \times 60}{8000} = 12.99 = 13 \text{ pulses/revolution}$$

Formula for frequency (Hz):

Example:

$$\frac{\text{pulses/revolution} \times \text{full scale speed}}{60 \text{ sec.}} = \text{Hz}$$

$$\frac{13 \times 8000}{60} = 1733 \text{ Hz}$$

Technical Product Manual

VDO cockpit vision VDO cockpit international

5. Electronic Tachometer (dia 52 mm)

5.6 Setting

Diesel engine setting

Fine adjustment with potentiometer

The fine adjustment using the potentiometer is only possible between 30% and 100% of the indicating range. Use a reference tachometer (hand-held tachometer) to compare the engine speed indications.

The adjustment must be made by two people, one of them adjusting the instrument, the other one using the hand-held tachometer.

Measure the engine speed at the crankshaft stub of the engine with the hand-held tachometer.

Be very careful! Do not wear loose clothing!

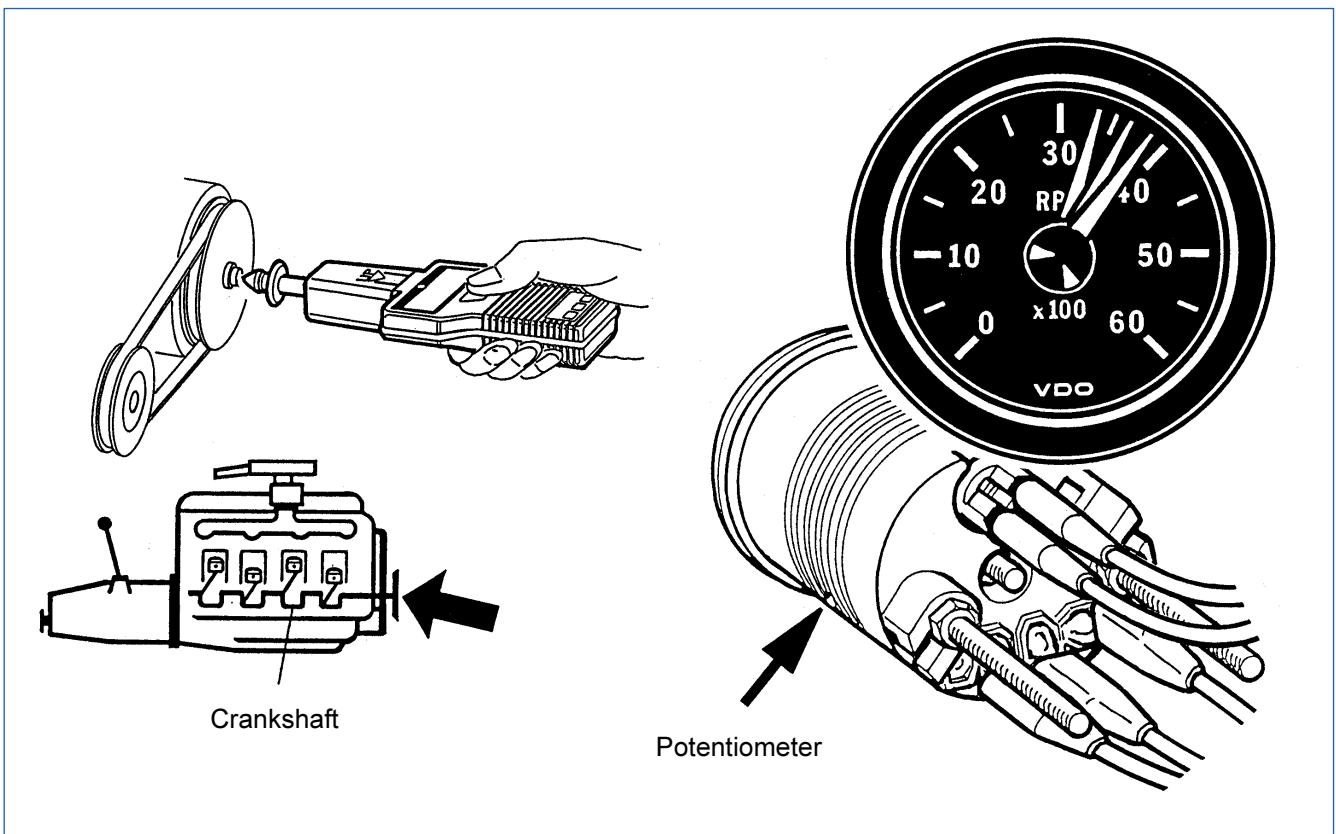

Adjust potentiometer with an insulated screwdriver to speed indication matches the indication of the hand-held tachometer.

Technical Product Manual

VDO cockpit vision VDO cockpit international

5. Electronic Tachometer (dia 52 mm)

5.7 Testing Instructions

Test accessories

- 1x Power supply
- 1x Test cable No. 3 } contained in test cables kit
- 1x Measuring cable } X12-019-101-001
- 1x Frequency generator
- 1x Ammeter

Pin allocation

- Pin + + 12V
- Pin - Ground
- Pin 2 Sensor signal input

Test circuit diagram

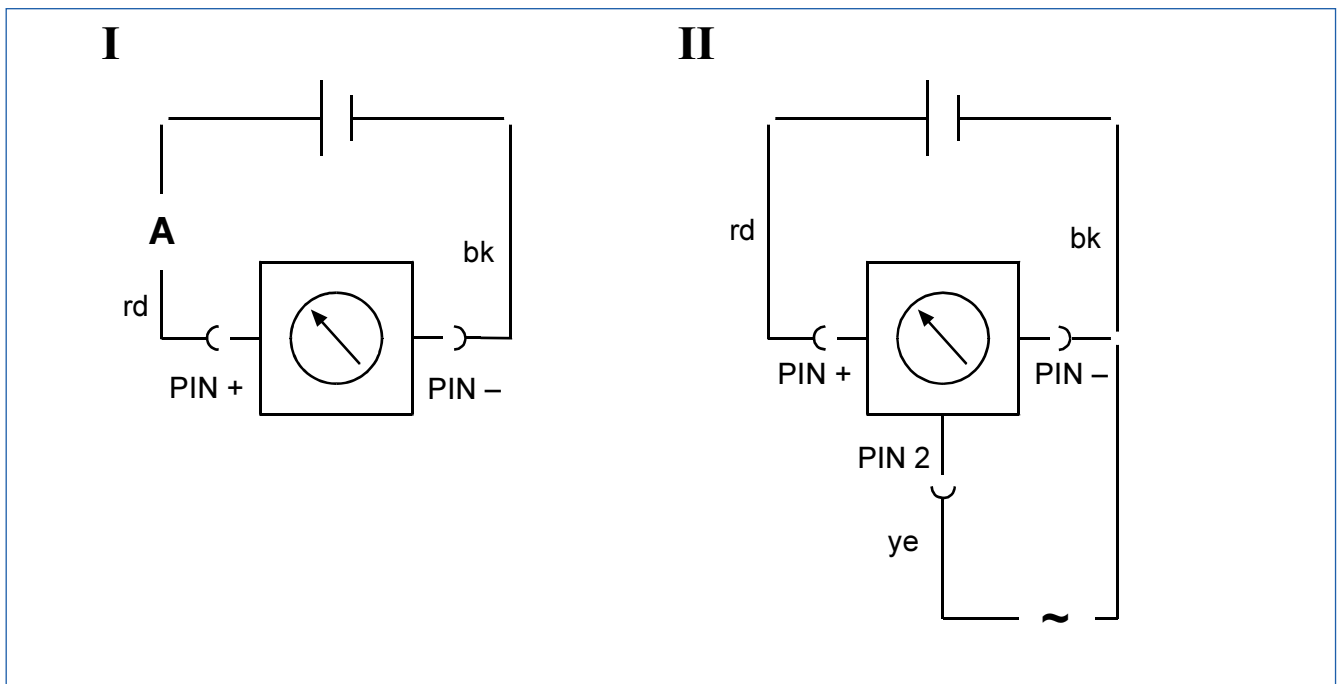

Technical Product Manual

VDO cockpit vision VDO cockpit international

5. Electronic Tachometer (dia 52 mm)

5.7 Testing Instructions

Test method description

Basic setting: 12 V instruments  14 V ± 0.2 V

Set coding switches (at instrument back) to: 1-on, 2-off, 3-off .

Current consumption measurement

Connect the instrument per test circuit diagram I with test cable No. 3.

Value range: 12 V instruments  I = 69 ± 10 mA

Pointer position check

a) Zero position check

Connect the instrument per test circuit diagram I with test cable No. 3.

Switch operating voltage on and check pointer deviation. The allowed deviation is ± 2 angular degrees.

b) Full range position check

Connect the instrument per test circuit diagram II with test cable No. 3.

Connect a square wave signal with a frequency corresponding to full range to pin 2. The amplitude shall be at least 10 V.

Engine speed range	Frequency	Tolerance
6000 RPM	200 Hz	± 150 RPM
8000 RPM	267 Hz	± 200 RPM

Technical Product Manual

VDO cockpit vision VDO cockpit international

5. Electronic Tachometer (dia 52 mm)

5.8 Instruments Survey

VDO cockpit vision (Backlight) dia. 52 mm

Part No. 333-015-...

Dial		Special feature	Part No.
Range	Imprint		
0 ... 6000 min ⁻¹	RPM x 100	12 V	009K
0 ... 8000 min ⁻¹	RPM x 100	12 V	010K

VDO cockpit international (Floodlight) dia. 52 mm

Part No. 333-035-...

Dial		Special feature	Part No.
Range	Imprint		
0 ... 6000 min ⁻¹	RPM x 100	12 V	017C 017G
0 ... 8000 min ⁻¹	RPM x 100	12 V	018G
0 ... 4000 min ⁻¹	RPM x 100	12 V with helical gear ring with stud bolt	029C 029G

Technical Product Manual

VDO cockpit vision VDO cockpit international

6. Electric Pressure Gauge (dia. 52 mm)

Contents	Page
6.1 General informations	6 - 2
6.2 Technical data	6 - 4
6.3 Pressure sensors	6 - 6
6.4 Wiring diagrams	6 - 12
6.5 Testing instructions	6 - 13
6.6 Instruments survey	6 - 15

Installation instructions

999-161-011: VDO cockpit vision
999-161-003: VDO cockpit international

See file 'Installation Instructions (MA)'.

Technical Product Manual

VDO cockpit vision VDO cockpit international

6. Electric Pressure Gauge (dia. 52 mm)

6.1 General Informations

The electric pressure gauge has been designed for land-bound vehicles or stationary systems only (exception: motorcycles).

The instrument has an analog pressure display graduated in bar or kPa.

Pressure sensors of the following types, adapted to the indicator pressure range, can be used:

negative earth,
insulated earth,
negative earth with warning contact.



The lamp socket is clipped in.
To replace the light bulb, carefully, with the thumb,
push the lamp holder out to the side.

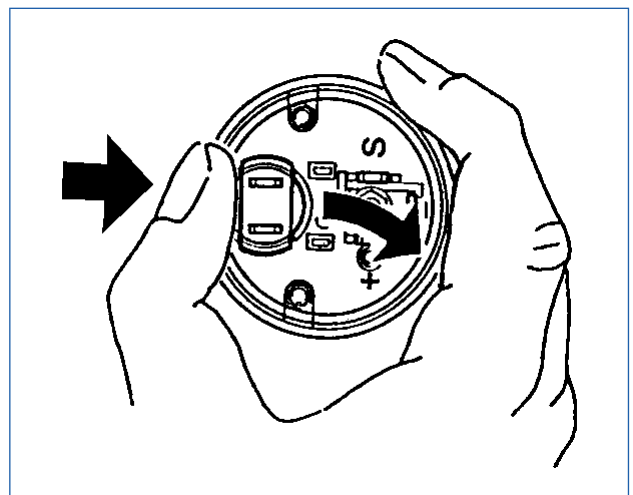

Technical Product Manual

VDO cockpit vision VDO cockpit international

6. Electric Pressure Gauge (dia. 52 mm)

6.1 General Informations

Designation of functions

Movement: System Ke (90°)

(Turning magnet movement for ratio indication, maximum pointer travel 90°)

The pressure indicator applies the resistance measurement principle. A sensor converts the measured pressure to a corresponding resistance value. A turning magnet ratio measuring movement measures this resistance value. This value is displayed by a pointer moving over a dial graduated in pressure units. The turning magnet movement for ratio measurement comprises three stationary coils wound at 90° against each other, and a rotating permanent magnet disk in these coils. The coils are connected in a circuit for ratio measurement, so that the instrument is insensitive to on-board voltage fluctuations.

This means that the pointer travel is only a function of the magnitude of the current flowing through the measuring system.

A magnetic shield prevents effects of external magnetic fields, indication errors due to temperature changes are corrected by a compensating resistor. A dropping resistor is used to adapt the measuring movement to higher operating voltages (e. g. 24V).

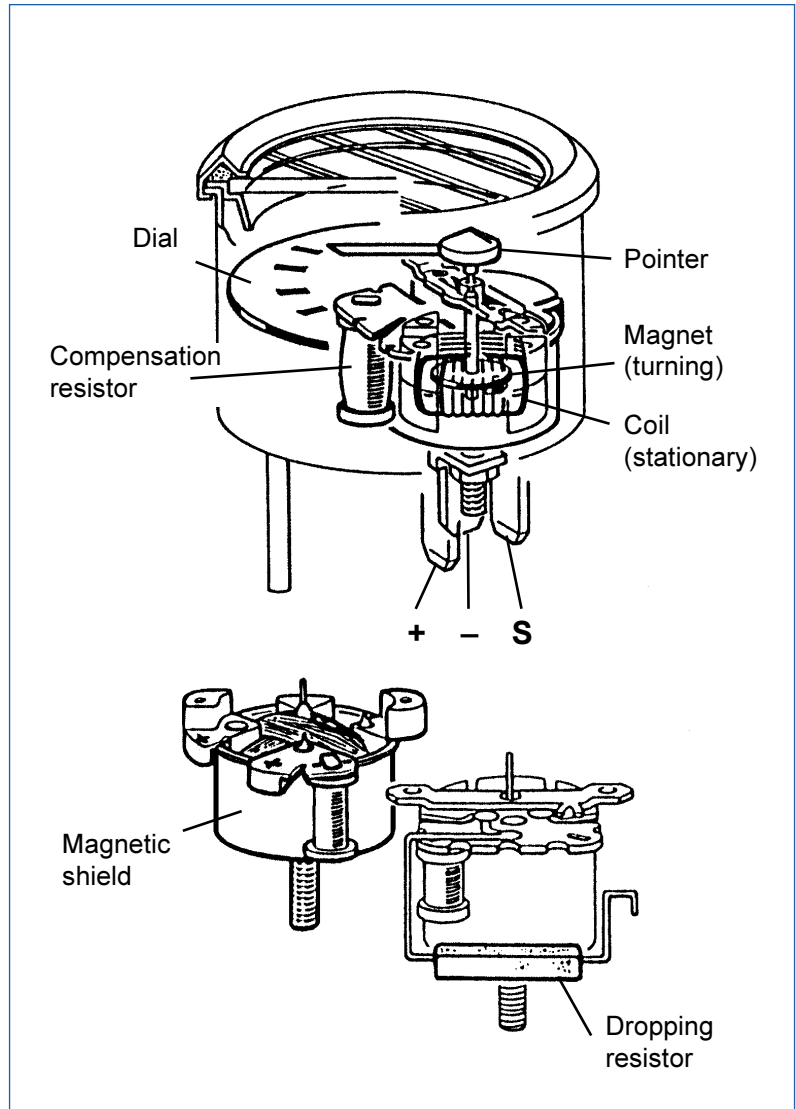

Technical Product Manual

VDO cockpit vision VDO cockpit international

6. Electric Pressure Gauge (dia. 52 mm)

6.2 Technical Data

Operating voltage:	11 ... 16 V or 21.5 ... 30 V
Movement:	System Ke (90°)
Current consumption:	82 mA (without illumination)
Operating temp.:	- 30°C ... + 85°C
Storage temperature:	- 40°C ... + 90°C
Illumination:	1 light bulb 14 V, 3.4 W or 24 V, 3 W, 2 colour caps (only at 12 V)
Protection:	IP64 DIN 40050 from the front reverse-polarity protection
Vibration resistance:	max. 1g eff., 25 ... 2000 Hz, duration 8h, f: 1 octave/min.
Nominal position:	NL 0 to NL 90, DIN 16257

VDO cockpit vision
dia. 52 mm Backlight



Mounting hole: dia.53mm

Sensor:
pressure sensor (diaphragm),
not included.

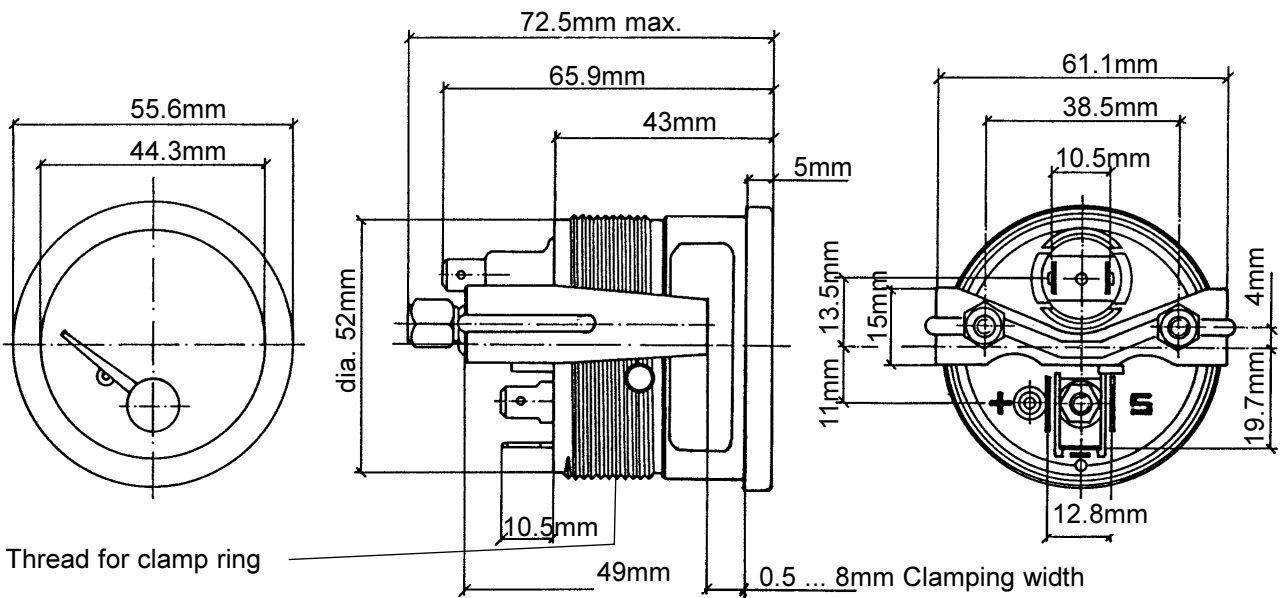

Thread for clamp ring

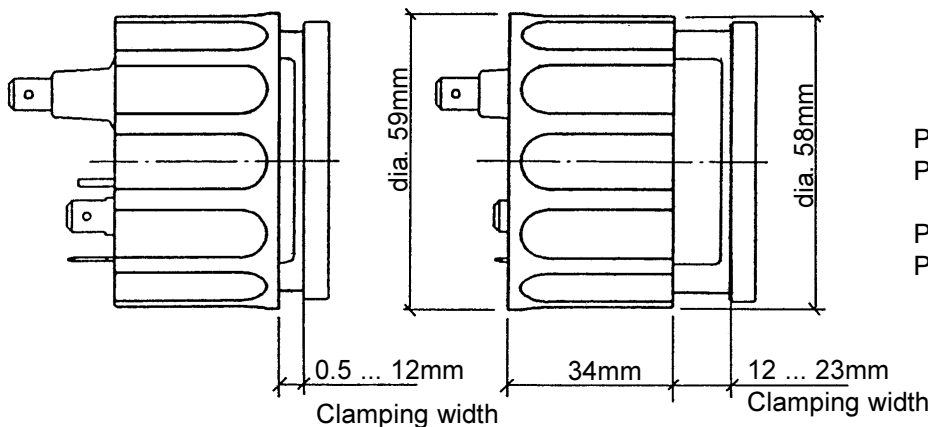

Pin assignment:
Pin +: + 12 V or + 24 V,
terminal 15
Pin -: Ground, terminal 31
Pin S: Sensor

Technical Product Manual

VDO cockpit vision VDO cockpit international

6. Electric Pressure Gauge (dia. 52 mm)

6.2 Technical Data

Operating voltage:	11 ... 16 V or 21.5 ... 30 V
Movement:	System Ke (90°)
Current consumption:	82 mA (without illumination)
Operating temp.:	- 30°C ... + 85°C
Storage temperature:	- 40°C ... + 90°C
illumination:	1 light bulb 14 V, 3.4 W or 24 V, 3 W
Protection:	IP64 DIN40 050 from the front reverse-polarity protection
Vibration resistance:	max. 1g eff., 25 ... 2000 Hz, duration 8h, f. 1 octave/min.
Nominal position:	NL 0 to NL 90, DIN 16257

VDO cockpit international
dia. 52 mm Floodlight



Mounting hole: dia. 53mm

Sensor:
pressure sensor (diaphragm),
not included.

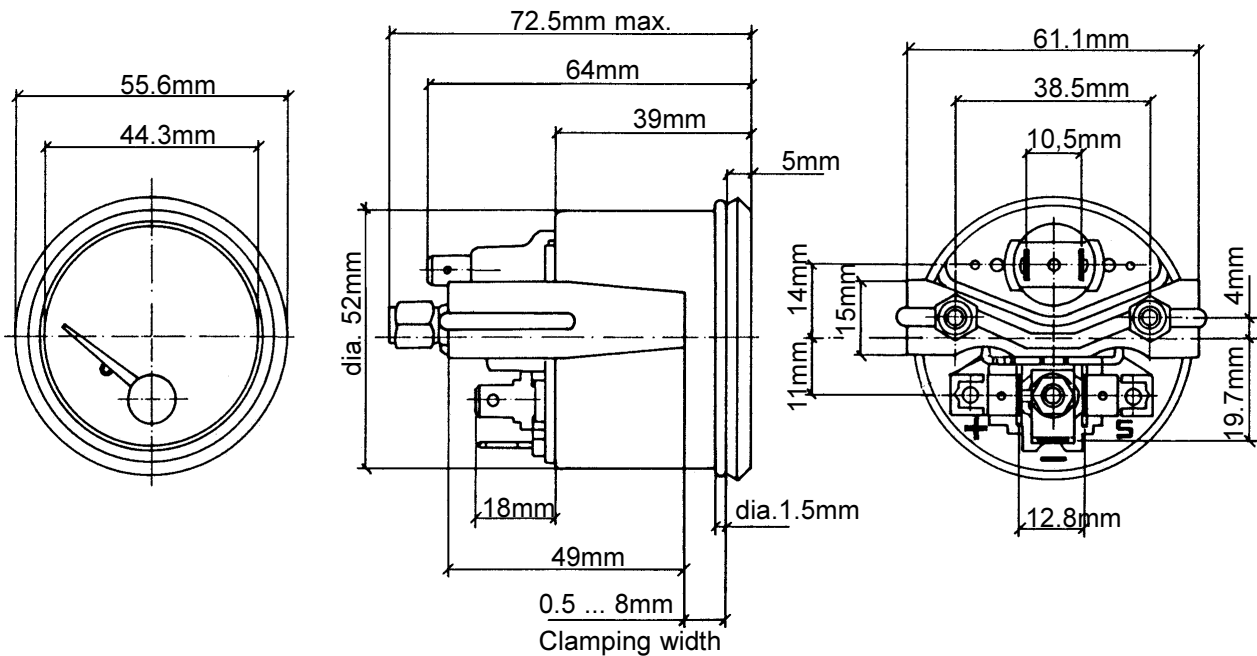

Pin assignment:

Pin +: + 12 V or + 24 V,
terminal 15

Pin -: Ground, terminal 31

Pin S: Sensor

Technical Product Manual

VDO cockpit vision VDO cockpit international

6. Electric Pressure Gauge (dia. 52 mm)

6.3 Pressure Sensors

The pressure sensors needed to operate the instrument is not included with the instrument.

The following pressure sensors (see data sheets for sensors) adapted to the instrument indicating range, can be used:

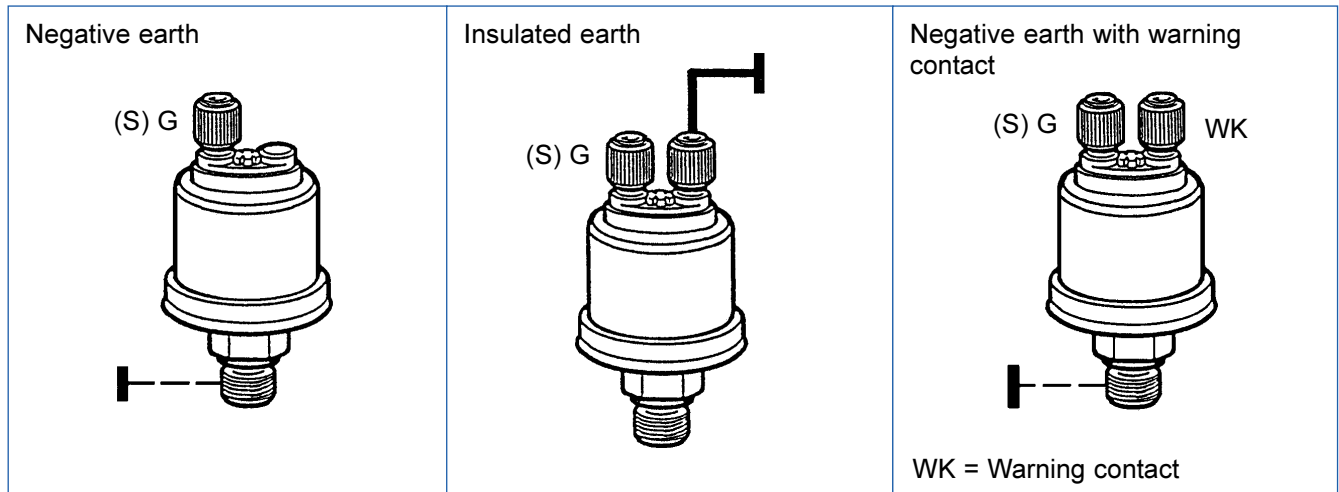

The sensor is installed in the oil circuit at a position specified by the vehicle manufacturer (e.g. oil pressure switch). Use an adequate parts kit if a direct installation is not possible at this location.

To mount the pressure sensor it is absolutely only to use the hexagon nut.

If the connection thread is cylindrical, a sealing washer or a sealing ring made of copper must be fitted.

The values mentioned in the following table for the maximum tightening torque (Nm max.) refer exclusively to the load-bearing capacity of pressure sensors.

 Prior to using the pressure sensor, it is important to ask the manufacturer of the vehicle, equipment system or engine in each instance for the maximum torque [? Nm max.] value for the threaded hole into which the pressure sensor is to be screwed. Non-observance of the maximum thightening torque specified for the threaded hole in each instance can result in damage to the vehicle, engine or equipment system.

Thread	max.
M 10 x 1	30 Nm
1/8 in. BSPF	30 Nm
1/8 - 27 NPTF	30 Nm
R 1/8 DIN 2999	30 Nm
M12 x 1.5	40 Nm
M12 x 1	50 Nm
M14 x 1.5	60 Nm
1/4 in. BSPF	60 Nm
1/4 - 18 NPTF	60 Nm
3/8 - 18 NPTF	60 Nm
M 16 x 1.5	80 Nm
3/8 - 18 Dryseal NPTF	80 Nm
M 18 x 1.5	100 Nm

Technical Product Manual

VDO cockpit vision VDO cockpit international

6. Electric Pressure Gauge (dia. 52 mm)

6.3 Pressure Sensors

Adaptor kits for oil pressure sensors

Adaptor kit with pressure hose

Kit includes: coupling, pressure hose (1000 mm long), adaptor, gasket and 2 screws.

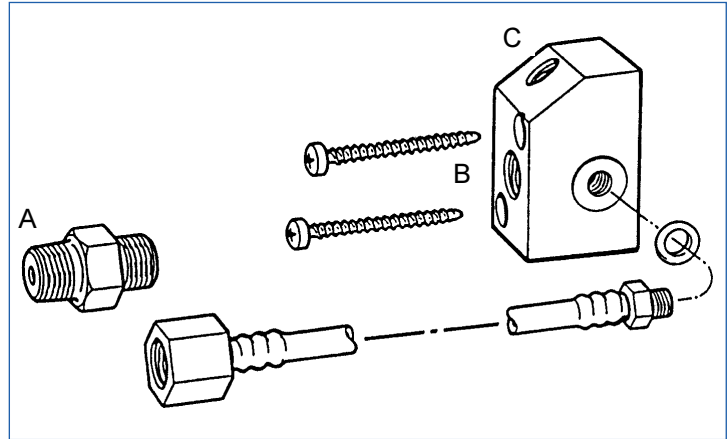

Part No.	Thread A	Thread B	Thread C
X11-360-004-023	M12 x 1.5 con.	M12 x 1.5	M10 x 1
X11-360-004-024	M14 x 1.5 con.	M14 x 1.5	M10 x 1
X11-360-004-025	14 - 18 PTF SEA SHORT	1/4 - 18 NPTF	M10 x 1
X11-360-004-026	R1/8 DIN 2999	R 1/8 DIN 2999	M10 x 1

Ask for the maximum torque (? Nm max.) from the engine manufacturer, equipment manufacturer or car manufacturer.

? Nm max.

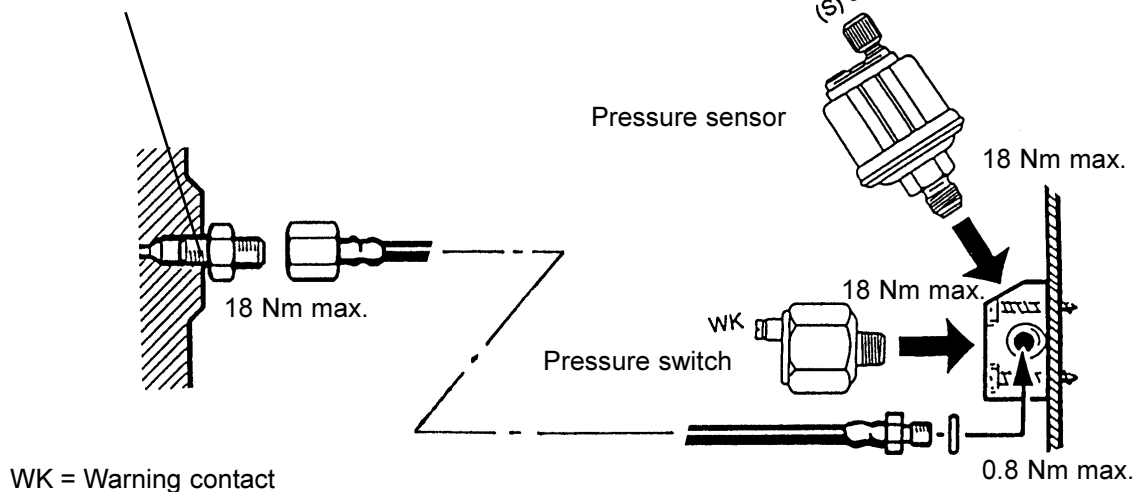

Technical Product Manual

VDO cockpit vision VDO cockpit international

6. Electric Pressure Gauge (dia. 52 mm)

6.3 Pressure Sensors

Adaptor kits for oil pressure sensors

Adaptor kit with 2 connections

Kit includes: hollow screw, adaptor and 2 gaskets

Part No. X11-360-004-020

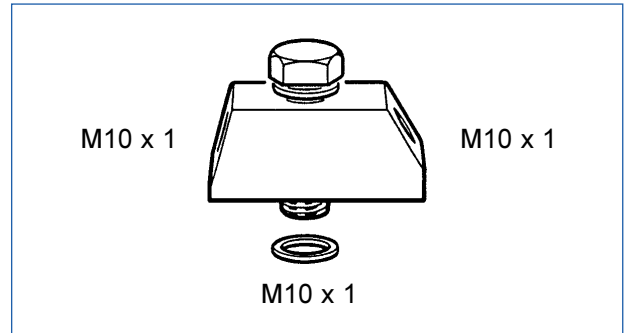

Part No. X11-360-004-021

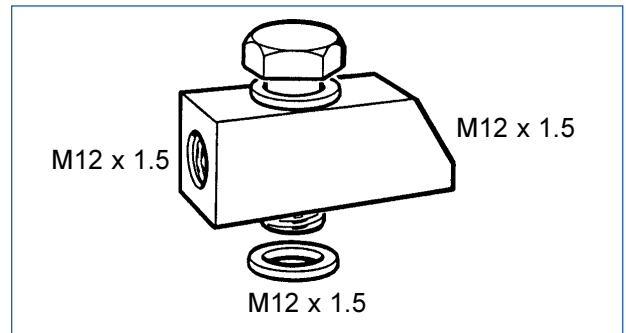

Ask for the maximum torque (? Nm max.) from the engine manufacturer, equipment manufacturer or car manufacturer.

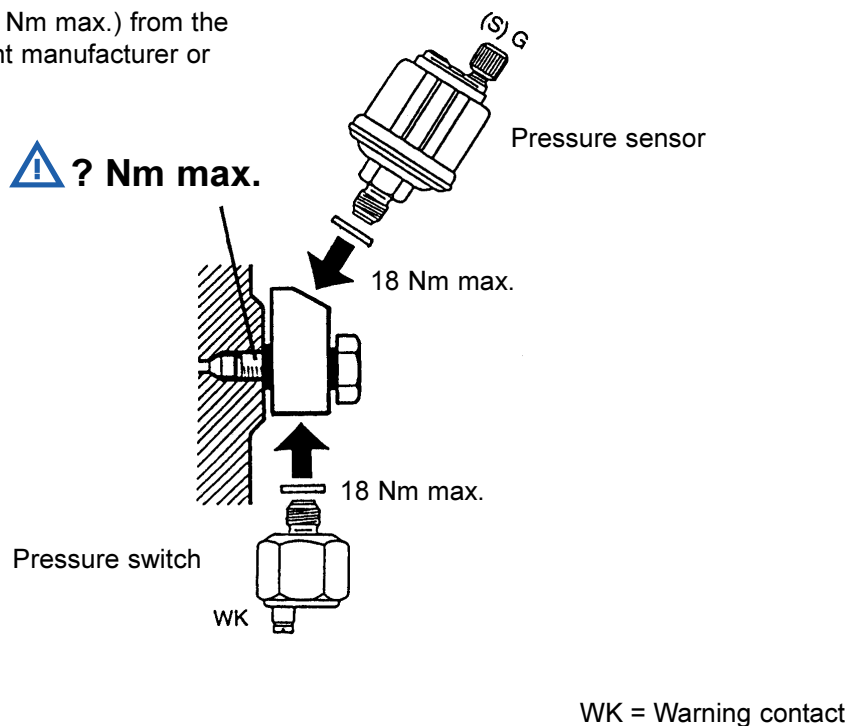

Technical Product Manual

VDO cockpit vision VDO cockpit international

6. Electric Pressure Gauge (dia. 52 mm)

6.3 Pressure Sensors

Adaptor kits for oil pressure sensors

Adaptor kit with 1 connection

Kit includes: hollow screw, adaptor and 2 gaskets

Part No. X11-360-004-005

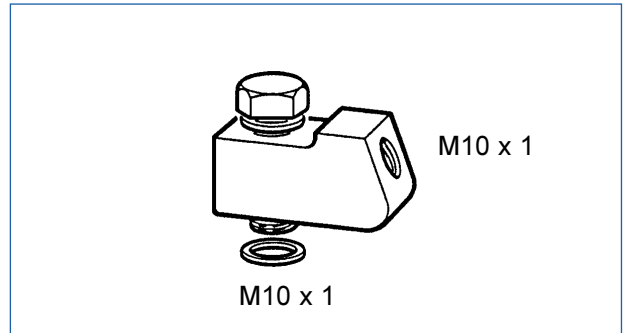

Part No. X11-360-004-027

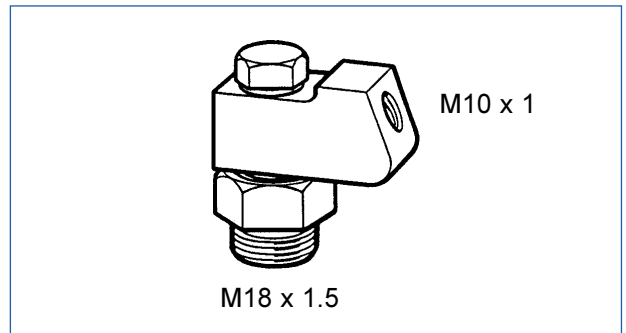

Ask for the maximum torque (? Nm max.) from the engine manufacturer, equipment manufacturer or car manufacturer.

 ? Nm max.

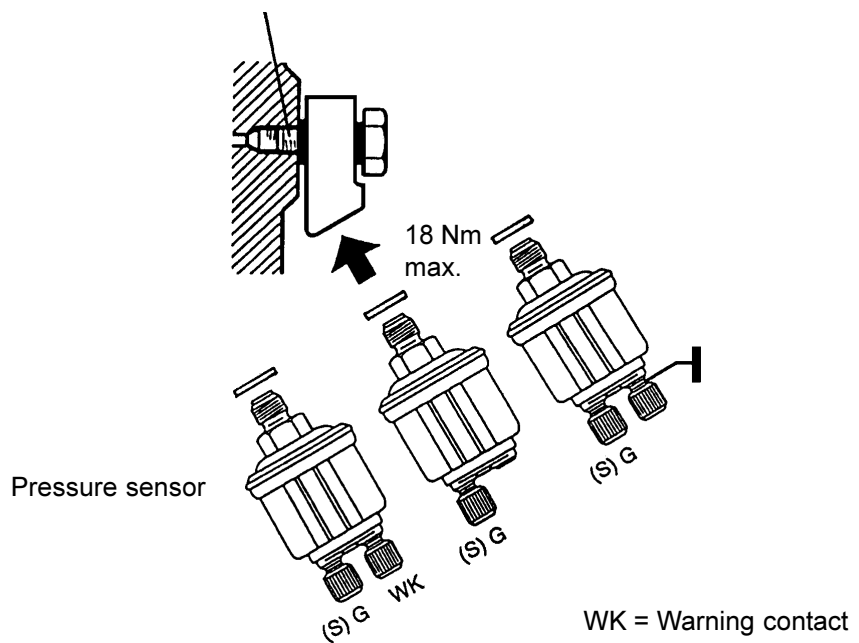

Technical Product Manual

VDO cockpit vision VDO cockpit international

6. Electric Pressure Gauge (dia. 52 mm)

6.3 Pressure Sensors

Adaptor kits for oil pressure sensors

Coupling

Part No. X11-360-004-011

M10 x 1



M16 x 1.5

Part No. X11-360-004-029

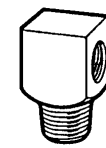

M12 x 1.5

M14 x 1.5 con.

Part No. X11-702-002-044

M10 x 1

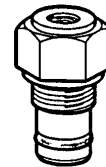

M18 x 1.5

Ask for the maximum torque (? Nm max.) from the engine manufacturer, equipment manufacturer or car manufacturer.

 ? Nm max.

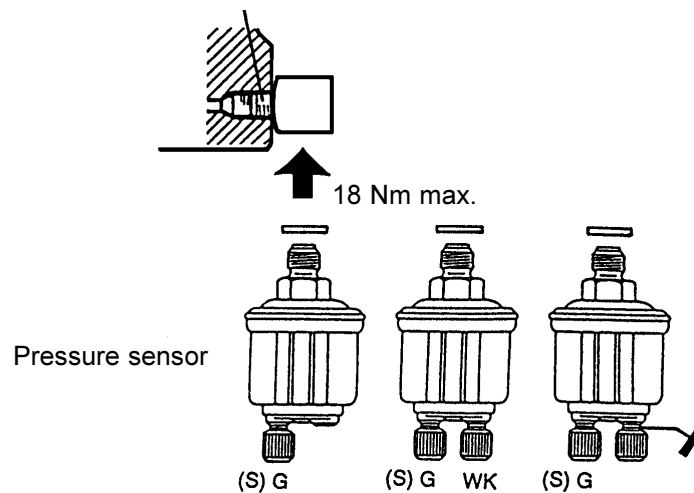

WK = Warning contact

Technical Product Manual

VDO cockpit vision VDO cockpit international

6. Electric Pressure Gauge (dia. 52 mm)

6.3 Pressure Sensors

Adaptor kits for oil pressure sensors

Coupling (hollow screw)

Part No. X11-360-004-016

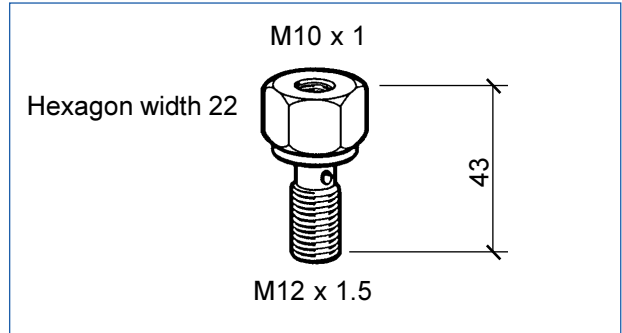

Part No. X11-360-004-019

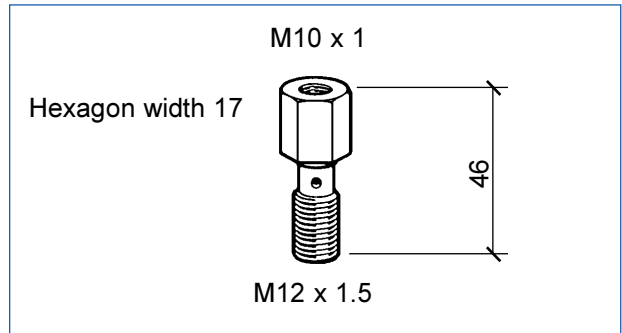

Coupling (hollow screw)

Pressure hose

Pressure hose

Pressure sensor

18 Nm max.

(S)G

(S)G

(S)G WK

WK = Warning contact

Ask for the maximum torque (? Nm max.) from the engine manufacturer, equipment manufacturer or car manufacturer.

Technical Product Manual

VDO cockpit vision VDO cockpit international

6. Electric Pressure Gauge (dia. 52 mm)

6.4 Wiring Diagrams

Pressure sensor:

negative earth
or
insulated earth

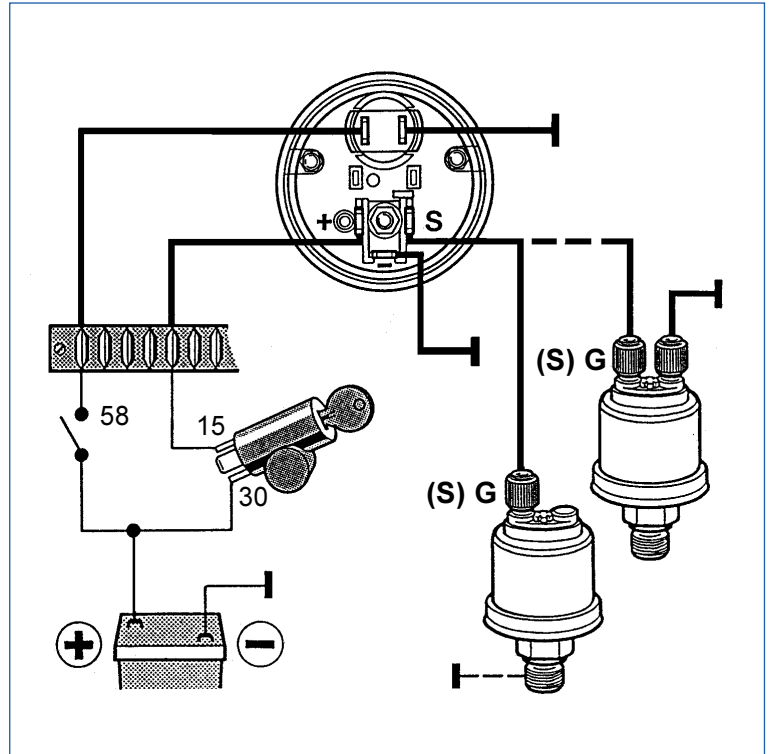

Pressure sensor with warning contact:

negative earth

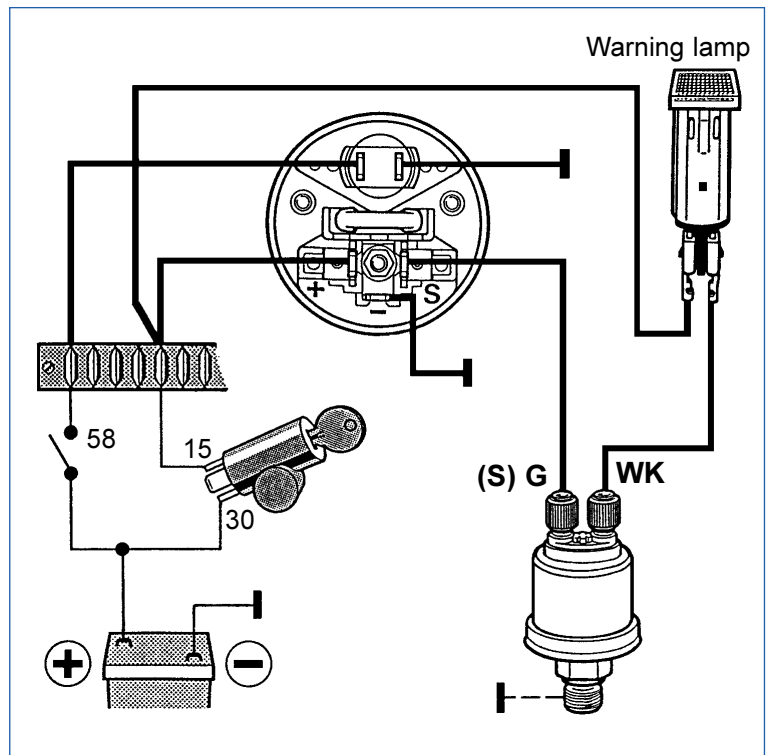

WK = Warning contact

Technical Product Manual

VDO cockpit vision VDO cockpit international

6. Electric Pressure Gauge (dia. 52 mm)

6.5 Testing Instructions

Test accessories

1x Power supply	} contained in test cables kit X12-019-101-001
1x Test cable No. 3	
1x Measuring cable	
1x Resistor decade	

Pin allocation

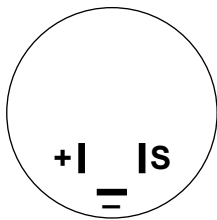

Pin + + 12V or + 24V
Pin - Ground
Pin S Sensor signal input

Test circuit diagram

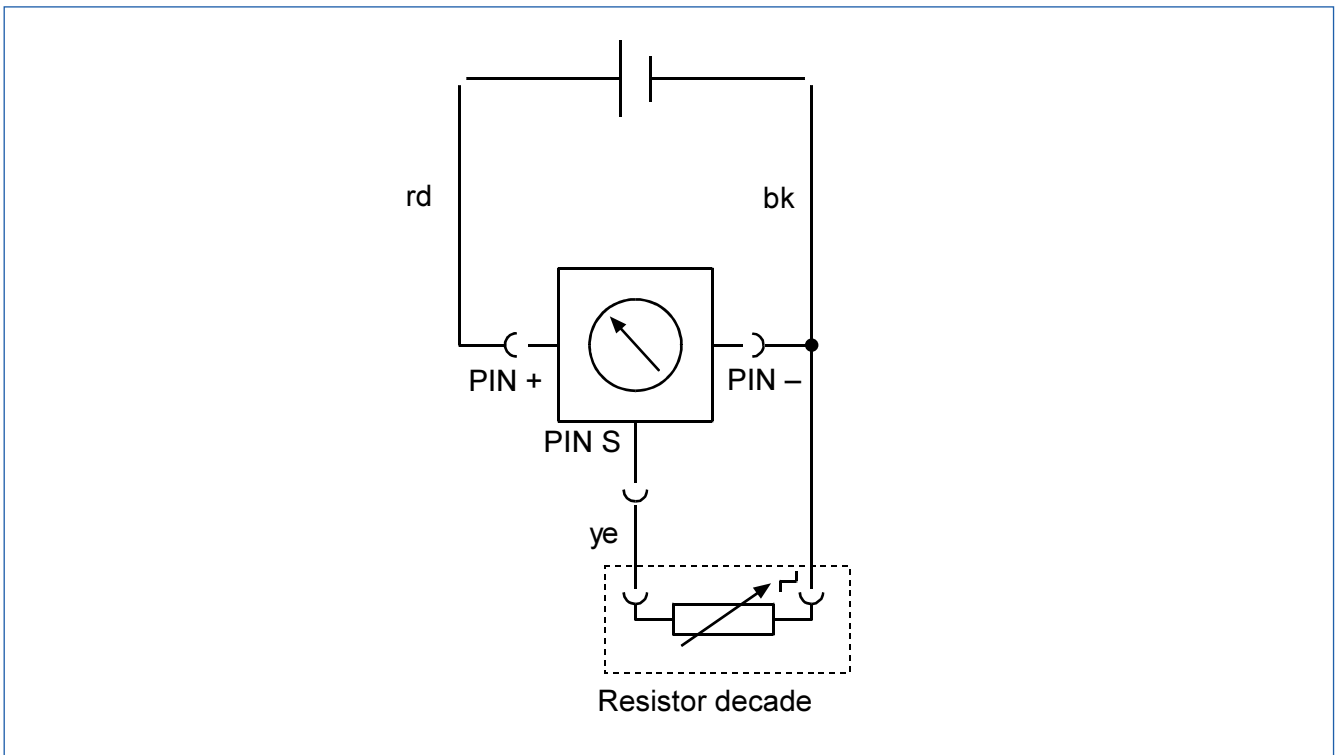

Test method description

Basic settings:	12 V instruments	»»»»»	14 V
	24 V instruments	»»»»»	28 V

Start the pointer position test with the highest resistance value!

Technical Product Manual

VDO cockpit vision VDO cockpit international

6. Electric Pressure Gauge (dia. 52 mm)

6.5 Testing Instructions

Test of the movement

Connect the instrument as shown in the test circuit diagram, using test cable 3.

The indication can be tested with the resistor decade 'sensor simulator'.

The pointer moves to full scale deflection if the resistor decade is not connected.

The following tables shows the resistance values and the indication in angular degrees.

0 to 2 bar

Indication (bar)	0	1	2
Resistance (Ω)	10	99	184
Deflection ($^\circ\angle$)	0	41.4	87.4

0 to 5 bar

Indication (bar)	0	0.5	1	1.5	2	2.5	3	3.5	4	4.5	5
Resistance (Ω)	10	30	48	65	82	99	116	134	151	168	184
Deflection ($^\circ\angle$)	0	6.4	13.4	21.3	30.6	41.4	53	64.6	74.2	81.6	87.4

0 to 10 bar

Indication (bar)	0	1	2	3	4	5	6	7	8	9	10
Resistance (Ω)	10	31	52	71	88	106	124	140	155	170	184
Deflection ($^\circ\angle$)	0	6.8	15.2	24.4	34.3	46.2	58.3	68.2	76.1	82.4	87.4

0 to 25 bar

Indication (bar)	0	2.5	5	7.5	10	12.5	15	17.5	20	22.5	25
Resistance (Ω)	10	32	53	73	92	109.1	125	143	155	169	184
Deflection ($^\circ\angle$)	0	7.1	15.6	25.5	36.8	42.7	58.9	69.9	76.1	82	87.4

Technical Product Manual





VDO cockpit vision VDO cockpit international

6. Electric Pressure Gauge (dia. 52 mm)

6.6 Instruments Survey

VDO cockpit vision (Backlight) dia. 52 mm

Part No. 350-010-...

Dial		Special feature	Part No.
Range	Imprint		
0 ... 5 bar	bar 	Clamp ring 12 V	008K
0 ... 5 bar	bar 	Stud bolts 12 V	014K
0 ... 10 bar	bar 	Clamp ring 12 V	007K
0 ... 10 bar	bar 	Stud bolts 12 V	015K
0 ... 150 PSI 0 ... 10 bar	PSI, bar 	Dual scale, clamp ring 12V without colour caps	019C

VDO cockpit vision (Backlight) dia. 52 mm

Part No. 350-020-...

Dial		Special feature	Part No.
Range	Imprint		
0 ... 10 bar	bar 	Clamp ring 24 V without colour caps	001C

Technical Product Manual







VDO cockpit vision VDO cockpit international

6. Electric Pressure Gauge (dia. 52 mm)

6.6 Instruments Survey











VDO cockpit international (Floodlight) dia. 52 mm

Part No. 350-030-...

Dial		Special feature	Part No.
Range	Imprint		
0 ... 5 bar	bar 	12 V	003C 003G
0 ... 10 bar	bar 	12 V	004C 004G
0 ... 25 bar	bar 	12 V	005C 005G
0 ... 10 bar	bar 	12 V	011C 011G
0 ... 5 x 100 kPa	kPa x 100 	12 V	016C
0 ... 10 x 100 kPa	kPa x 100 	12 V	017C
0 ... 80 psi 0 ... 5 bar	psi, bar 	12 V Dual scale	020C

VDO cockpit international (Floodlight) dia. 52 mm

Part No. 350-040-...

Dial		Special feature	Part No.
Range	Imprint		
0 ... 2 bar	bar 	24 V	001C
0 ... 5 bar	bar 	24 V	003C 003G
0 ... 10 bar	bar 	24 V	004C 004G
0 ... 25 bar	bar 	24 V	005C 005G
0 ... 10 bar	bar 	24 V	011C 011G
0 ... 5 x 100 kPa	kPa x 100 	24 V	016C
0 ... 10 x 100 kPa	kPa x 100 	24 V	017C
0 ... 80 psi 0 ... 5 bar	psi, bar 	24 V Dual scale	020C
0 ... 10 bar 0 ... 150 psi	bar, psi 	24 V Dual scale	015C
0 ... 400 psi 0 ... 25 bar	psi, bar 	24 V Dual scale	029C 029G
0 ... 5 bar	bar 	24 V	023C

Technical Product Manual

VDO cockpit vision VDO cockpit international

7. Electric Temperature Gauge (dia. 52 mm)

Contents	Page
7.1 General informations	7 - 2
7.2 Technical data	7 - 4
7.3 Temperature sensors	7 - 6
7.4 Wiring diagrams	7 - 10
7.5 Testing instructions	7 - 11
7.6 Instruments survey	7 - 13

Installation instructions

999-161-010:	VDO cockpit vision	(for oil)
999-161-002:	VDO cockpit international	(for oil)
999-161-019:	VDO cockpit vision	(for engine coolant)
999-161-017:	VDO cockpit international	(for engine coolant)

See file 'Installation Instructions (MA)'.

Technical Product Manual

VDO cockpit vision VDO cockpit international

7. Electric Temperature Gauge (dia. 52 mm)

7.1 General Informations

The electrical oil temperature gauge has been designed for land-bound vehicles or stationary systems only (exception: motorcycles).

The instrument has an analog temperature display graduated in °C or °F.

Temperature sensors of the following types, adapted to the indicator temperature range, can be used:

negative earth,
insulated earth,
negative earth with warning contact.



The lamp socket is clipped in.
To replace the light bulb, carefully, with the thumb,
push the lamp holder out to the side.

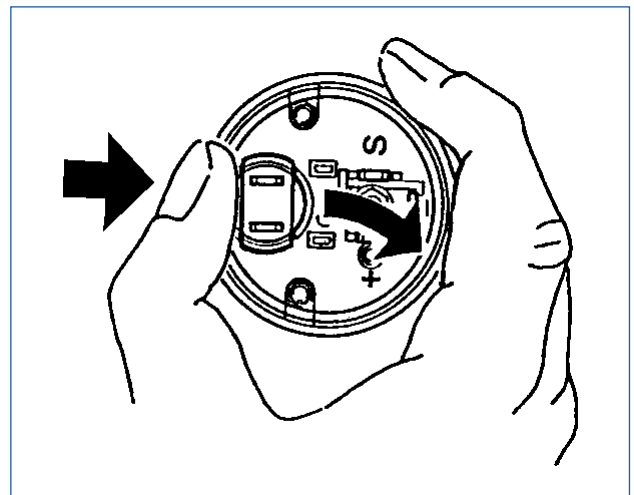

Technical Product Manual

VDO cockpit vision VDO cockpit international

7. Electric Temperature Gauge (dia. 52 mm)

Designation of function

Movement: System Ke (90°)

(Turning magnet movement for ratio indication, maximum pointer travel 90°)

The temperature indicator applies the resistance measurement principle. A sensor containing a resistor with strong temperature dependence (PTC) converts the temperature of the fluid to a corresponding resistance value.

A turning magnet ratio measuring movement measures this resistance value. This value is displayed by a pointer moving over a dial graduated in temperature units. The turning magnet movement for ratio indication comprises three stationary coils wound at 90° against each other, and a rotating permanent magnet disk in these coils. The coils are connected to determine a ratio, so that the instrument is insensitive to on-board voltage fluctuations.

This means that the pointer travel is only determined by the magnitude of the current flowing through the measuring system.

A magnetic shield prevents effects of external magnetic fields, indication errors due to temperature changes are corrected by a compensating resistor. A dropping resistor is used to adapt the measuring movement to higher operating voltages (e. g. 24V).

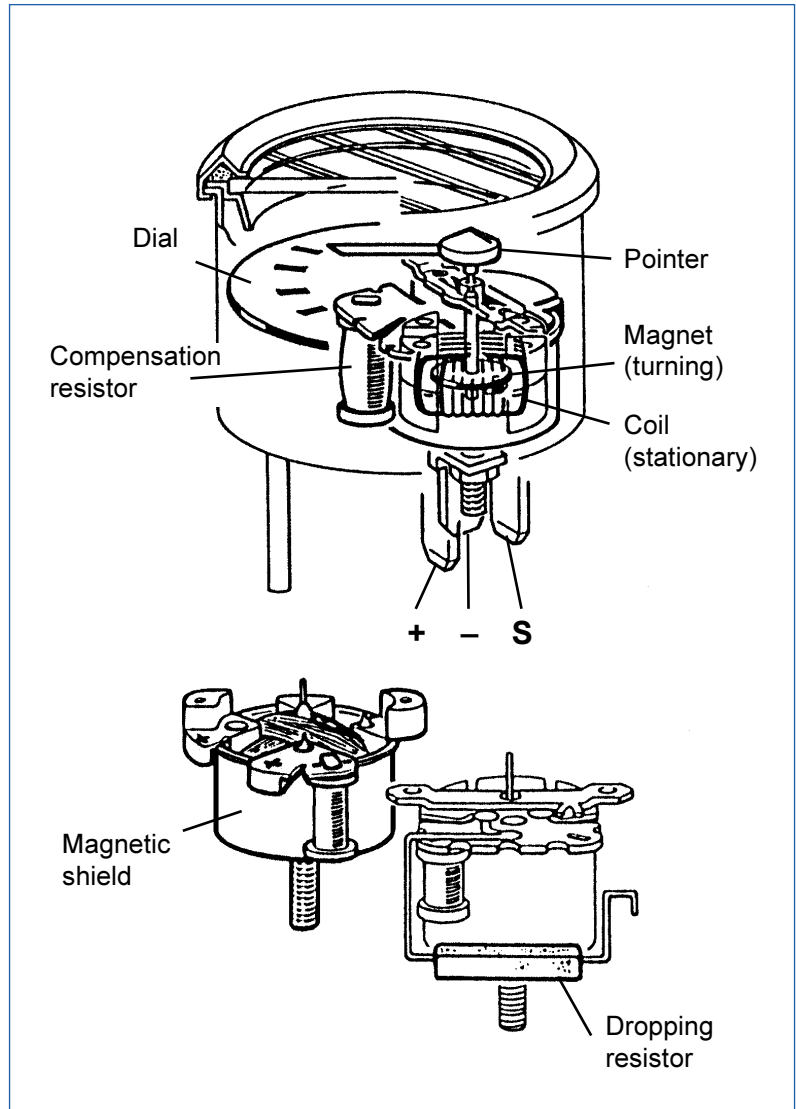

Technical Product Manual

VDO cockpit vision VDO cockpit international

7. Electric Temperature Gauge (dia. 52 mm)

7.2 Technical Data

Operating voltage:	11 ... 16 V or 21.5 ... 30 V
Movement:	System Ke (90°)
Current consumption:	131 mA (without illumination)
Operating temp.:	- 30°C ... + 85°C
Storage temperature:	- 40°C ... + 90°C
Illumination:	1 light bulb 14 V, 3.4 W or 24 V, 3 W 2 colour caps, green and red (only at 12 V)
Protection:	IP64 DIN 40050 from the front reverse-polarity protection
Vibration resistance:	max. 1g eff., 25 ... 2000 Hz, duration 8h, f. 1 octave/min.
Nominal position:	NL 0 to NL 90, DIN 16257

VDO cockpit vision
dia. 52 mm Backlight

Example: electric oil temperature gauge

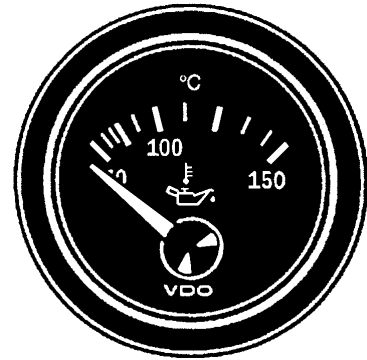

Sensor:
temperature sensor (thermistor),
not included.

Mounting hole: dia. 53mm

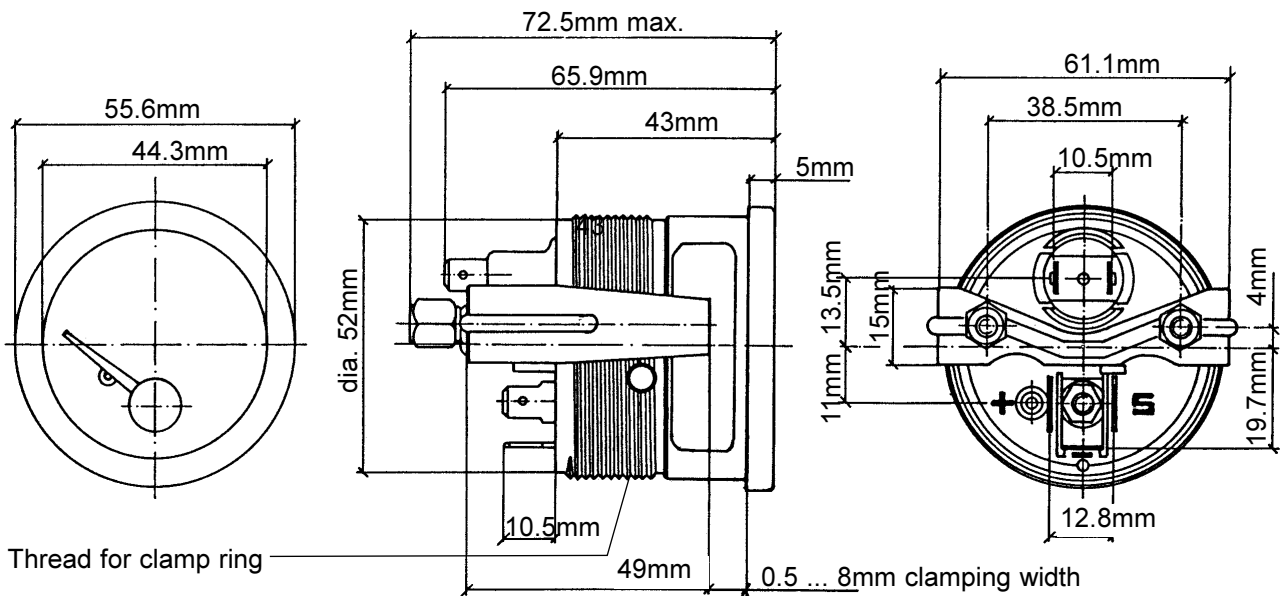

Thread for clamp ring

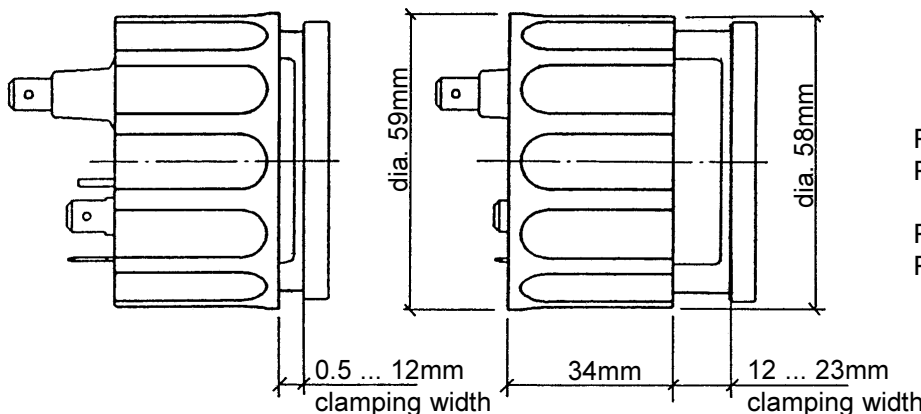

Pin assignment:

Pin +: + 12 V or + 24 V,
terminal 15

Pin -: Ground, terminal 31

Pin S: Sensor

Technical Product Manual

VDO cockpit vision VDO cockpit international

7. Electric Temperature Gauge (dia. 52 mm)

7.2 Technical Data

Operating voltage:	11 ... 16 V or 21.5 ... 30 V
Movement:	System Ke (90°)
Current consumption:	131mA (without illumination) 106mA = 60°C ... 200°C (without illumination)
Operating temp.:	- 30°C ... + 85°C
Storage temperature:	- 40°C ... + 90°C
Illumination:	1 light bulb 14 V, 3.4 W or 24 V, 3 W
Protection:	IP64 DIN 40050 from the front reverse-polarity protection
Vibration resistance:	max. 1g eff., 25 ... 2000 Hz, duration 8h, f. 1 octave/min.
Nominal position:	NL 0 to NL 90, DIN16 257

VDO cockpit international
dia. 52 mm Floodlight

Example:
electric oil temperature gauge

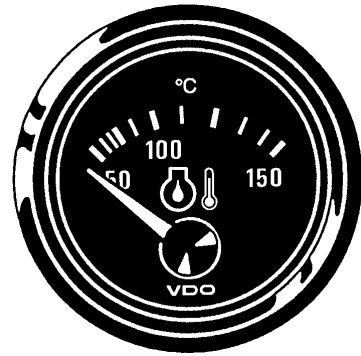

Sensor:
temperature sensor (thermistor),
not included.

Mounting hole: dia. 53mm

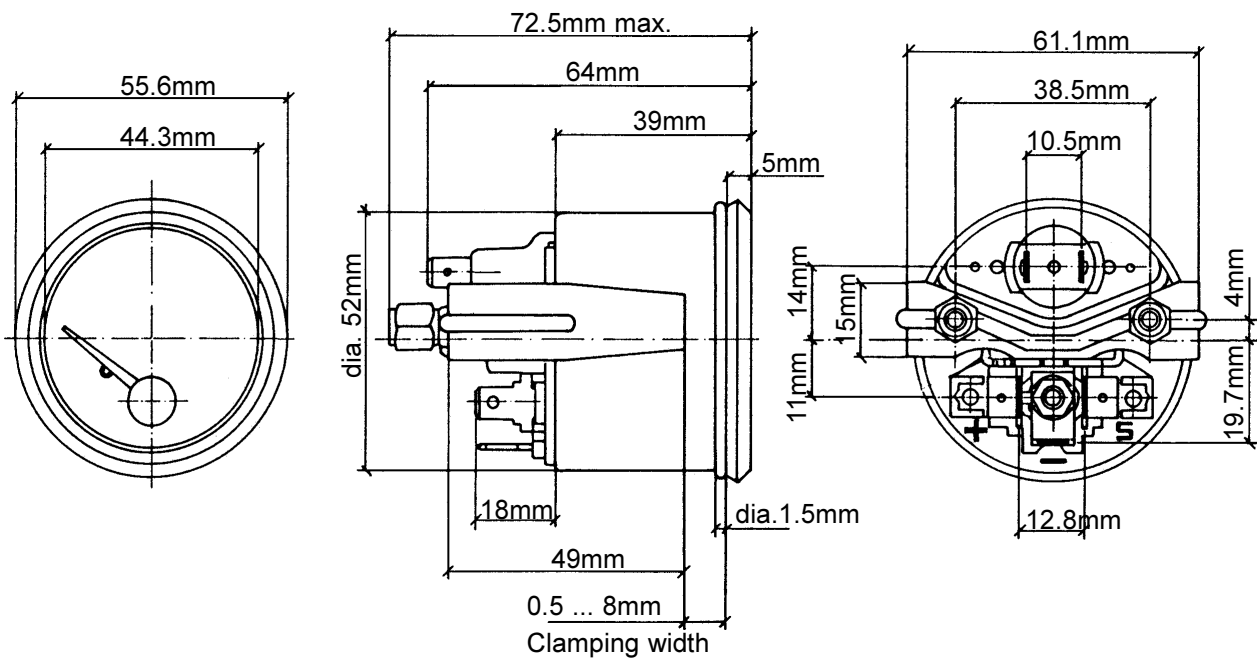

Pin assignment:
Pin +: + 12 V or + 24 V,
terminal 15
Pin -: ground, terminal 31
Pin S: Sensor

Technical Product Manual

VDO cockpit vision VDO cockpit international

7. Electric Temperature Gauge (dia. 52 mm)

7.3 Temperature Sensors

The temperature sensor needed to operate the instrument is not included with the instrument.

The following temperature sensors (see data sheets for sensors), adapted to the instrument indicating range, can be used:

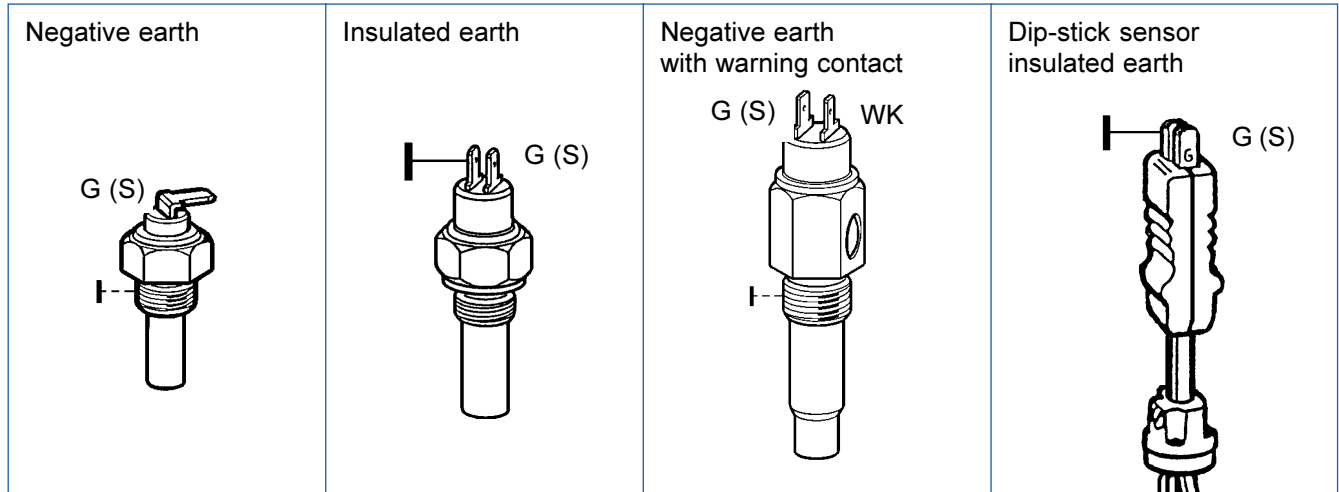

WK = Warning contact

Electric Oil Temperature Gauge

The sensor is installed in the oil circuit at a position specified by the vehicle manufacturer (e.g. oil drain plug).

A dip-stick sensor can be used instead of the standard dip-stick (original). The dip-stick sensor can be used for internal tube guide diameters from 6mm to 15mm.

Electric Engine Coolant Temperature Gauge

The sensor is installed in the engine coolant circuit at a position specified by the vehicle manufacturer (e.g. temperature warning switch) or in the coolant hose.

For installation in a coolant hose (28mm dia. to 35mm dia.) use installation kit, order No. X11-323-003-011.

Install in coolant hose just ahead of the radiator inlet opening.

Technical Product Manual

VDO cockpit vision VDO cockpit international

7. Electric Temperature Gauge (dia. 52 mm)

7.3 Temperature Sensors

To mount the temperature sensor it is absolutely only to use the hexagon nut.

If the connection thread is cylindrical, a sealing washer or a sealing ring made of copper must be fitted.

The values mentioned in the following table for the maximum tightening torque (Nm max.) refer exclusively to the load-bearing capacity of temperature sensors.



Prior to using the temperature sensor, it is important to ask the manufacturer of the vehicle, equipment system or engine in each instance for the maximum torque [? Nm max.] value for the threaded hole into which the temperature sensor is to be screwed. Non-observance of the maximum tightening torque specified for the threaded hole in each instance can result in damage to the vehicle, engine or equipment system.

Thread	max.
M 10 x 1	10 Nm
M 10 x 1	10 Nm
1/8 - 27 NPTF	10 Nm
M 12 x 1.5	15 Nm
1/2 - 20 Gang	15 Nm
M 14 x 1.25	20 Nm
M14 x 1.5	20 Nm
5/8 - 18 UNF - 3A	20 Nm
1/2 in. 20 Whit. S	20 Nm
1/4 - 18 NPTF	20 Nm
M 16 x 1.5	30 Nm
M 18 x 1.5	30 Nm
M 20 x 1.5	30 Nm
M 22 x 1.5	30 Nm
M 24 x 1.5	30 Nm
M 26 x 1.5	30 Nm
1/2 - 14 NPTF	30 Nm
3/8 - 18 NPTF	30 Nm
R 1/2	30 Nm
R 3/8	30 Nm
3/8 - 18 Dryseal NPTF	30 Nm
3/4-16 UNF-3A	30 Nm

Technical Product Manual

VDO cockpit vision VDO cockpit international

7. Electric Temperature Gauge (dia. 52 mm)

7.3 Temperature Sensors

Dip-stick sensor: installation information

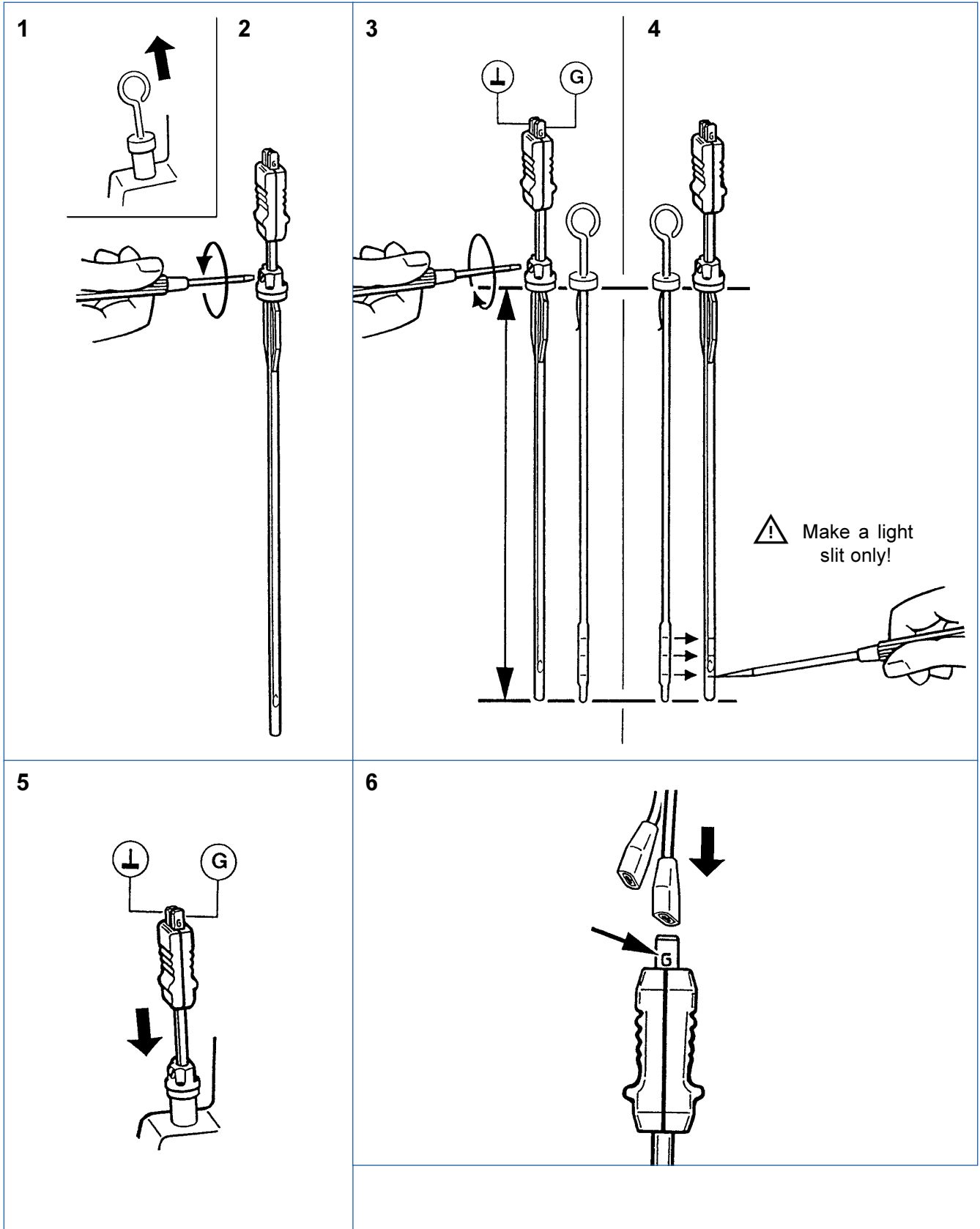

Technical Product Manual

VDO cockpit vision VDO cockpit international

7. Electric Temperature Gauge (dia. 52 mm)

7.3 Temperature Sensors

Installation kit for fitting into
28mm to 35mm diameter cooling water hoses

Part No. X11-323-003-011

Installation kit includes:

- 1 Temperature sensor (M14 x 1.5, 120°C max.)
- 2 Sealing washer
- 3 T-piece (inside dia. 32 mm, outside dia. 35 mm, 70 mm long, threaded connection M14 x 1.5, blade terminal 6.3 x 0.8 mm)
- 4 Hose clamp (2x)
- 5 Cable, brown (500 mm long)
- 6 Blade connector (6.3 x 0.8 mm)
- 7 Ring tongue

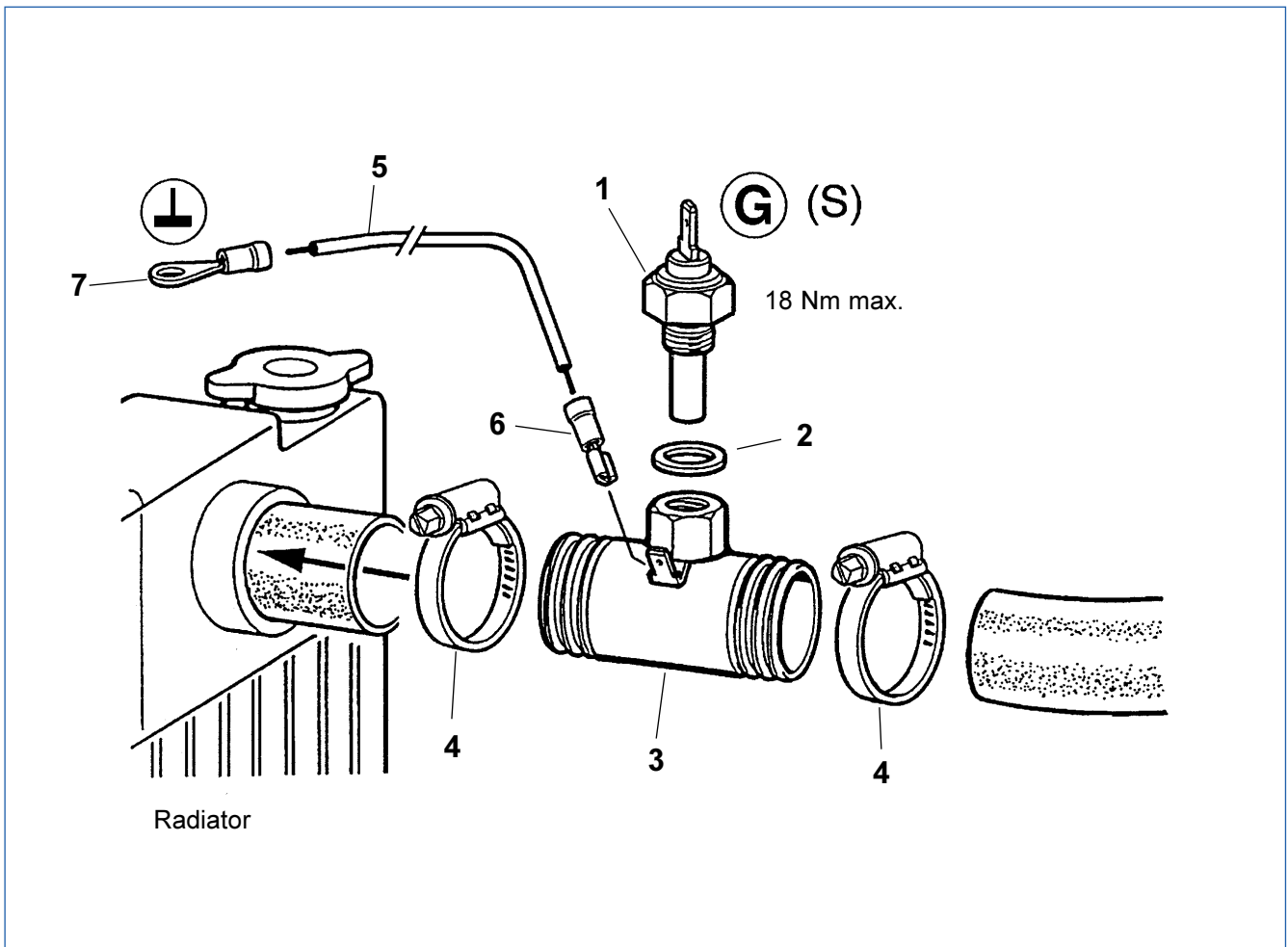

Technical Product Manual

VDO cockpit vision VDO cockpit international

7. Electric Temperature Gauge (dia. 52 mm)

7.4 Wiring Diagrams

Temperature sensor:

negative earth
or
insulated earth
or
dip-stick sensor insulated earth

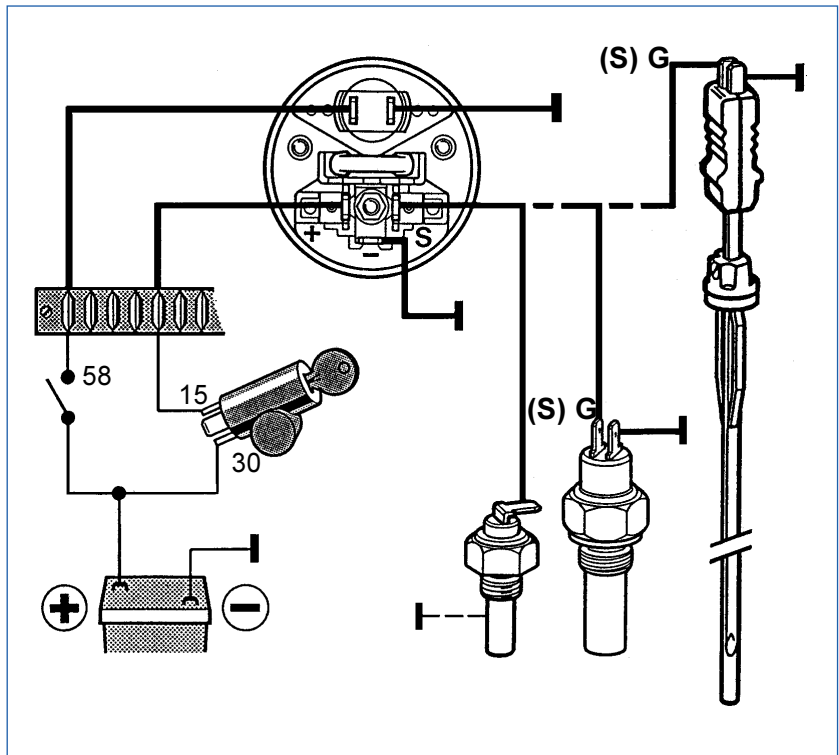

Temperature sensor:

negative earth with warning contact

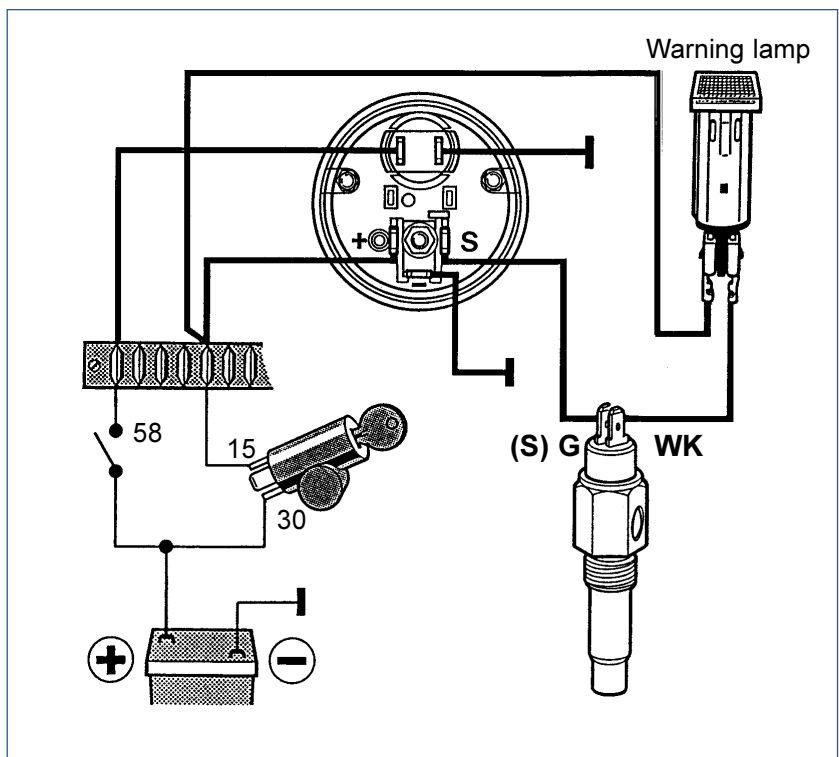

WK = Warning contact

Technical Product Manual

VDO cockpit vision VDO cockpit international

7. Electric Temperature Gauge (dia. 52 mm)

7.5 Testing Instructions

Test accessories

1x Power supply	} contained in test cables kit X12-019-101-001
1x Test cable No. 3	
1x Measuring cable	
1x Resistor decade	

Pin allocation

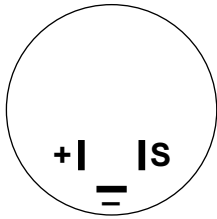

Pin + + 12V or + 24V
Pin - Ground
Pin S Sensor signal input

Test circuit diagram

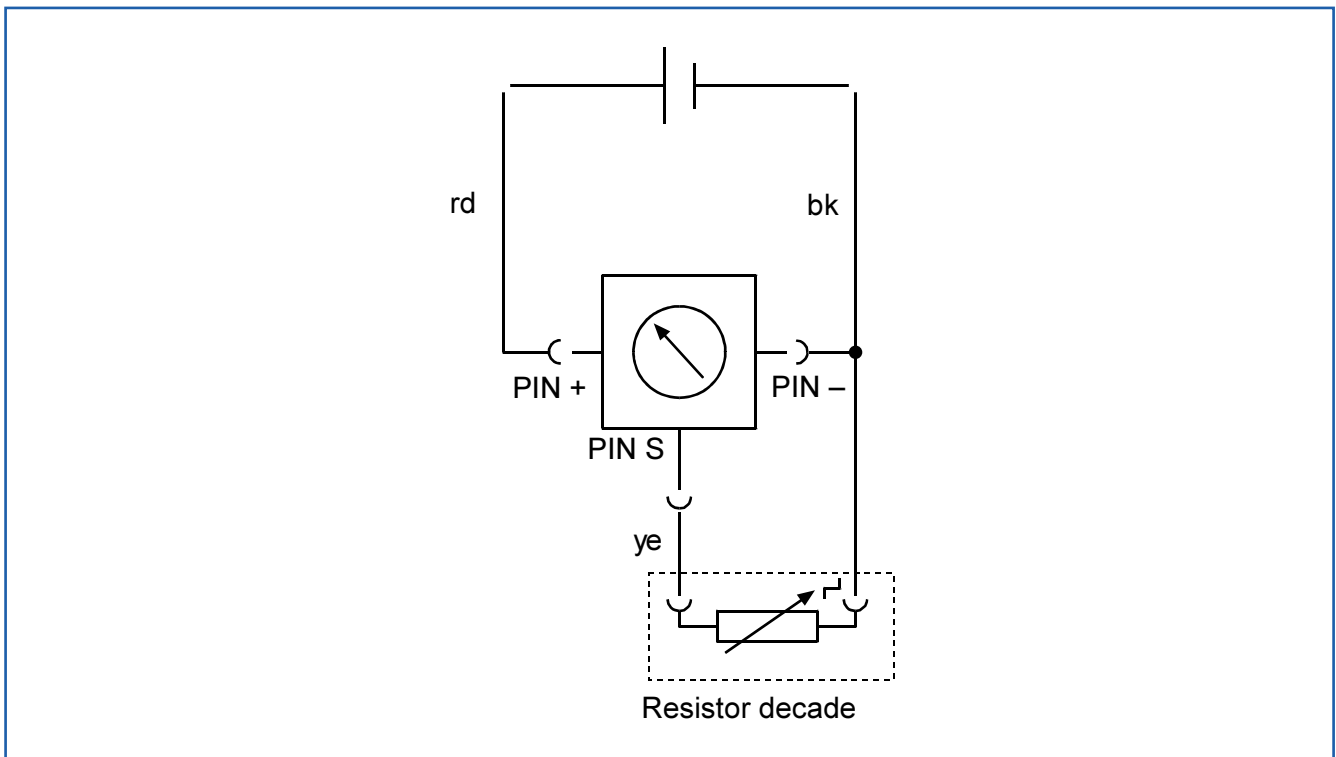

Test method description

Basic settings:	12 V instruments	»»»»	14 V
	24 V instruments	»»»»	28 V

Start the pointer position test with the highest resistance value!

Technical Product Manual

VDO cockpit vision VDO cockpit international

7. Electric Temperature Gauge (dia. 52 mm)

7.5 Testing Instructions

Test of the movement

Connect the instrument as shown in the test circuit diagram, using test cable 3.

The indication can be tested with the resistor decade 'sensor simulator'.

The following tables shows the resistance values and the permissible indication tolerances in angular degrees.

20 to 100 °C

Indication (°C)	20	40	60	80	100
Resistance (Ω)	700	287.4	134	69.1	38.5
Deflection (°∠)	0	27	60.5	80.5	90
Tolerance (°∠)	± 2.7	± 2.7	± 2.7	± 2.7	± 2.7

40 to 120 °C

Indication (°C)	40	50	60	70	80	90	100	110	120
Resistance (Ω)	287.4	193.3	134	95.2	69.1	51.3	38.6	29.4	22.7
Deflection (°∠)	0	3.3	8.3	15.5	25.8	40	58	75.2	88.2
Tolerance (°∠)	± 3.6	± 3.6	± 3.6	± 3.6	± 3.6	± 3.6	± 3.6	± 3.6	± 3.6

50 to 150 °C

Indication (°C)	50	80	90	100	110	120	130	140	150
Resistance (Ω)	322.8	112.5	83	62.2	47.5	36.5	28.9	23.1	18.6
Deflection (°∠)	0	12.4	19.8	29.6	42	56.8	69.7	80.2	88.1
Tolerance (°∠)	± 3.6	± 3.6	± 3.6	± 3.6	± 3.6	± 3.6	± 3.6	± 3.6	± 3.6

60 to 200 °C

Indication (°C)	60	100	140	180	200
Resistance (Ω)	482	165	50.8	25.7	14.3
Deflection (°∠)	0	11.9	43.9	78.9	88.9
Tolerance (°∠)	± 3.6	± 3.6	± 3.6	± 3.6	± 3.6

Technical Product Manual





VDO cockpit vision VDO cockpit international

7. Electric Temperature Gauge (dia. 52 mm)

7.6 Instruments Survey



VDO cockpit vision (Backlight) dia. 52 mm

Part No. 310-010-...

Dial		Special feature	Part No.
Range	Imprint		
50 ... 150 °C	°C 	Clamp ring 12 V	003K
50 ... 150 °C	°C 	Stud bolts 12 V	013K
40 ... 120 °C	°C 	Clamp ring 12 V	002K
40 ... 120 °C	°C 	Stud bolts 12 V	012K

VDO cockpit vision (Backlight) dia. 52 mm

Part No. 310-020-...

Dial		Special feature	Part No.
Range	Imprint		
50 ... 150 °C	°C 	Clamp ring 24 V without colour caps	002C
40 ... 120 °C	°C 	Clamp ring 24 V without colour caps	001C

Technical Product Manual







VDO cockpit vision VDO cockpit international

7. Electric Temperature Gauge (dia. 52 mm)

7.6 Instruments Survey









VDO cockpit international (Floodlight) dia. 52 mm

Part No. 310-030-...

Dial		Special feature	Part No.
Range	Imprint		
50 ... 150 °C	°C 	12 V	003C 003G
60 ... 200 °C	°C	12 V	004C 004G
40 ... 120 °C	°C 	12 V	013C 013G
50 ... 150 °C	°C 	12 V	015C 015G
20 ... 100 °C	°C 	12 V	022C
40 ... 120 °C	°C 	12 V	002C 002G
100 ... 250 °F 40 ... 120 °C	°F °C 	12 V Dual scale	020C

VDO cockpit international (Floodlight) dia. 52 mm

Part No. 310-040-...

Dial		Special feature	Part No.
Range	Imprint		
50 ... 150 °C	°C 	24 V	003C 003G
60 ... 200 °C	°C	24 V	004C 004G
40 ... 120 °C	°C 	24 V	013C 013G
50 ... 150 °C	°C 	24 V	015C 015G
120 ... 300 °F 50 ... 150 °C	°F °C 	24 V Dual scale	021C
20 ... 100 °C	°C 	24 V	022C
40 ... 120 °C	°C 	24 V	002C 002G
100 ... 250 °F 40 ... 120 °C	°F °C 	24 V Dual scale	020C
40 ... 120 °C	°C 	24 V	025C

Technical Product Manual

VDO cockpit vision VDO cockpit international

8. Electric Fuel Level Gauge (dia. 52mm) (Fuel Level Sensor, Lever-Type)

Contents	Page
8.1 General informations	8 - 2
8.2 Technical data	8 - 4
8.3 Lever-type fuel level sensors	8 - 6
8.4 Wiring diagram	8 - 13
8.5 Testing instructions	8 - 14
8.6 Instruments survey	8 - 16

Installation instructions

999-161-012: VDO cockpit vision
999-161-004: VDO cockpit international

See file 'Installation Instructions (MA)'.

Technical Product Manual

VDO cockpit vision VDO cockpit international

8. Electric Fuel Level Gauge (dia. 52mm) (Fuel Level Sensor, Lever-Type)

8.1 General Informations

The electric fuel level gauge has been designed for land-bound vehicles or stationary systems only (exception: motorcycles).

The instrument has an analog tank fuel level display graduated in fuel levels.



The lamp socket is clipped in.
To replace the light bulb, carefully, with the thumb,
push the lamp holder out to the side.

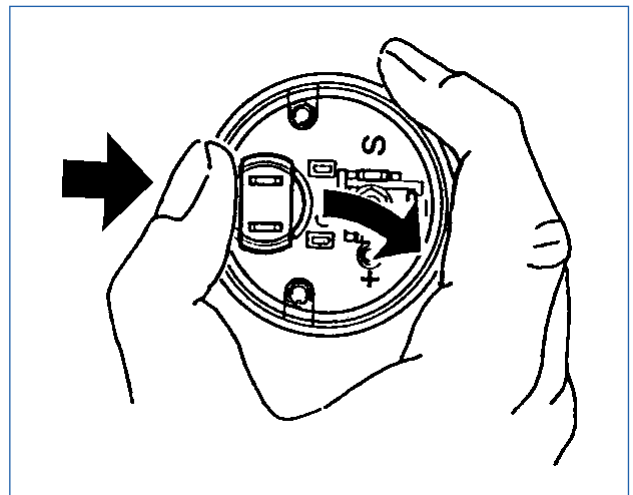

Technical Product Manual

VDO cockpit vision VDO cockpit international

8. Electric Fuel Level Gauge (dia. 52mm) (Fuel Level Sensor, Lever-Type)

8.1 General Informations

Designation of function

Movement: System Ke (90°)

(Turning magnet movement for ratio indication, maximum pointer travel 90°)

The fuel reserve indicator applies the resistance measurement principle. A sensor (lever-type) in the liquid reserve to a corresponding resistance value. A turning magnet ratio measuring movement measures this resistance value.

It comprises three stationary coils wound at 90° against each other, and a rotating permanent magnet disk in these coils. The coils are connected to determine a ratio, so that the instrument is intensive to on-board voltage fluctuations. This means that the pointer travel is only determined by the magnitude of the current flowing through the measuring system.

The pointer movement must be damped when the liquid level is measured by a lever-type sensor; in this case the coil body is filled with dampening oil, the rotating magnet moves in this oil to obtain dampened pointer movements.

A magnetic shield prevents effects of external magnetic fields, indication errors due to temperature changes are corrected by a compensating resistor.

A dropping resistor is used to adapt the measuring movement to higher operating voltage (e. g. 24V).

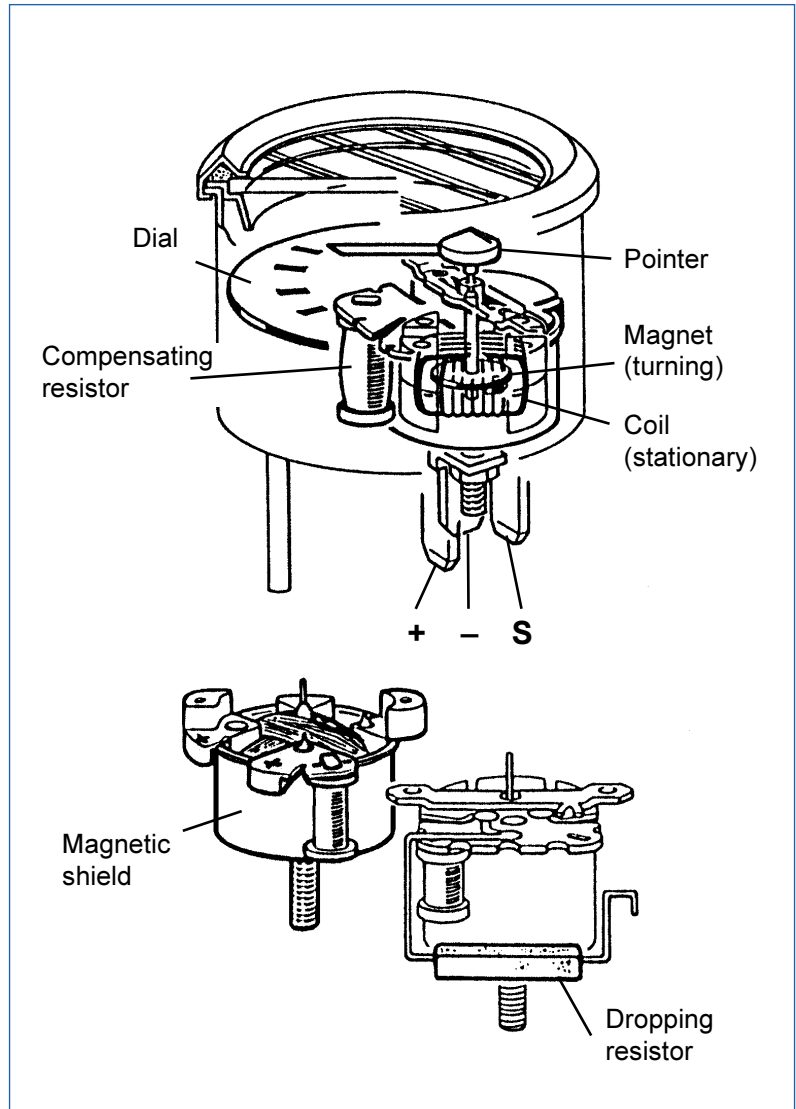

Technical Product Manual

VDO cockpit vision VDO cockpit international

8. Electric Fuel Level Gauge (dia. 52mm) (Fuel Level Sensor, Lever-Type)

8.2 Technical Data

Operating voltage:	11 ... 16 V or 21.5 ... 30 V
Movement:	System Ke (90°)
Current consumption:	86 mA (without illumination)
Operating temp.:	- 30°C ... + 85°C
Storage temperature:	- 40°C ... + 90°C
Illumination:	1 light bulb 14 V, 3.4 W or 24 V, 3 W, 2 colour caps, green and red (only at 12 V)
Protection:	IP64 DIN 40050 from the front reverse-polarity protection
Vibration resistance:	max. 1g eff., 25 ... 2000 Hz, duration 8 h, f: 1 octave/min.
Nominal position:	NL 0 to NL 90, DIN 16257

VDO cockpit vision
dia. 52 mm Backlight



Mounting hole: dia. 53mm

Sensor: lever-type sensor
(not included)

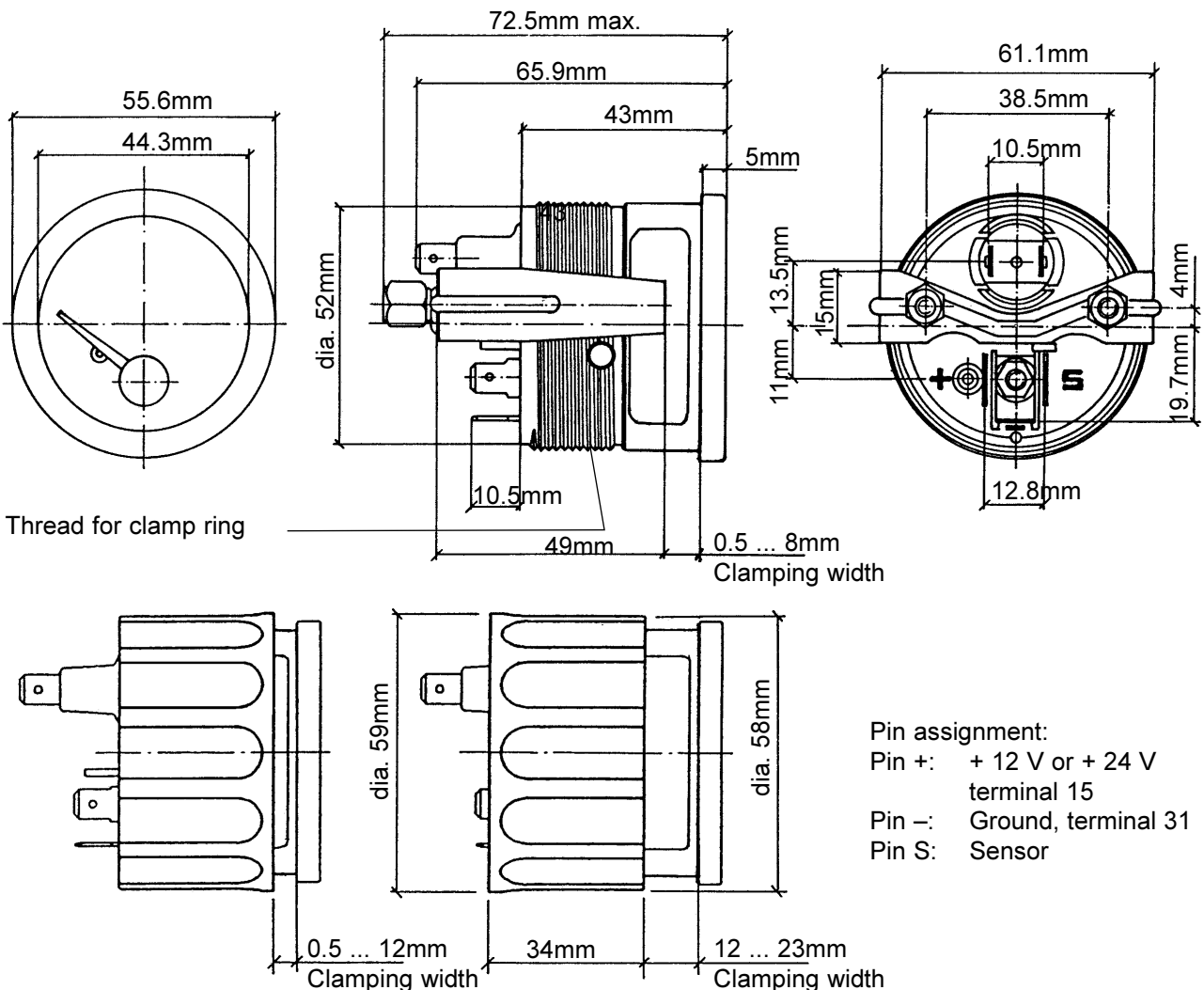

Pin assignment:
Pin +: + 12 V or + 24 V
terminal 15
Pin -: Ground, terminal 31
Pin S: Sensor

Technical Product Manual

VDO cockpit vision VDO cockpit international

8. Electric Fuel Level Gauge (dia. 52mm) (Fuel Level Sensor, Lever-Type)

8.2 Technical Data

Operating voltage:	11 ... 16 V or 21.5 ... 30 V
Movement:	System Ke (90°)
Current consumption:	86 mA (without illumination)
Operating temp.:	- 30°C ... + 85°C
Storage temperature:	- 40°C ... + 90°C
Illumination:	1 light bulb 14 V, 3.4 W or 24 V, 3 W
Protection:	IP64 DIN 40050 from the front reverse-polarity protection
Vibration resistance:	max. 1g eff., 25 ... 2000 Hz, duration 8 h, f: 1 octave/min.
Nominal position:	NL 0 to NL 90, DIN 16257

VDO cockpit international
dia. 52 mm Floodlight



Mounting hole: dia. 53mm

Sensor: lever-type sensor
(not included)

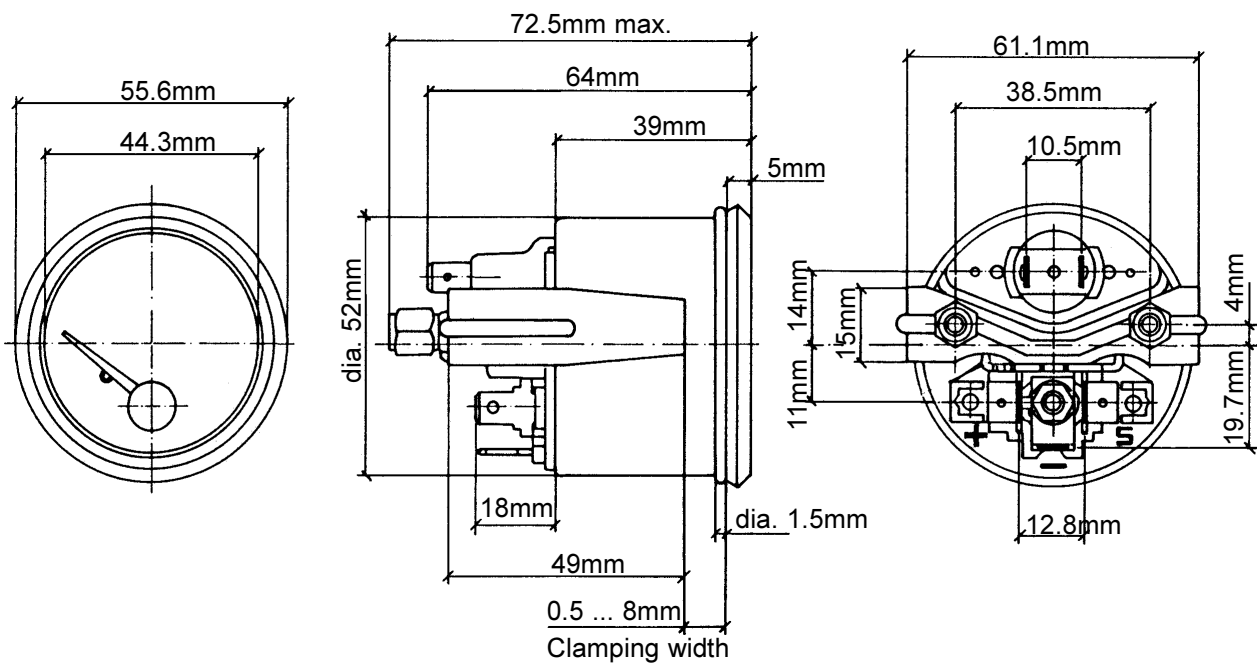

Pin assignment:

Pin +: + 12 V or + 24 V
terminal 15

Pin -: Ground, terminal 31

Pin S: Sensor

Technical Product Manual

VDO cockpit vision VDO cockpit international

8. Electric Fuel Level Gauge (dia. 52mm) (Fuel Level Sensor, Lever-Type)

8.3 Lever-Type Fuel Level Sensors

The lever-type sensor needed to operate the instrument is not included with the instrument.
The following lever-type sensors (see data sheets for sensors) can be used:

I) Standard lever-type sensor

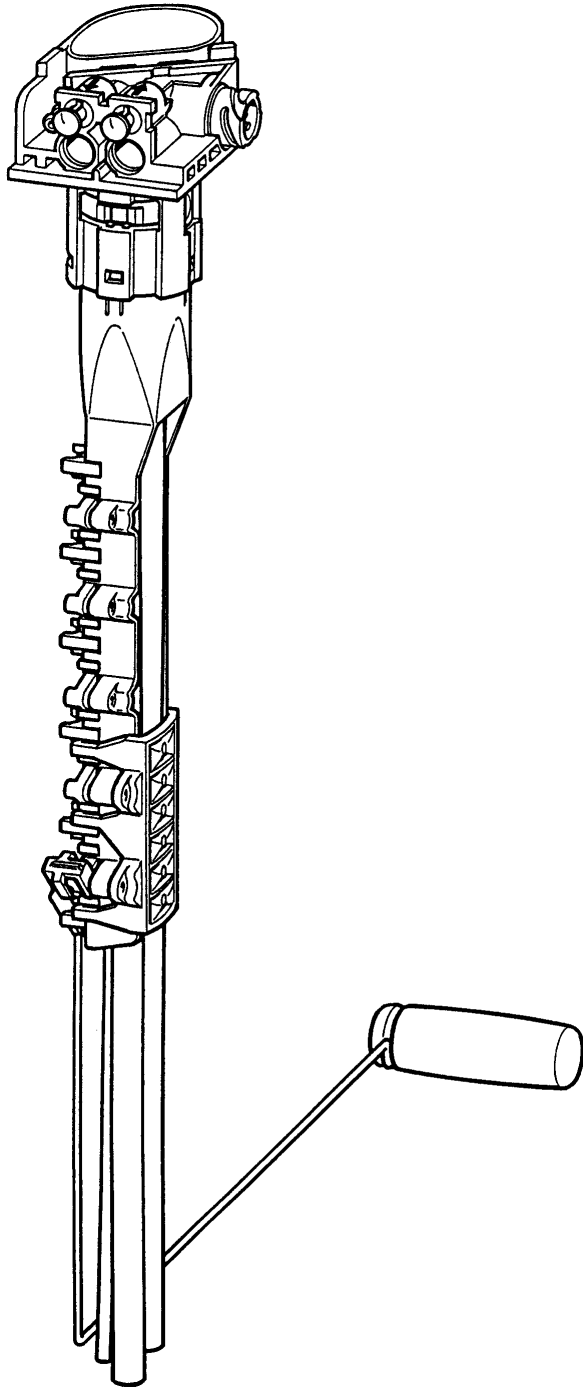

II) Lever-type sensor, adjustable

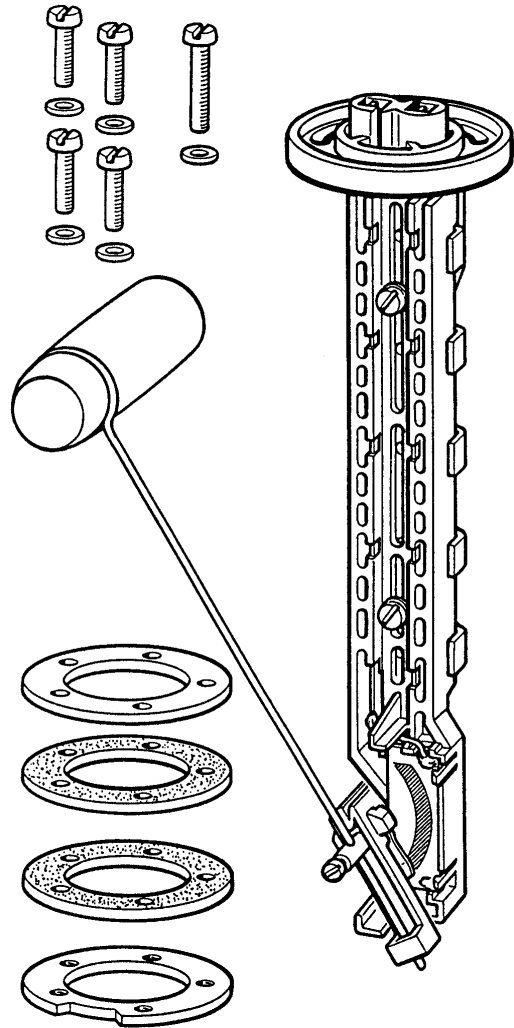

Technical Product Manual

VDO cockpit vision VDO cockpit international

8. Electric Fuel Level Gauge (dia. 52mm) (Fuel Level Sensor, Lever-Type)

8.3 Lever-Type Fuel Level Sensors

I) Standard lever-type sensor (6V to 24V, insulated earth), part No.: 221-824-054-...C

Version, variations:

- plastic lever-type sensor with bayonet flange for 1.5 mm or 2 mm tank sheet thickness
- is available in different lengths
- different lift of float arm
- different orientation of the lever arm to the connections on the flange
- integrated fuel feed and return
- DIN bayonet connector for electric supply
- easy connection of external heating
- integrated tank ventilation with suction and pressure relief valves
- potentiometer designed as thick-film resistor
- pressure compensation possible in case of several tanks (twin-tank equipment)

Accessories

- Sealing: the sensor is sealed to the tank by a rubber O-ring (part No. 89-356-017).



With this sealing, compensation of different sheet thicknesses is not intended.

- Bayonet connector for electric supply:
connector with 2 receptacles with sealings (DIN 72585), commercially available, e. g. AMP 964 613-1.

- Fuel supply fitting for connection of fuel feed and return
Use of the integrated feed and return requires two fittings (part No. X11-221-001-002 = inside diameter 8mm).

This fitting is replaceable, so you can adjust the diameter of the feed pipe to individual requirements. Both fittings and any additional connections are protected against working loose or slipping off by means of the locking (part No. X11-221-001-003).

- Fitting for external heating

A separate feed and return for operation of an additional heating is provided. The sensor will be delivered with both openings sealed with plastic plug. The return connection of the heating can also be used for pressure compensation with another tank. The fittings for the external heating are the part No. X11-221-001-004.

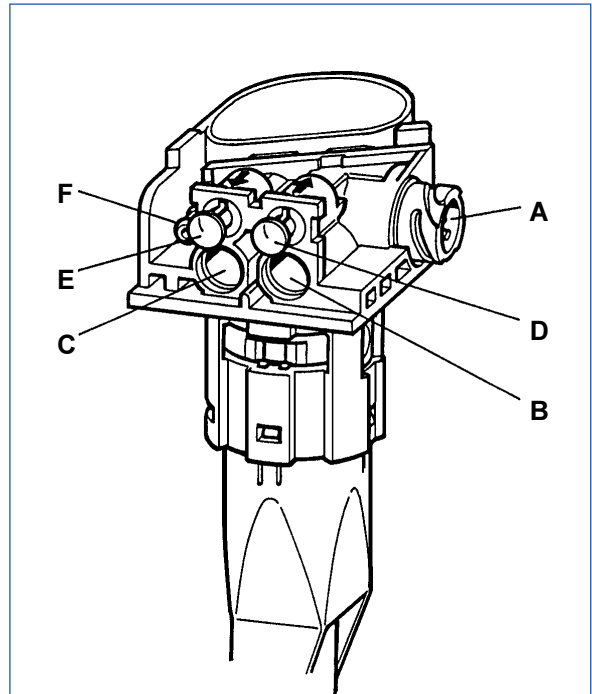

- A Bayonet connector
DIN 72585 (A1-2.1 SN/K1)
- B Fuel return
- C Fuel feed
- D Return for external heating or pressure compensation with other tanks
- E Feed for external heating
- F Ventilation by means of valves

Tank mounting hole:
(burr outside of the tank)

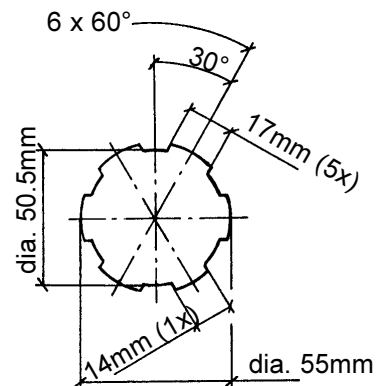

Sheet thickness 1.5mm or 2mm

Technical Product Manual

VDO cockpit vision VDO cockpit international

8. Electric Fuel Level Gauge (dia. 52mm) (Fuel Level Sensor, Lever-Type)

8.3 Lever-Type Fuel Level Sensors

I) Standard lever-type sensor (6V to 24V, insulated earth), part No.: 221.824/054/. . .C

Installation instructions

- The individual sensors are designed for tank bayonet sheet thickness of 1.5mm or 2mm.
Tolerances: 1.5mm (1.25 ... 1.55mm), for part No. 221-824-054-049C, -050C, -051C, -054C, -056C, -056C
2.0mm (1.85 ... 2.15mm), for part No. 221-824-054-052C, -053C
- With the sealings, compensation of different sheet thicknesses is not intended.
- To determine the required minimum tank-wall clearance, add 1/2 of the float diameter to the lever radius.
The float diameter of all variants is 31mm.
- The customer may procure the fittings for fuel feed and return himself, so other fuel feed pipe diameters can be implemented.
- The bayonet connection principally allows mounting in just one defined direction.
The mounting position has to be strictly observed.
- The lever-type sensor is equipped with several link points for the lever arm. These link points serve to adjust the lever-type sensor length in production. Later shortening of the sensor length may destroy the sensor. Therefore, it is not possible to adjust the length individually by the customer or the sales organisation.
- When fitting the lever-type sensor into the tank, it must not be overtightened in order to not to be stripped. The maximum torque of 18 Nm to 20 Nm has to be strictly observed.

Technical Product Manual

VDO cockpit vision VDO cockpit international

8. Electric Fuel Level Gauge (dia. 52mm) (Fuel Level Sensor, Lever-Type)

8.3 Lever-Type Fuel Level Sensors

II) Lever-type sensor, adjustable (6V to 24V, insulated earth), part No.: 226-801-015-001G

Version:

- adjustable lever-type sensor (plastic casing) with flange hole circle dia. 54 mm
- flanges, gaskets and small parts are included
- for fuel tanks having a height from 150mm to 605mm
- 2 blade terminals 6.3 x 0.8 mm

Sensor installation position

The sensor is installed in a mounting hole (dia. 60mm) made in the tank at a good position for fuel measurement, or on a mounting flange provided by the tank manufacturer, or in an existing mounting hole.

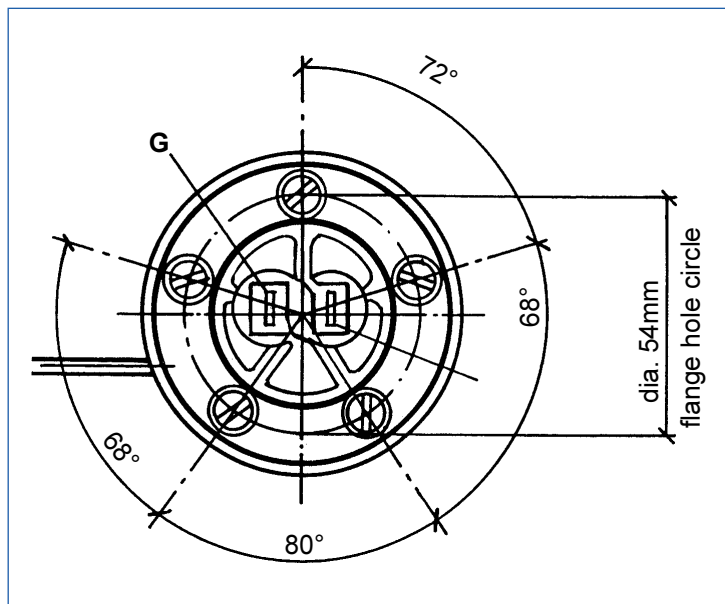
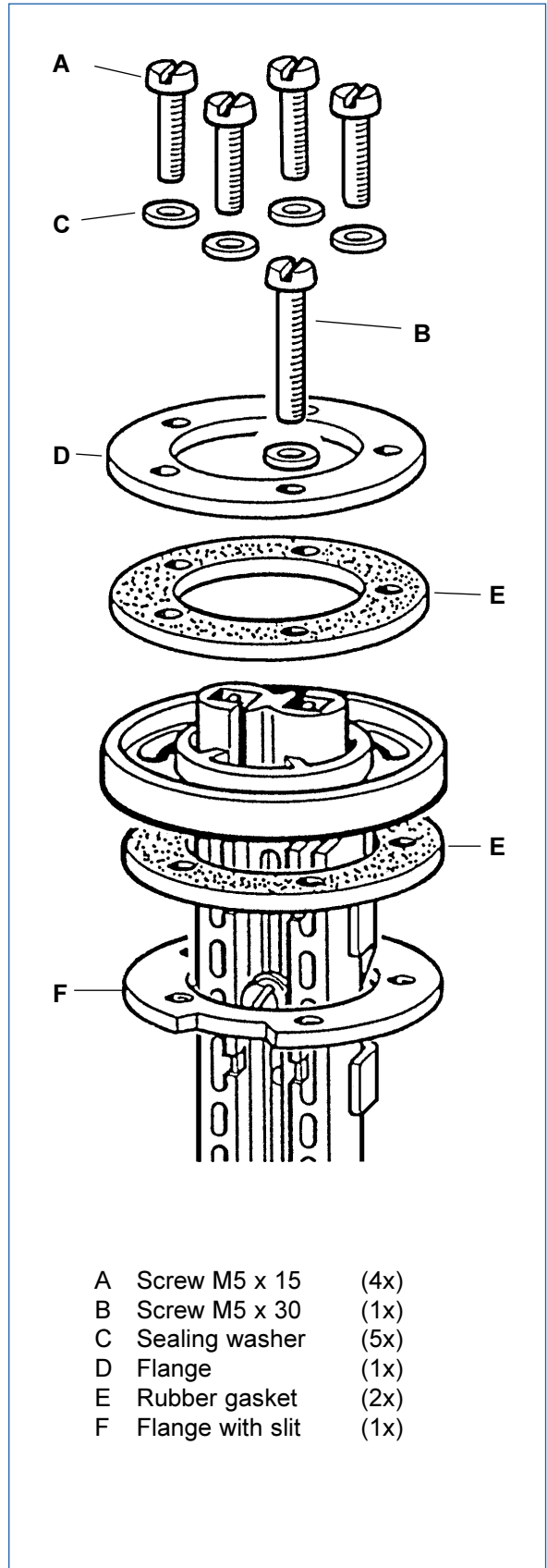

- | | | |
|---|------------------|------|
| A | Screw M5 x 15 | (4x) |
| B | Screw M5 x 30 | (1x) |
| C | Sealing washer | (5x) |
| D | Flange | (1x) |
| E | Rubber gasket | (2x) |
| F | Flange with slit | (1x) |

Technical Product Manual

VDO cockpit vision VDO cockpit international

8. Electric Fuel Level Gauge (dia. 52mm) (Fuel Level Sensor, Lever-Type)

8.3 Lever-Type Fuel Level Sensors

II) Lever-type sensor, adjustable (6V to 24V, insulated earth)

Adjustment

Adjust the length (L) of the sensor body and the radius (R) of the float lever according to the height (H) of the fuel tank.

Float lever install only so!

H	L	R
360	180	225
365	182,5	228
370	185	231
375	187,5	234
380	190	238
385	192,5	241
390	195	244
395	197,5	247
150	075	094
155	077,5	097
160	080	100
165	082,5	103
170	085	106
175	087,5	109
180	090	112
185	092,5	115
190	095	119
195	097,5	122
200	100	125
205	102,5	128
210	105	131
215	107,5	134
220	110	137
225	112,5	140
230	115	144
235	117,5	147
240	120	150
245	122,5	153
250	125	157
255	127,5	160
260	130	163
265	132,5	166
270	135	169
275	137,5	172
280	140	175
285	142,5	178
290	145	181
295	147,5	184
300	150	187
305	152,5	191
310	155	194
315	157,5	197
320	160	200
325	162,5	203
330	165	206
335	167,5	209
340	170	212
345	172,5	216
350	175	219
355	177,5	222

Technical Product Manual

VDO cockpit vision VDO cockpit international

8. Electric Fuel Level Gauge (dia. 52mm) (Fuel Level Sensor, Lever-Type)

8.3 Lever-Type Fuel Level Sensors

II) Lever-type sensor, adjustable (6V to 24V, insulated earth)

Installation informations

If an installation opening must be made, the tank must be completely drained first. Fill the fuel into an approved container. Remove the tank whenever possible. Comply with the safety instructions of the automobile manufacturer for any work performed under the automobile.

 Risk of explosion exists due to presence of residual gases in the tank!
Make sure that the tank is aired sufficiently (approx. 10 minutes).

Make a preliminary hole in the installation opening using a drill and then finish the hole using a compass saw or piercing saw. Comply with the safety instructions of the tool manufacturer. Clean the tank of residue from the drilling or sawing work.

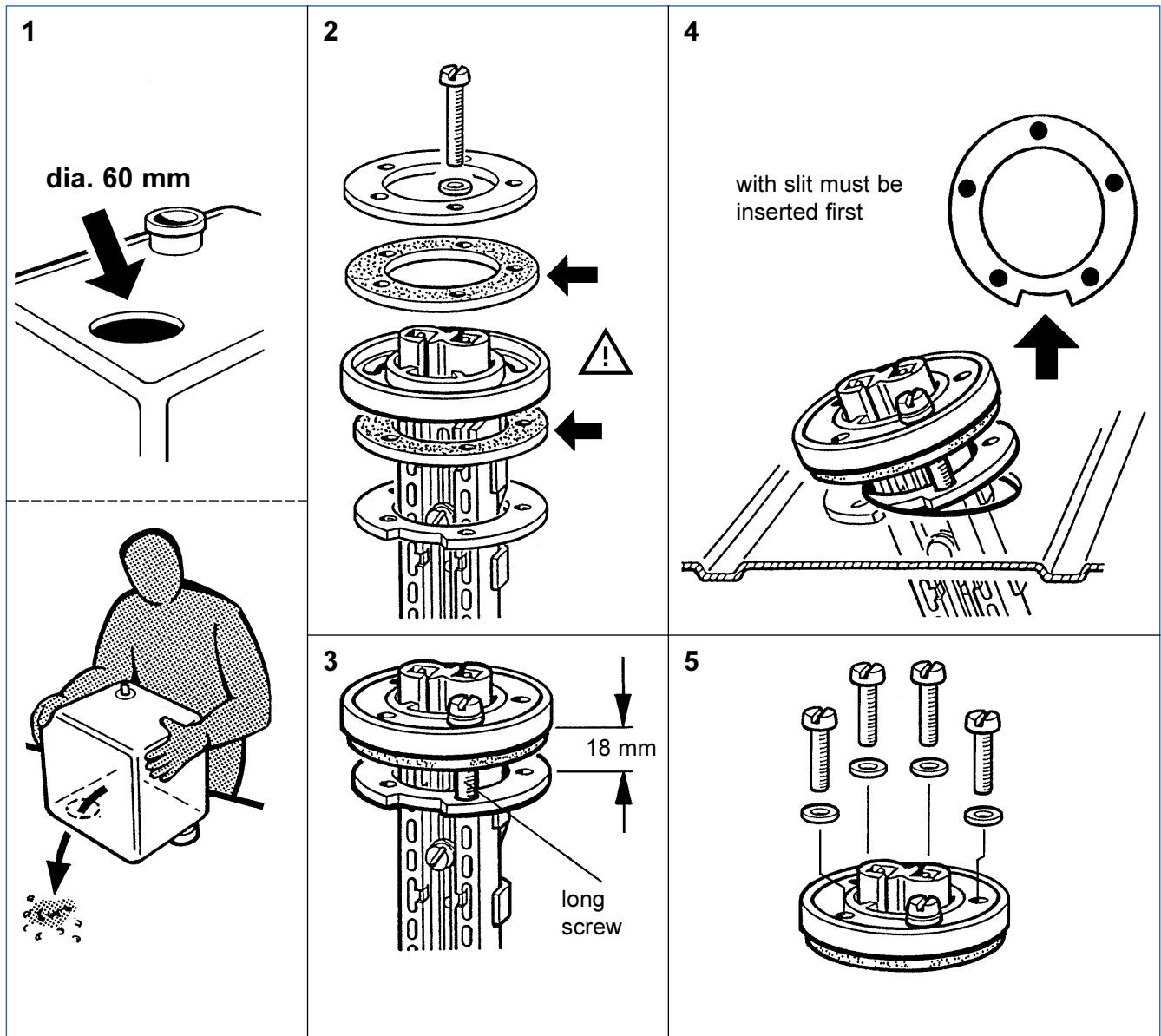

Technical Product Manual

VDO cockpit vision VDO cockpit international

8. Electric Fuel Level Gauge (dia. 52mm) (Fuel Level Sensor, Lever-Type)

8.3 Lever-Type Fuel Level Sensors

II) Lever-type sensor, adjustable (6V to 24V, insulated earth)

Installation informations for a tank mounting hole with threaded bolts:

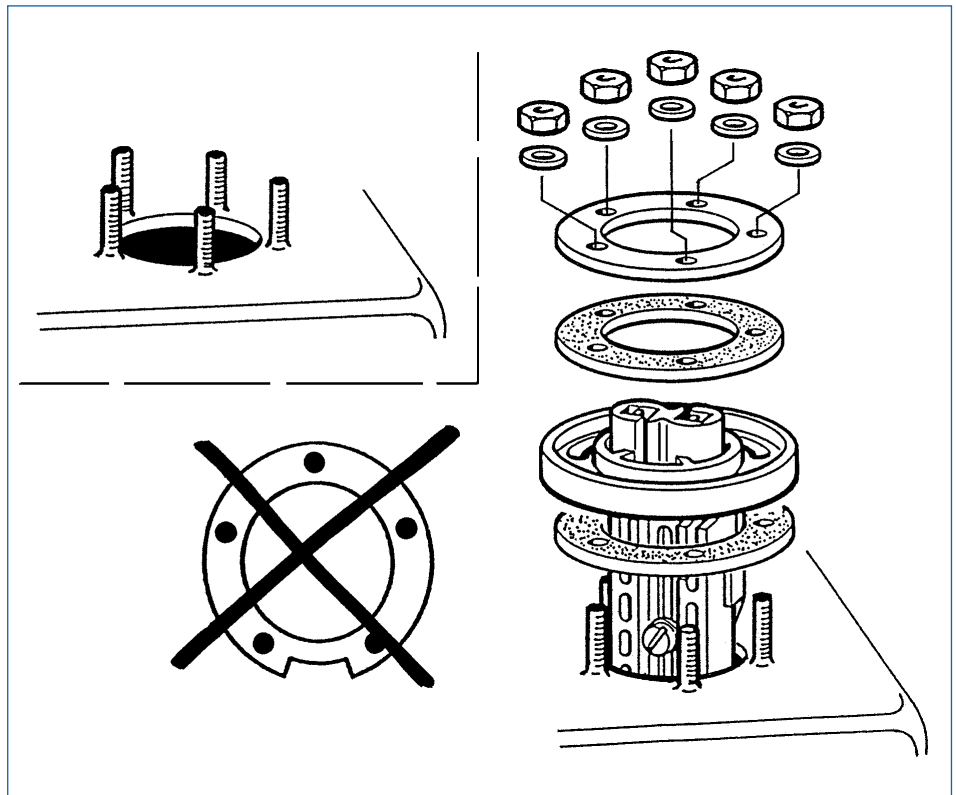

III) Lever-type sensor, special versions

See data sheets for sensors.

Technical Product Manual

VDO cockpit vision VDO cockpit international

8. Electric Fuel Level Gauge (dia. 52mm) (Fuel Level Sensor, Lever-Type)

8.4 Wiring Diagram

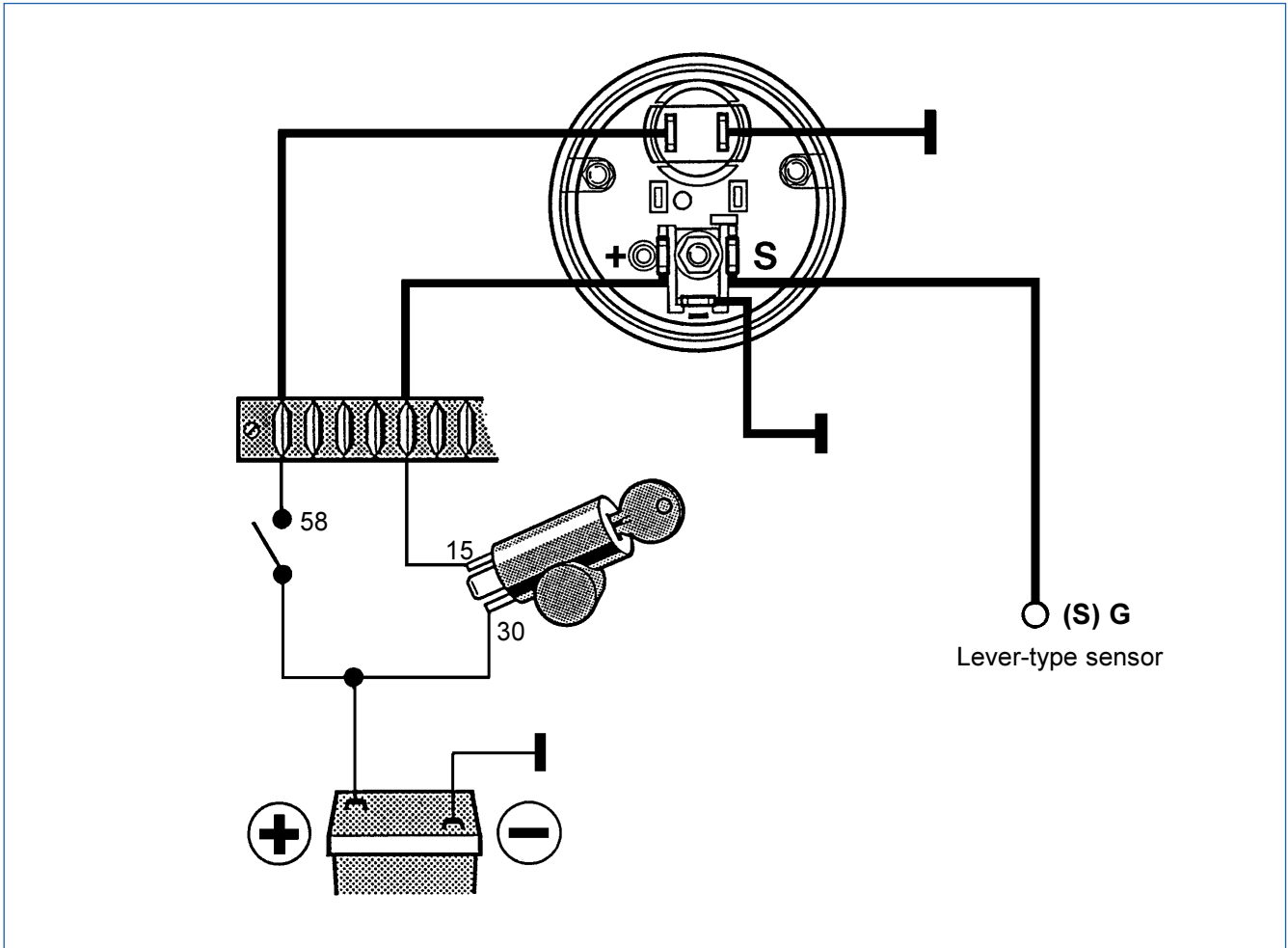

Technical Product Manual

VDO cockpit vision VDO cockpit international

8. Electric Fuel Level Gauge (dia. 52mm) (Fuel Level Sensor, Lever-Type)

8.5 Testing Instructions

Test accessories

1x power supply	} contained in test kit X12-019-101-001
1x test cable No. 3	
1x measuring cable	
1x resistor decade	

Connector pin allocation

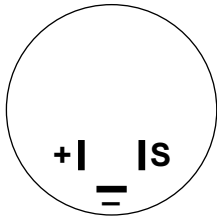

Pin + + 12V or + 24V
Pin - Ground
Pin S Sensor signal input

Test circuit diagram

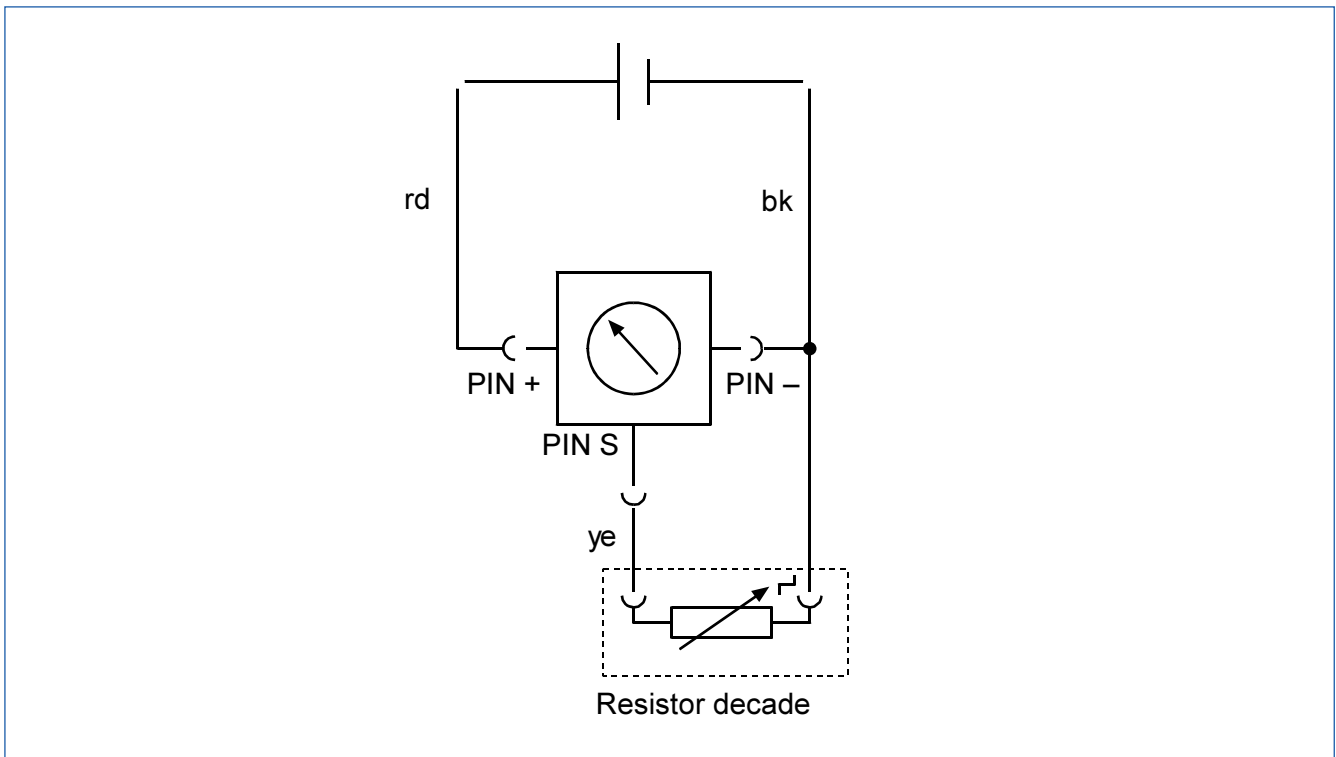

Test method description

Basic setting:	12 V instruments	»»»»»	14 V
	24 V instruments	»»»»»	28 V

Start the pointer position test with the highest resistance value!

Technical Product Manual

VDO cockpit vision VDO cockpit international

8. Electric Fuel Level Gauge (dia. 52mm) (Fuel Level Sensor, Lever-Type)

8.5 Testing Instructions

Test of the movement

Connect the instrument according to the test circuit diagram, using test cable 3.

The indication can be tested with the resistor decade 'sensor simulator'.

The pointer moves to full scale deflection if the resistor decade is not connected.

The following table shows the resistance values and the permissible indication tolerances in angular degrees.

Indication	0	1/4	1/2	3/4	1/1
Resistance (Ω)	3	45	85	138	180
Deflection ($^\circ\angle$)	0	17.2	41.2	73.8	88.8
Tolerance ($^\circ\angle$)	+ 3.6 - 3.6	\pm 3.6	\pm 3.6	\pm 3.6	+ 3.6 - 3.6

Technical Product Manual



VDO cockpit vision VDO cockpit international

8. Electric Fuel Level Gauge (dia. 52mm) (Fuel Level Sensor, Lever-Type)

8.6 Instruments Survey

VDO cockpit vision (Backlight) dia. 52 mm

Part No. 301-010-...

Dial		Special feature	No.
Range	Imprint		
0 ... 1/1	0 - 1/2 - 1/1 	Clamp ring 12 V Lever-type	002K
0 ... 1/1	0 - 1/2 - 1/1 	Stud bolts 12 V Lever-type	008K

Part No. 301-020-...

Dial		Special feature	No.
Range	Imprint		
0 ... 1/1	0 - 1/2 - 1/1 	Clamp ring, lever-type 24 V without colour caps	001C

VDO cockpit international (Floodlight) dia. 52 mm

Part No. 301-030-...

Dial		Special feature	No.
Range	Imprint		
0 ... 1/1	0 - 1/2 - 1/1 	Lever-type 12 V	001C 001G

Part No. 301-040-...

Dial		Special feature	No.
Range	Imprint		
0 ... 1/1	0 - 1/2 - 1/1 	Lever-type 24 V	001C 001G

Technical Product Manual

VDO cockpit vision VDO cockpit international

9. Electric Fuel Level Gauge (dia. 52 mm) (Fuel Level Sensor, Tubular Type)

Contents	Page
9.1 General informations	9 - 2
9.2 Technical data	9 - 4
9.3 Tubular type sensors	9 - 6
9.4 Wiring diagram	9 - 8
9.5 Adjustment	9 - 9
9.6 Testing instructions	9 -10
9.7 Instruments survey	9 -12

Installation instructions

999-161-020: VDO cockpit vision
999-161-018: VDO cockpit international

See file 'Installation Instructions (MA)'.

Technical Product Manual

VDO cockpit vision VDO cockpit international

9. Electric Fuel Level Gauge (dia. 52 mm) (Fuel Level Sensor, Tubular Type)

9.1 General Informations

The electric fuel level gauge has been designed for land-bound vehicles or stationary systems only (exception: motorcycles).

The instrument has an analog tank fuel level display graduated in fuel levels.
Tubular type sensors of various types can be used as sensors.

The instrument is adjusted by a potentiometer on the side of the instrument housing (see chapter 9.5).



The lamp socket is clipped in.
To replace the light bulb, carefully, with the thumb,
push the lamp holder out to the side.

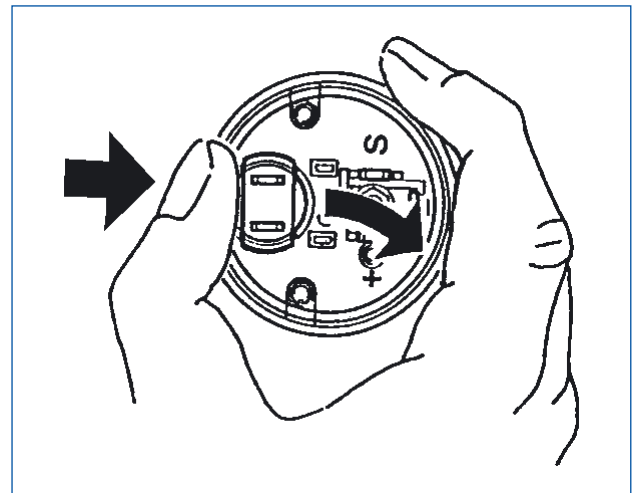

Technical Product Manual

VDO cockpit vision VDO cockpit international

9. Electric Fuel Level Gauge (dia. 52 mm) (Fuel Level Sensor, Tubular Type)

9.1 General Informations

Designation of function

Movement: System Ke (90°)

(Turning magnet movement for ratio indication, maximum pointer travel 90°)

The fuel reserve indicator applies the resistance measurement principle. A sensor (tubular type) in the liquid at the measuring point converts the liquid reserve to a corresponding resistance value. A turning magnet ratio measuring movement measures this resistance value.

It comprises three stationary coils wound at 90° against each other, and a rotating permanent magnet disk in these coils. The coils are connected to determine a ratio, so that the instrument is insensitive to on-board voltage fluctuations. This means that the pointer travel is only determined by the magnitude of the current flowing through the measuring system.

A magnetic shield prevents effects of external magnetic fields, indication errors due to temperature changes are corrected by a compensating resistor.

A dropping resistor is used to adapt the measuring movement to higher operating voltages (e. g. 24V).

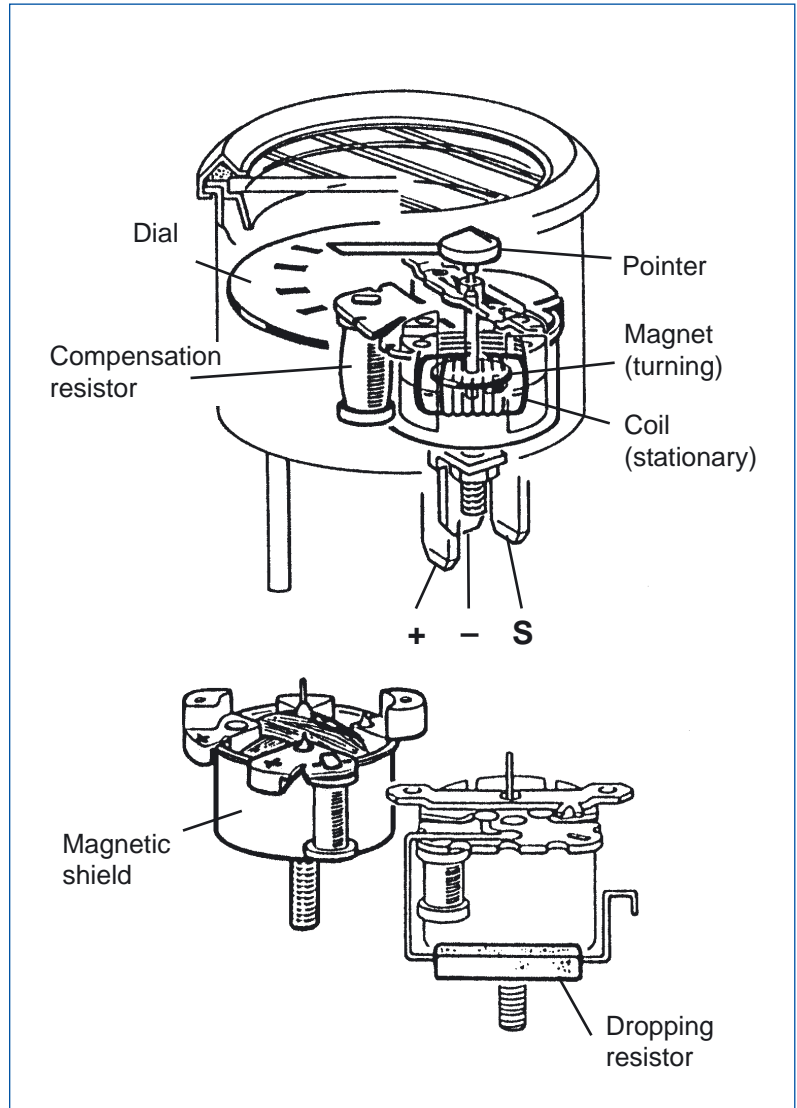

Technical Product Manual

VDO cockpit vision VDO cockpit international

9. Electric Fuel Level Gauge (dia. 52 mm) (Fuel Level Sensor, Tubular Type)

9.2 Technical Data

Operating voltage:	11 ... 16 V or 21.5 ... 30 V
Movement:	System Ke (90°)
Current consumption:	96 mA (without illumination)
Operating temp.:	- 30°C ... + 85°C
Storage temperature:	- 40°C ... + 90°C
Illumination:	1 light bulb 14 V, 3.4 W or 24 V, 3 W, 2 coloured caps, green and red (only at 12 V)
Protection:	IP64 DIN 40050 from the front reverse-polarity protection
Vibration resistance:	max. 1g eff., 25 ... 2000 Hz, duration 8 h, f: 1 octave/min.
Nominal position:	NL 0 to NL 90, DIN 16257

VDO cockpit vision
dia. 52 mm Backlight



Potentiometer
empty: 60Ω ... 90Ω sensor resistor

Sensor: tubular type sensor
(not included)

Mounting hole: dia. 53mm

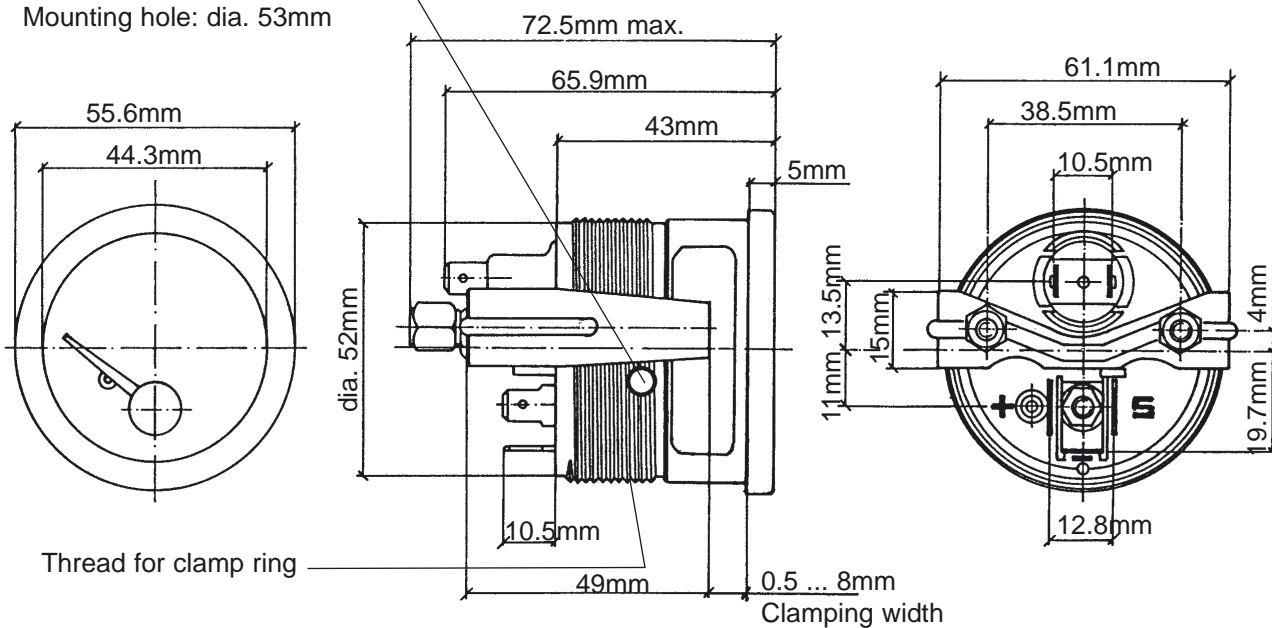

Thread for clamp ring

0.5 ... 8mm
Clamping width

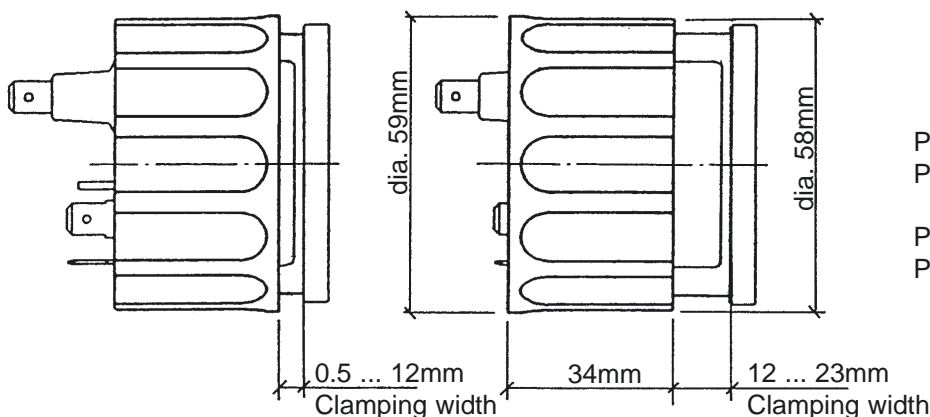

Pin assignment:
Pin +: + 12 V or + 24 V
terminal 15
Pin -: Ground, terminal 31
Pin S: Sensor

Technical Product Manual

VDO cockpit vision VDO cockpit international

9. Electric Fuel Level Gauge (dia. 52 mm) (Fuel Level Sensor, Tubular Type)

9.2 Technical Data

Operating voltage:	11 ... 16 V or 21.5 ... 30 V
Movement:	System Ke (90°)
Current consumption:	96 mA (without illumination)
Operating temp.:	- 30°C ... + 85°C
Storage temperature:	- 40°C ... + 90°C
Illumination:	1 light bulb 14 V, 3.4 W oder 24 V, 3 W
Protection:	IP64 DIN 40050 from the front reverse-polarity protection
Vibration resistance:	max. 1g eff., 25 ... 2000 Hz, duration 8 h, f: 1 octave/min.
Nominal position:	NL 0 to NL 90, DIN 16257

VDO cockpit international
dia. 52 mm Floodlight



Mounting hole: dia. 53mm

Sensor: tubular type
(not included)

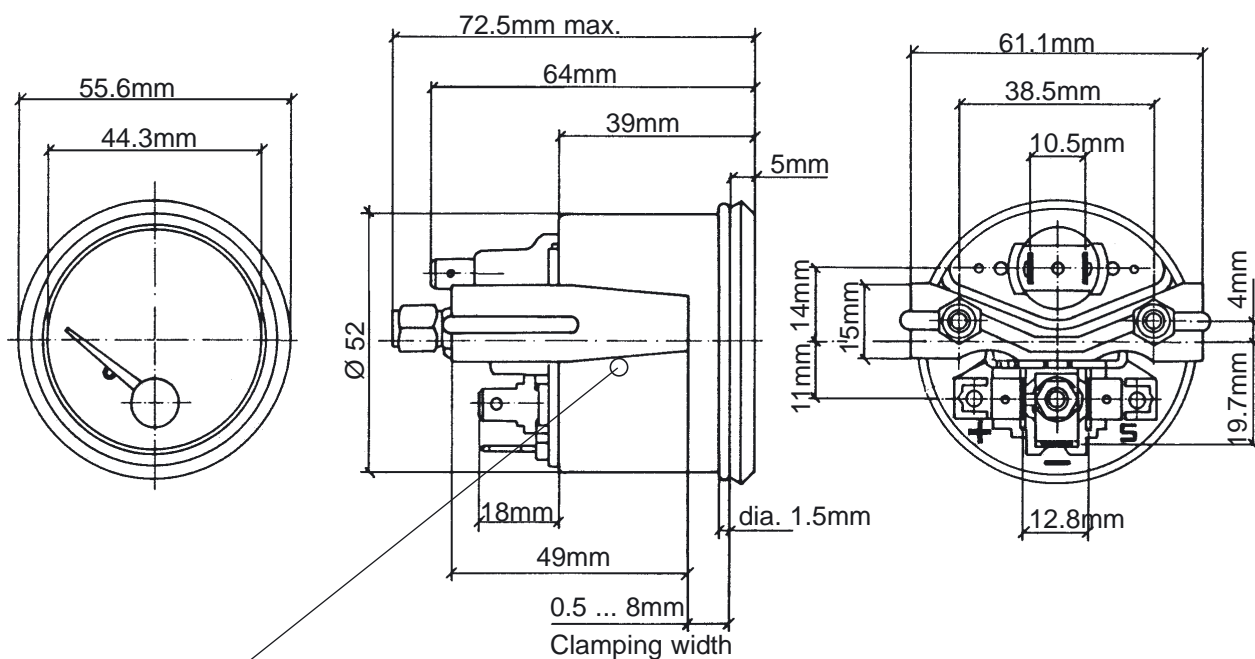

Potentiometer
empty: 60Ω ... 90Ω sensor resistor

Pin assignment:
Pin +: + 12 V or + 24 V
terminal 15
Pin -: Ground, terminal 31
Pin S: Sensor

Technical Product Manual

VDO cockpit vision VDO cockpit international

9. Electric Fuel Level Gauge (dia. 52 mm) (Fuel Level Sensor, Tubular Type)

9.3 Tubular Type Fuel Level Sensors

The tubular type fuel level sensor needed to operate the instrument is not included with the instrument.

Tubular type fuel level sensors with flange, hole circle dia. 54mm or 80mm, or special flange (see data sheets for sensors) can be used.

The sensor is installed in a mounting hole made in the tank at a good position for fuel measurement, or on a mounting flange provided by the tank manufacturer, or in an existing mounting hole.

Tubular type fuel level sensor with flange, hole circle dia. 54 mm

This metal sensor (6 V to 24 V, negative earth) is available in different lengths.

Accessories:

screw-fixation tank flange with sealing and mounting parts
or
weld-type tank flange,
sealing,
mounting parts.

Tubular type fuel level sensor with flange, hole circle dia. 80 mm

This metal sensor (6 V to 24 V, negative earth or insulated earth) is available in different lengths.

Accessories:

weld-type tank flange,
sealings,
mounting parts.

Tubular type fuel level sensor with special flange

This metal sensor (6 V to 24 V, negative earth or insulated earth) with special flange (bayonet flange, thread flange or special type flange) is available in different lengths.

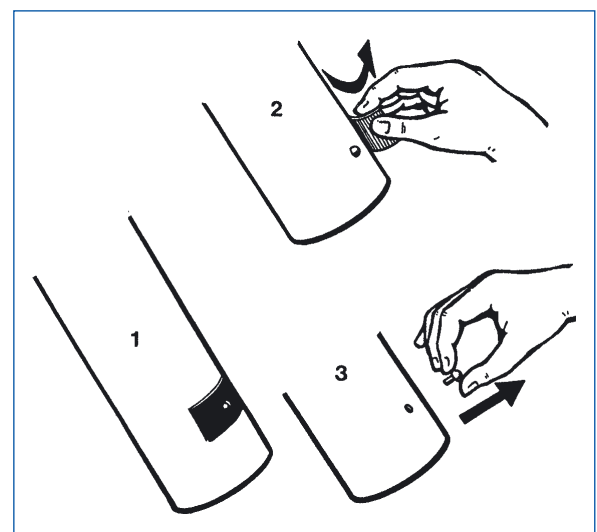
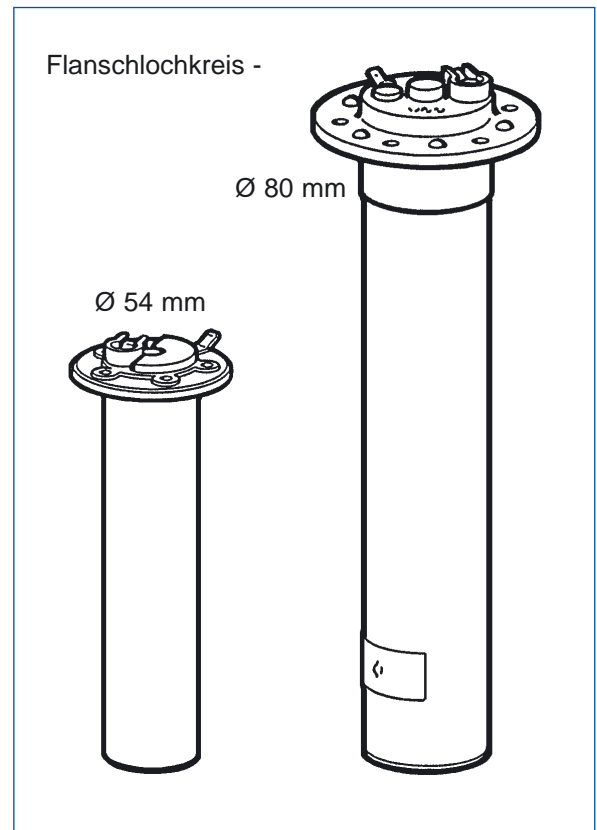

Prior to installation remove the adhesive tape on the dip tube and the float retaining pin.

Technical Product Manual

VDO cockpit vision VDO cockpit international

9. Electric Fuel Level Gauge (dia. 52 mm) (Fuel Level Sensor, Tubular Type)

9.3 Tubular Type Fuel Level Sensors

Installation informations for tubular type sensor (flange hole circle dia. 54 mm)
with a tank flange for screw fixation

If an installation opening must be made, the tank must be completely drained first.
Fill the fuel into an approved container.
Comply with the safety instructions of the automobile manufacturer for any work
performed under the automobile.

 Risk of explosion exists due to presence of residual gases in the tank!
Make sure that the tank is aired sufficiently (approx. 10 minutes).

Make a preliminary hole in the installation opening using a drill and then finish the hole
using a compass saw or piercing saw. Comply with the safety instructions of the tool
manufacturer. Clean the tank of residue from the drilling or sawing work.

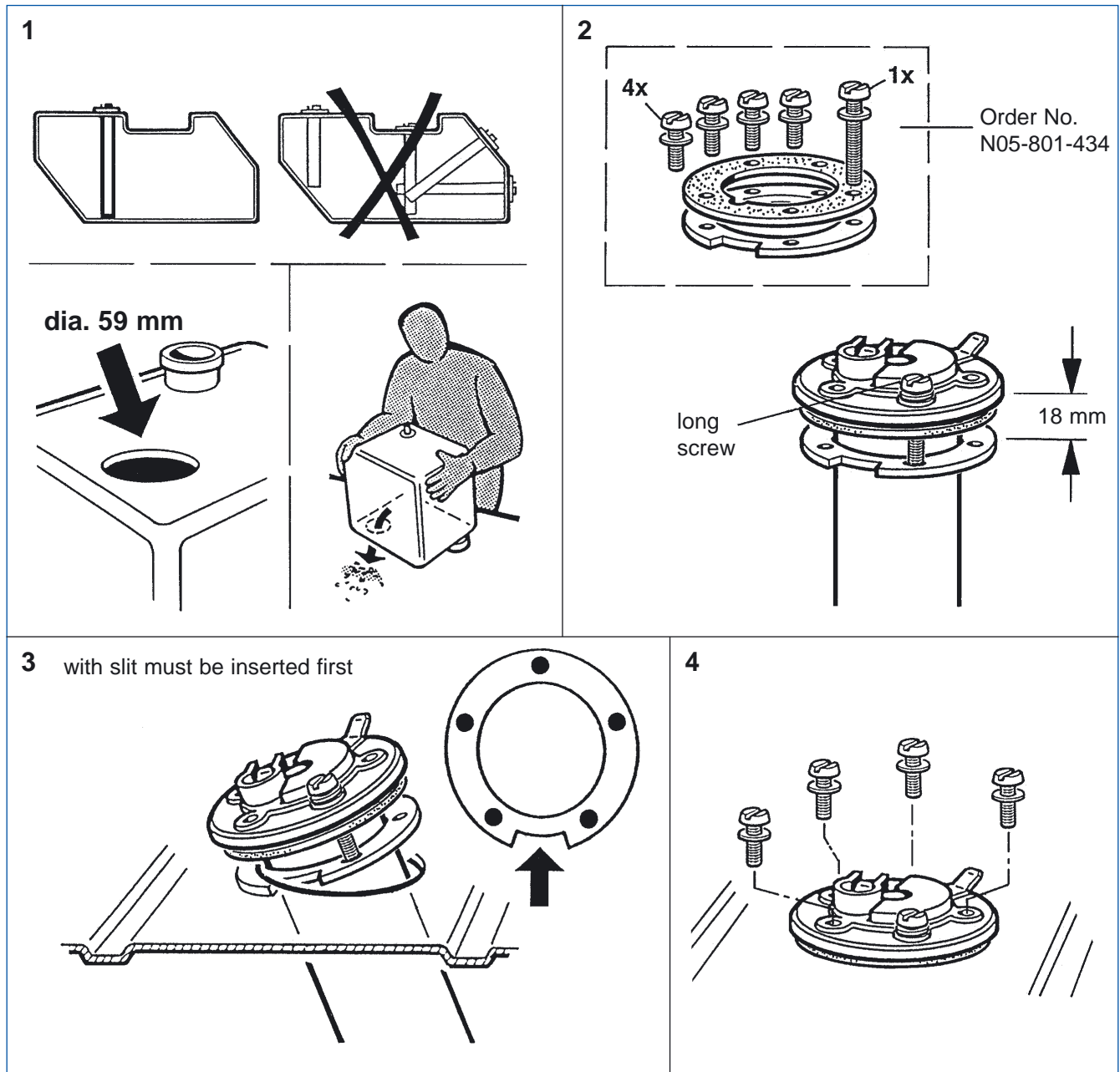

Technical Product Manual

VDO cockpit vision VDO cockpit international

9. Electric Fuel Level Gauge (dia. 52 mm) (Fuel Level Sensor, Tubular Type)

9.4 Wiring Diagram

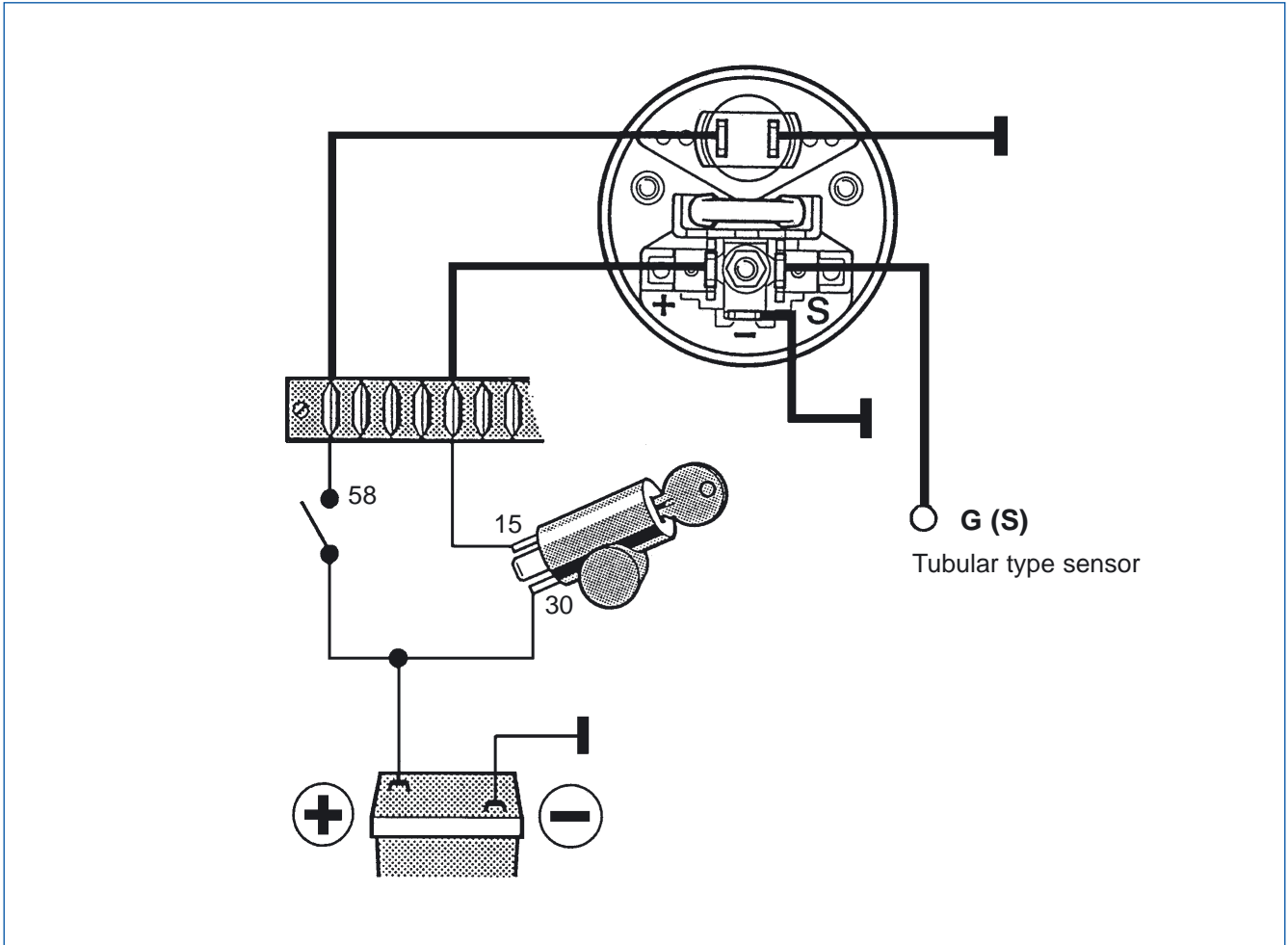

Technical Product Manual

VDO cockpit vision VDO cockpit international

9. Electric Fuel Level Gauge (dia. 52 mm) (Fuel Level Sensor, Tubular Type)

9.5 Adjustment

Indicating instrument and sensor must be adjust as a matched pair
(in the sensor resistor range from 60Ω to 90Ω).

 Make adjustment with empty tank.

Adjust indicating instrument by potentiometer on the side of the instrument housing to set the pointer to zero.
Use an insulated screwdriver.

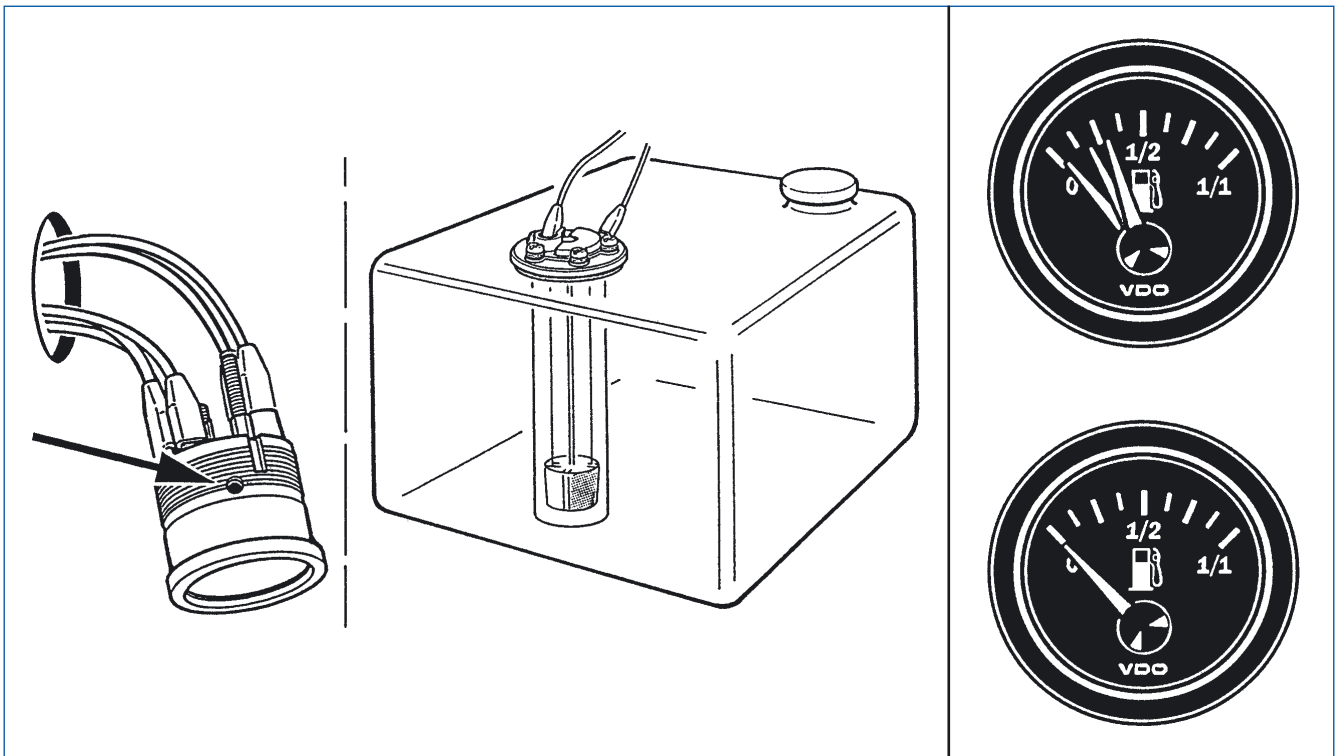

Technical Product Manual

VDO cockpit vision VDO cockpit international

9. Electric Fuel Level Gauge (dia. 52 mm) (Fuel Level Sensor, Tubular Type)

9.6 Testing Instructions

Test accessories

- 1x power supply
- 1x test cable No. 3
- 1x measuring cable
- 1x resistor decade

} contained in test cables kit
X12-019-101-001

Pin allocation

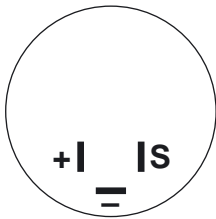

Pin + + 12V or + 24V
Pin - Ground
Pin S Sensor signal input

Test circuit diagram

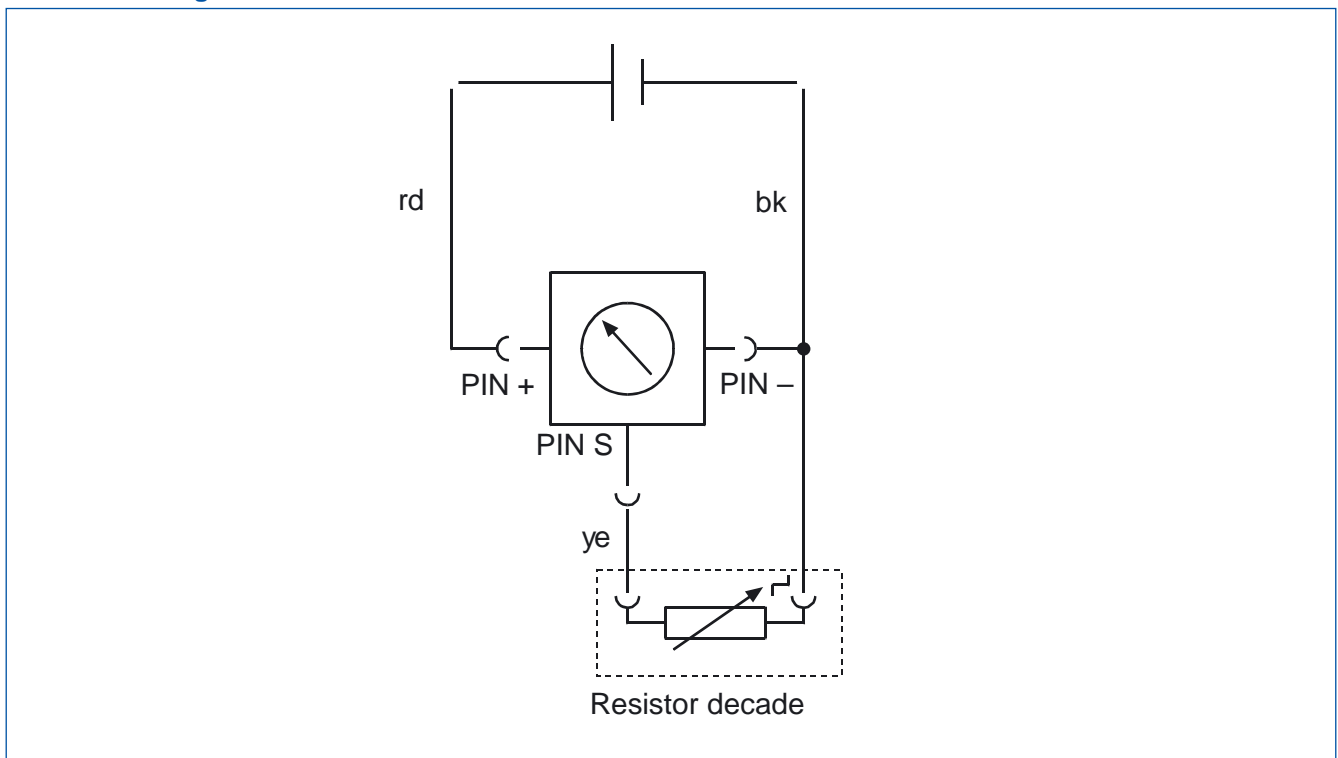

Test metho description

Basic settings:	12 V instruments	→	14 V
	24 V instruments	→	28 V

Start the pointer position test with the lowest resistance value!

Technical Product Manual

VDO cockpit vision VDO cockpit international

9. Electric Fuel Level Gauge (dia. 52 mm) (Fuel Level Sensor, Tubular Type)

9.6 Testing Instructions

Test of the movement

Connect the instrument according to the test circuit diagram, using test cable 3.

The indication can be tested with the resistor decade 'sensor simulator'.

The following table shows the resistance values and the permissible indication tolerances in angular degrees.

Indication	0	¼	½	¾	1/1
Resistance (Ω)	60 ... 90				0.5
Deflection (°)	0	24	48	67	87.5
Tolerance (°)	+ 3.6 - 3.6				+ 3.6 - 3.6

Technical Product Manual



VDO cockpit vision VDO cockpit international

9. Electric Fuel Level Gauge (dia. 52 mm) (Fuel Level Sensor, Tubular Type)

9.7 Instrument Survey

VDO cockpit vision (Backlight) dia. 52 mm

Part No. 301-010-...

Dial		Special feature	Part No.
Range	Imprint		
0 ... 1/1	0 - 1/2 - 1/1 	adjustable, clamp ring tubular type 12 V	001K
0 ... 1/1	0 - 1/2 - 1/1 	adjustable, stud bolts tubular type 12 V	007K

Part No. 301-020-...

Dial		Special feature	Part No.
Range	Imprint		
0 ... 1/1	0 - 1/2 - 1/1 	adjustable, clamp ring, 24 V tubular type, w without colour caps	002C

VDO cockpit international (Floodlight) dia. 52 mm

Part No. 301-030-...

Dial		Special feature	Part No.
Range	Imprint		
0 ... 1/1	0 - 1/2 - 1/1 	adjustable tubular type 12 V	002C 002G

Part No. 301-040-...

Dial		Special feature	Part No.
Range	Imprint		
0 ... 1/1	0 - 1/2 - 1/1 	adjustable tubular type 24 V	002C 002G

Technical Product Manual

VDO cockpit vision VDO cockpit international

10. Voltmeter (dia. 52 mm)

Contents	Page
10.1 General informations	10 - 2
10.2 Technical data	10 - 4
10.3 Wiring diagram	10 - 6
10.4 Testing instructions	10 - 7
10.5 Instruments survey	10 - 8

Installation instructions

999-161-009: VDO cockpit vision
999-161-001: VDO cockpit international

See file 'Installation Instructions (MA)'.

Technical Product Manual

VDO cockpit vision VDO cockpit international

10. Voltmeter (dia. 52 mm)

10.1 General Informations

The voltmeter has been designed for land-bound vehicles or stationary systems only (exception: motorcycles).

The instrument has an analog display indicating the vehicle voltage in Volt.



The lamp socket is clipped in.

To replace the light bulb, carefully, with the thumb, push the lamp holder out to the side.

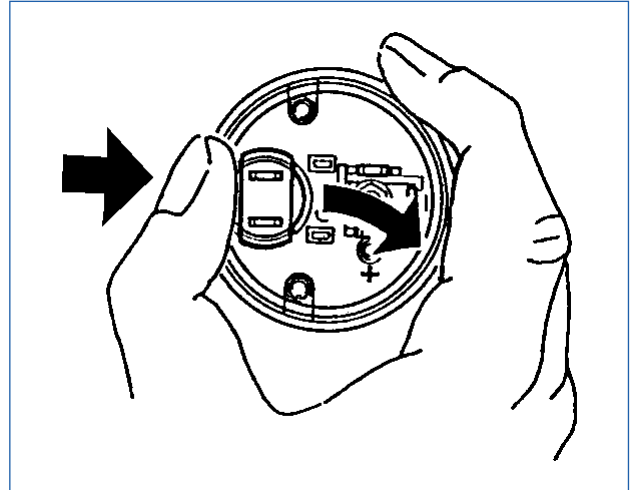

Technical Product Manual

VDO cockpit vision VDO cockpit international

10. Voltmeter (dia. 52 mm)

10.1 General Informations

Designation of function

Movement: System Ke (90°)

(Turning magnet movement for ratio indication, maximum pointer travel 90°)

The voltmeter is connected to the plus and minus (ground) polarity for voltage display. A turning magnet ratio measuring movement is used. The dial is graduated according to the movement characteristic. The voltage range to be ignored, below 8 V or 18 V, is electronically suppressed by a Z diode. The limitation of the dial to a range of 8 - 16 V or 18 - 32 V (instead of 0 - 16 V or 0 - 32 V for the same pointer deflection) gives a better resolution of the reading.

The turning magnet ratio measuring movement comprises three stationary coils wound at 90° against each other, and a rotating permanent magnet disk with an axle and a pointer in these coils.

The three coils constitute two measuring circuit branches, coil III constituting branch 1; branch 2 consists of coil II with opposite sense of winding and coil I wound vertical to coil II.

No current passes the Z diode between voltage 0 and Z voltage, the current distribution in all three coils is unchanged, and thus the resulting magnetic field remains unchanged.

A partial current passes the Z diode when the voltage rises above the minimum value indicated on the dial. Now the currents in both circuit branches are not equal any more. The strength of the magnetic field in measuring circuit 1 containing coil III increases with the measured voltage, whereas it remains constant in measuring circuit 2 with coils I and II. The turning magnet carrying the pointer follows the direction of the field resulting from measuring circuits 1 and 2, thereby indicating the measured voltage.

A magnetic shield prevents effects of external magnetic fields.

The voltmeter measuring range is adapted to various on-board voltages by selection of adequate dropping resistor and Z diode values.

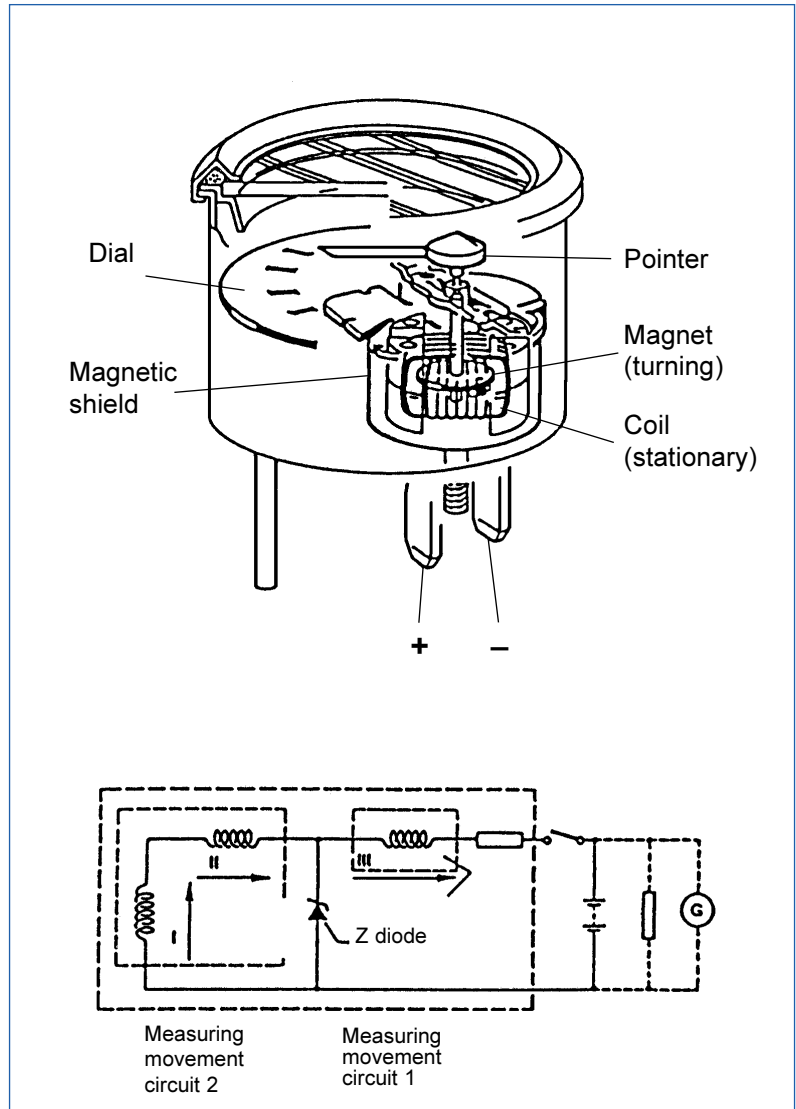

Technical Product Manual

VDO cockpit vision VDO cockpit international

10. Voltmeter (dia. 52 mm)

10.2 Technical Data

Operating voltage:	8 ... 16 V or 18 ... 32 V
Movement:	System Ke (90°)
Current consumption:	67 mA = 16 V (without illumination) 63 mA = 32 V (without illumination)
Operating temp.:	- 30°C ... + 85°C
Storage temperature:	- 40°C ... + 90°C
Illumination:	1 light bulb 14 V, 3.4 W or 24 V, 3 W, 2 coloured caps, green and red (only at 12 V)
Protection:	IP64 DIN 40050 from the front reverse-polarity protection
Vibration resistance:	max. 1g eff., 25 ... 2000 Hz, duration 8 h, f: 1 octave/min.
Nominal position:	NL 0 to NL 90, DIN 16257

VDO cockpit vision
dia. 52 mm Backlight

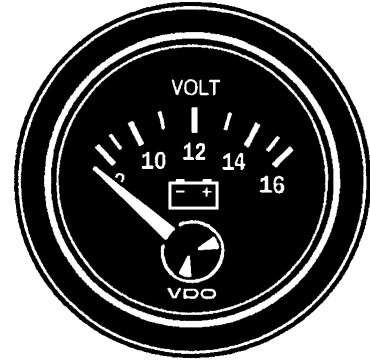

Example: voltmeter operating voltage 8 ... 16 V

Mounting hole: dia. 53mm

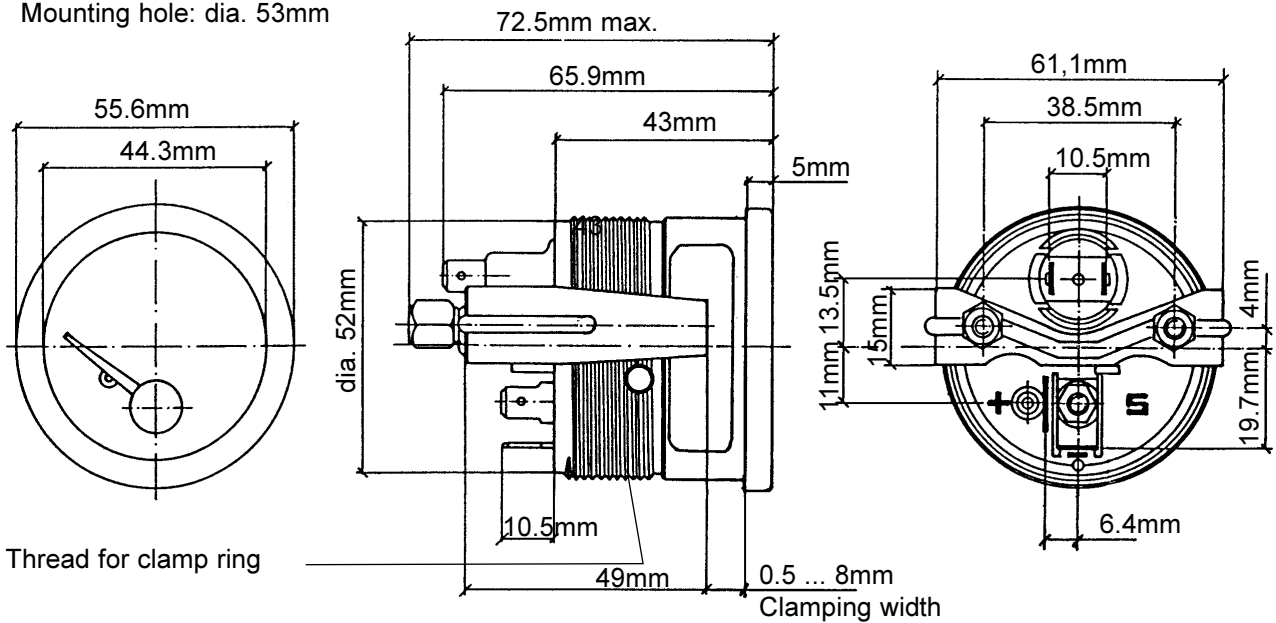

Thread for clamp ring

0.5 ... 8mm Clamping width

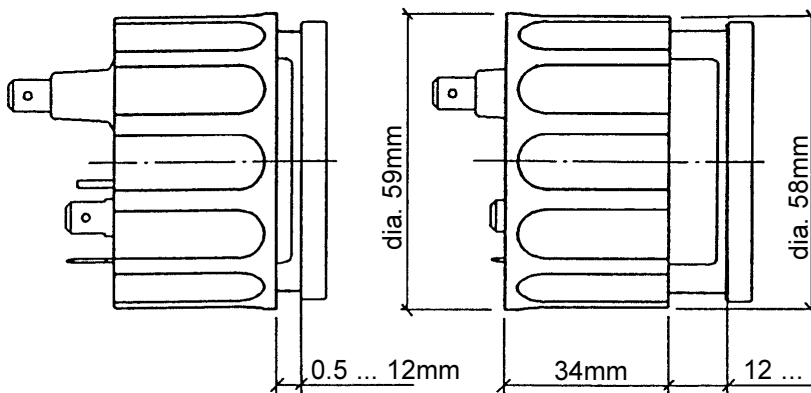

Pin assignment:

Pin +: + 12 V or + 24 V, terminal 15

Pin -: Ground, terminal 31

Pin S: not assigned

Technical Product Manual

VDO cockpit vision VDO cockpit international

10. Voltmeter (dia. 52 mm)

10.2 Technical Data

Operating voltage:	8 ... 16 V or 18 ... 32 V
Movement:	System Ke (90°)
Current consumption:	67 mA = 16 V (without illumination) 63 mA = 32 V (without illumination)
Operating temp.:	- 30°C ... + 85°C
Storage temperature:	- 40°C ... + 90°C
Illumination:	1 light bulb 14 V, 3.4 W or 24 V, 3 W
Protection:	IP64 DIN 40050 from the front reverse-polarity protection
Vibration resistance:	max. 1g eff., 25 ... 2000 Hz, duration 8 h, f: 1 octave/min.
Nominal position:	NL 0 to NL 90, DIN 16257

VDO cockpit international
dia. 52 mm Floodlight

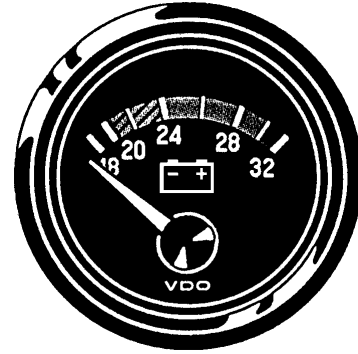

Example: voltmeter
operating voltage 18 ... 32 V

Mounting hole: dia. 53mm

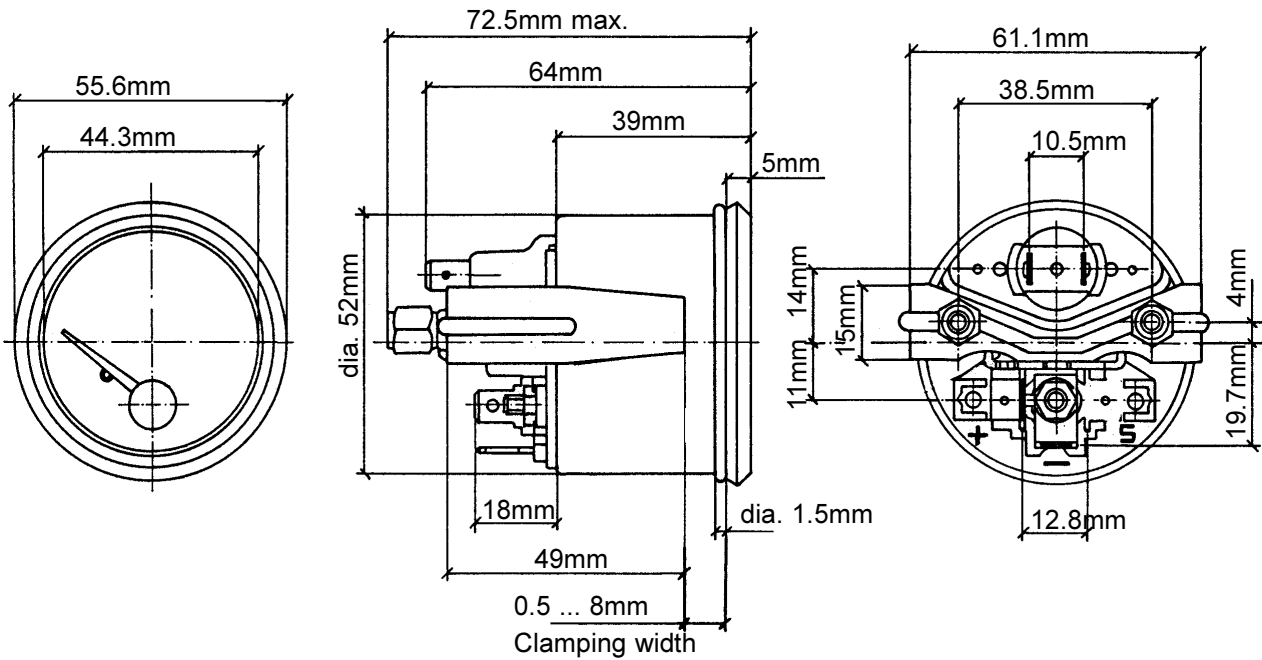

Pin assignment:

Pin +: + 12 V or + 24 V,
terminal 15

Pin -: Ground, terminal 31

Pin S: not assigned

Technical Product Manual

VDO cockpit vision VDO cockpit international

10. Voltmeter (dia. 52 mm)

10.3 Wiring Diagram

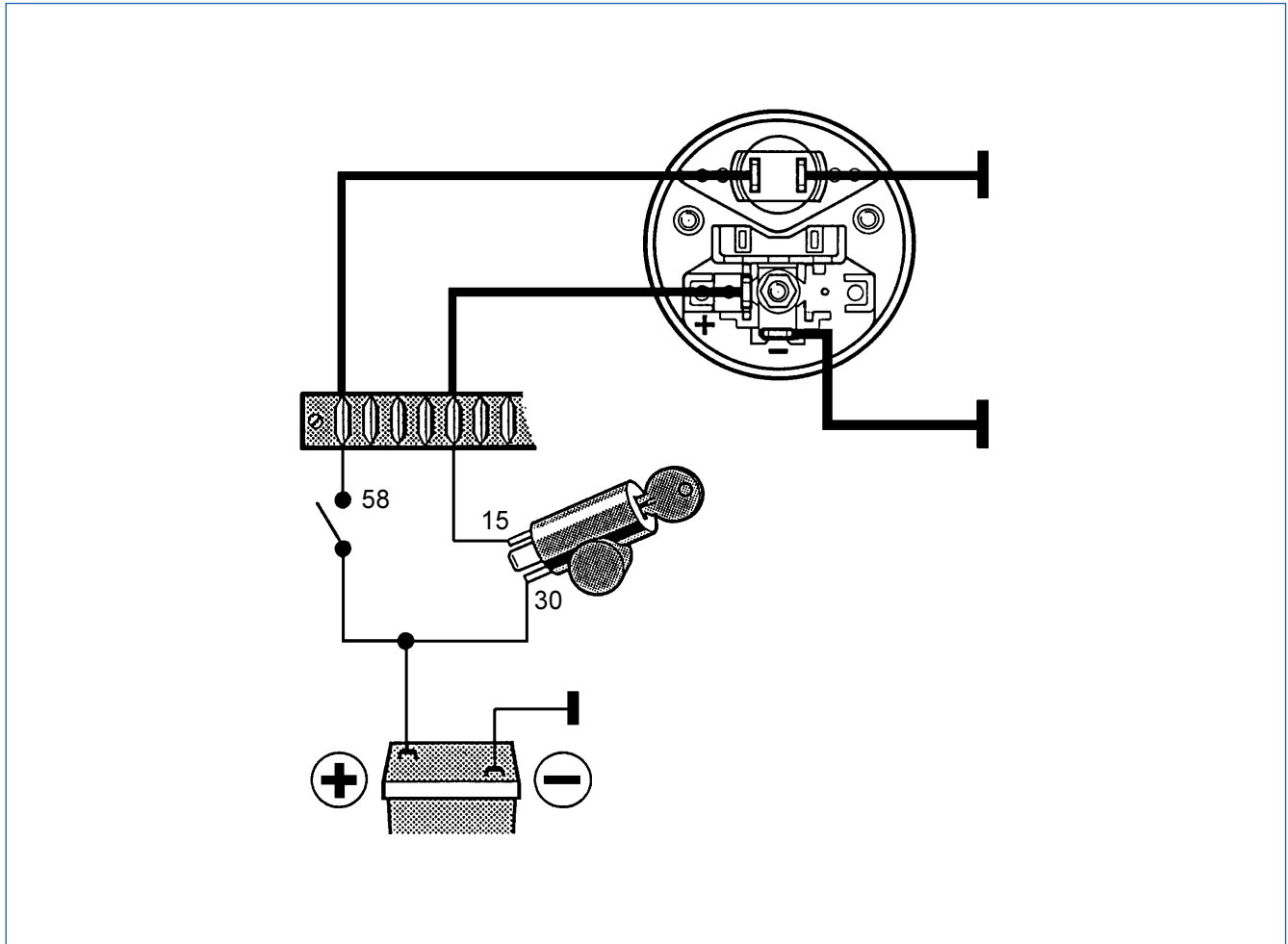

Technical Product Manual

VDO cockpit vision VDO cockpit international

10. Voltmeter (dia. 52 mm)

10.4 Testing Instructions

- Test accessories**
- 1x power supply
 - 1x test cable No. 3 } contained in test cables kit
 - 1x measuring cable } X12-019-101-001

Pin allocation

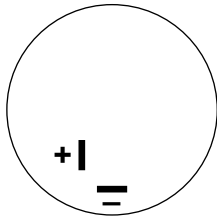

Pin + + 12V or + 24V
Pin - Ground

Test circuit diagram

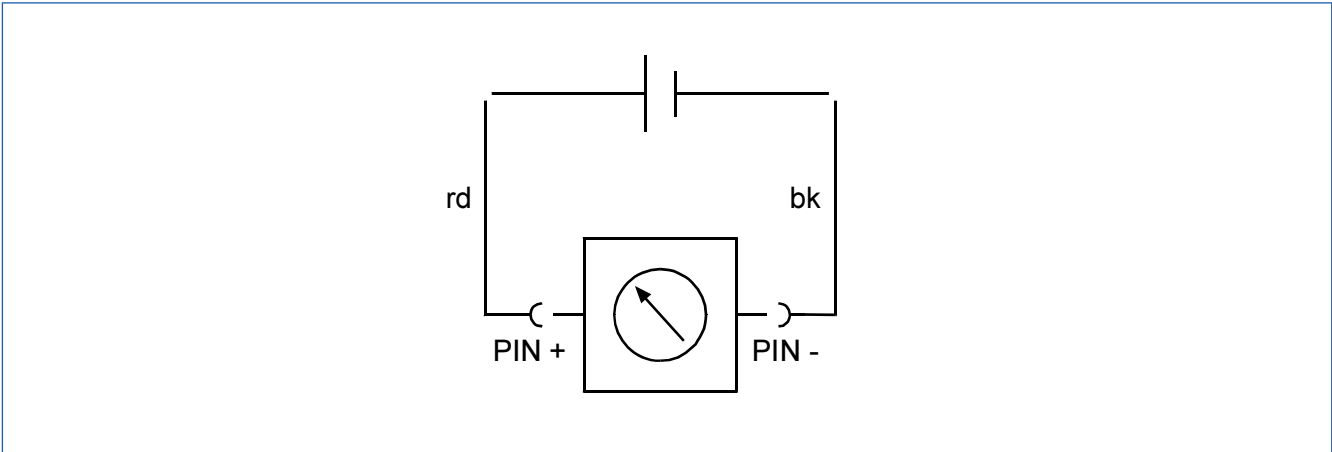

Test method description

Test of the movement

Connect the instrument according to the test circuit diagram, using test cable 3.

The following tables shows the permissible Volt indication tolerances in angular degrees.

Indication (V)	8	9	10	11	12	13	14	15	16
Deflection (°∠)	0	7.1	16.8	29.4	44.1	58.6	70.8	80.6	87.6
Tolerance (V)	± 0.85		± 0.6		± 0.5		± 0.5		± 0.75

Indication (V)	18	20	22	24	25	26	28	30	32
Deflection (°∠)	0	8.1	19	33.6	42.1	50.4	66.4	78.8	88
Tolerance (V)	± 0.85		± 0.6		± 0.5		± 0.5		± 0.75

Technical Product Manual



VDO cockpit vision VDO cockpit international

10. Voltmeter (dia. 52 mm)

10.5 Instruments Survey

VDO cockpit vision (Backlight) dia. 52 mm

Part No. 332-010-...

Dial		Special feature	Part No.
Range	Imprint		
8 ... 16 V	VOLT 	Clamp ring 12 V	001K
8 ... 16 V	VOLT 	Stud bolts 12 V	003K

Part No. 332-020-...

Dial		Special feature	Part No.
Range	Imprint		
18 ... 32 V	VOLT 	Clamp ring, 24 V without colour caps	001C

VDO cockpit international (Floodlight) dia. 52 mm

Part No. 332-030-...

Dial		Special feature	Part No.
Range	Imprint		
8 ... 16 V	Colour fields (red and green) 	12 V	001C 001G

Part No. 332-040-...

Dial		Special feature	Part No.
Range	Imprint		
18 ... 32 V	Colour fields (red and green) 	24 V	001C 001G

Technical Product Manual

VDO cockpit vision VDO cockpit international

11. Ammeter (dia. 52 mm)

Contents	Page
11.1 General informations	11 - 2
11.2 Technical data	11 - 5
11.3 Wiring diagram	11 - 9
11.4 Dropping resistor for 24V (only for type B)	11 - 11
11.5 Instruments survey	11 - 12

Installation instructions

Type A:

999-161-015: VDO cockpit vision

999-161-007: VDO cockpit international

Type B (150 Ampere):

—

See file 'Installation Instructions (MA)'.

Technical Product Manual

VDO cockpit vision VDO cockpit international

11. Ammeter (dia. 52 mm)

11.1 General Informations

The ammeter has been designed for land-bound vehicles only (with the exception of motorcycles).

The instrument has an analog display indicating the vehicle DC current in Ampere.

There are two versions:

type A: indicating instrument for 30 Ampere, 60 Ampere or 100 Ampere.

type B: indicating instrument for 150 Ampere (accessories: shunt and wiring kit).

Illumination type A



The lamp socket is clipped in.
To replace the light bulb, carefully, with the thumb, push the lamp holder out to the side.

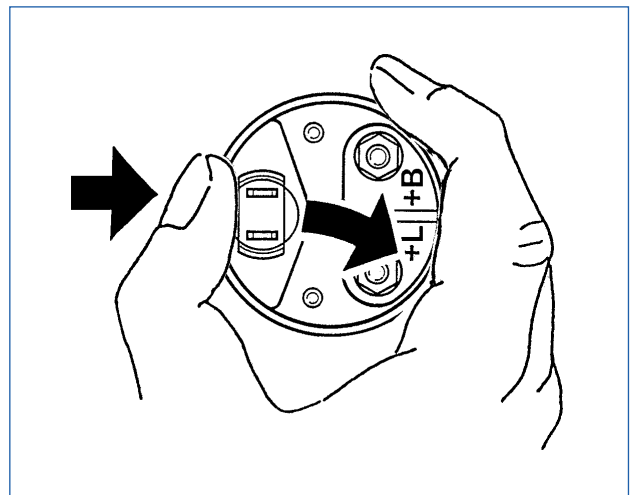

Illumination type B

The lamp socket is pushed in.
To replace the light bulb simple pull the lamp holder out.

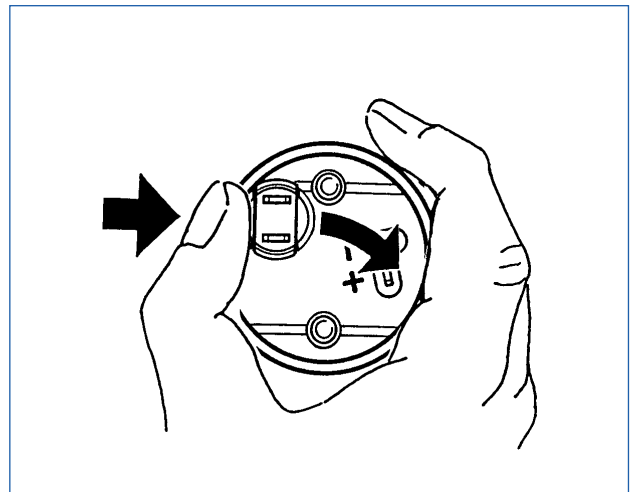

Technical Product Manual

VDO cockpit vision VDO cockpit international

11. Ammeter (dia. 52 mm)

11.1 General Informations

Designation of function for type A

The ammeter monitors charging and discharging currents in the on-board network.

For this function the ammeter is connected to the circuit so that charging currents and the load of all consumers, except the starter motor, must pass through the ammeter.

A rotating magnet disk is placed on top of the current-carrying bar. This disk is connected to a pointer, and turns as a function of the magnitude and direction of the current and the resulting magnetic field.

In static condition the pointer points to zero in the center of the graduation, the poles of the magnetic disk being directed to two neighboring calibration tags.

When the charging current increases, it produces a corresponding magnetic field around the conductor, which deflects the pointer from its zero position into the positive range. A discharge changes the direction of the current and of the resulting magnetic field. The inverse magnetic force deflects the magnetic disk with its pointer into the negative range.

The ammeter can be adjusted for different measuring ranges by adjustment of the calibration tags. A thicker current bar is used for measuring ranges of ± 50 A and more.

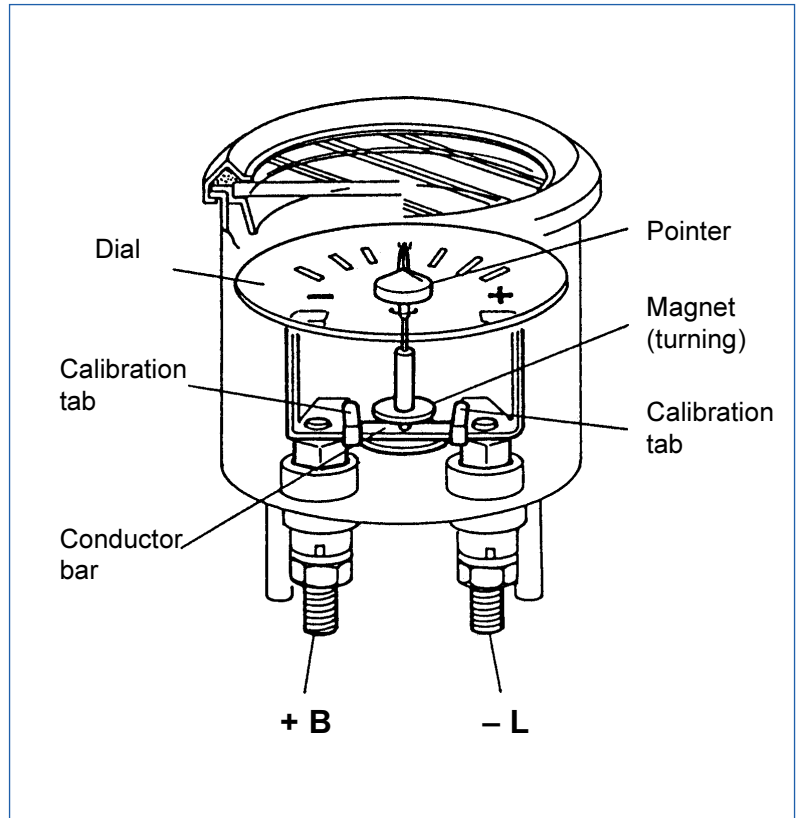

Technical Product Manual

VDO cockpit vision VDO cockpit international

11. Ammeter (dia. 52 mm)

11.1 General Informations

Designation of function for type B

Movement: System Ke (to 320°)

(Turning magnet ratio measuring movement, pointer deflection up to 320°)

The ammeter monitors charging and discharging currents in the on-board network.

A turning magnet ratio measuring movement is the main component of the ammeter. It converts the current pulses from the shunt to an analog display on a dial. An electronic circuit converts varying current pulses to unified pulses, which are fed to the turning magnet movement. The turning magnet ratio measuring movement applies the principle of the current ratio of two separate coils. Two stationary coils generate a magnetic field as a function of the current flowing through them. The magnetic field resulting from these two fields moves a two-pole magnet disk carrying a pointer. The pointer deflection is a function of the ratio of the two currents flowing through the coils.

A shielding casing prevents the effect of external magnetic fields.

The special electronic system controlling the movement permits a pointer deflection of 320°. The rotation is limited by a pin on the turning magnet moving in a groove of the coil carrier; the opposing force is generated by a spiral spring.

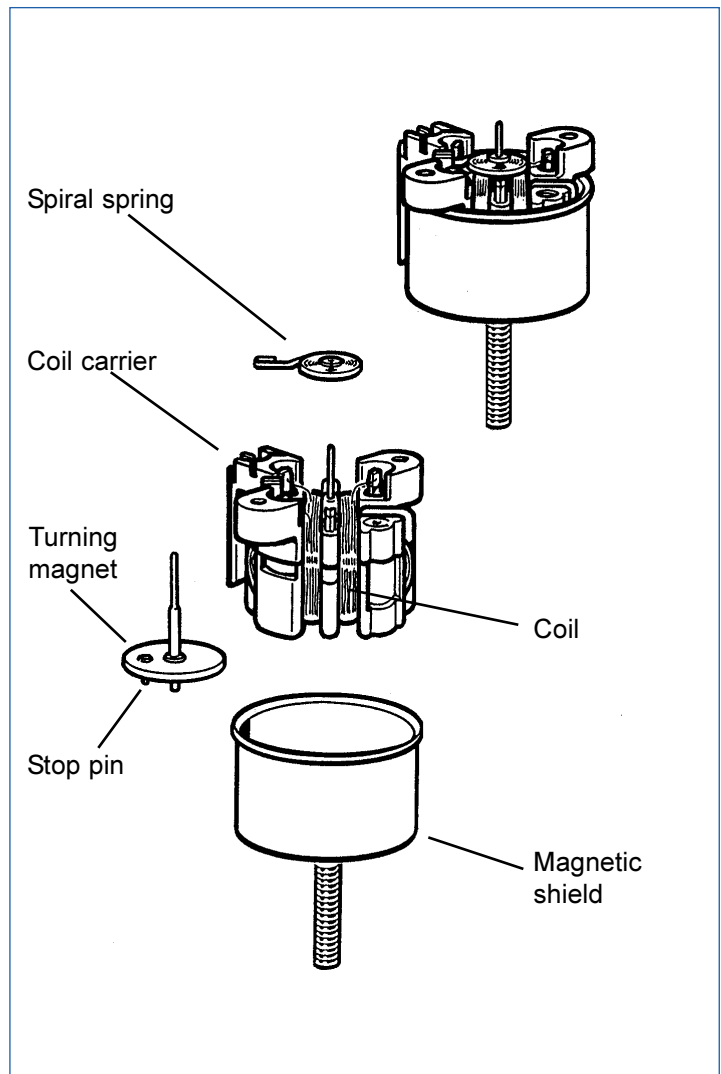

Technical Product Manual

VDO cockpit vision VDO cockpit international

11. Ammeter (dia. 52 mm)

11.2 Technical Data

Type A

Operating temperature:	- 30°C ... + 85°C
Storage temperature:	- 40°C ... + 90°C
Illumination:	1 light bulb 12 V, 2 W (option) or 24 V, 2 W, 2 colour caps, green and red
Protection:	IP64 DIN 40050 from the front
Vibration resistance:	max. 1g eff., 25 ... 2000 Hz, duration 8 h, f. 1 octave/min.
Nominal position:	NL 0 to NL 90, DIN 16257

VDO cockpit vision
dia. 52 mm Backlight

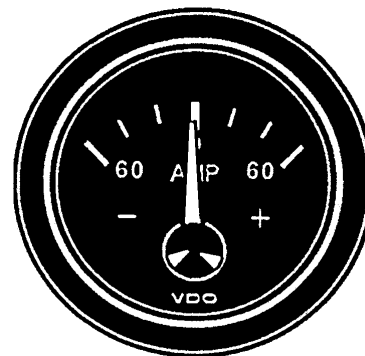

Mounting hole: dia. 53mm

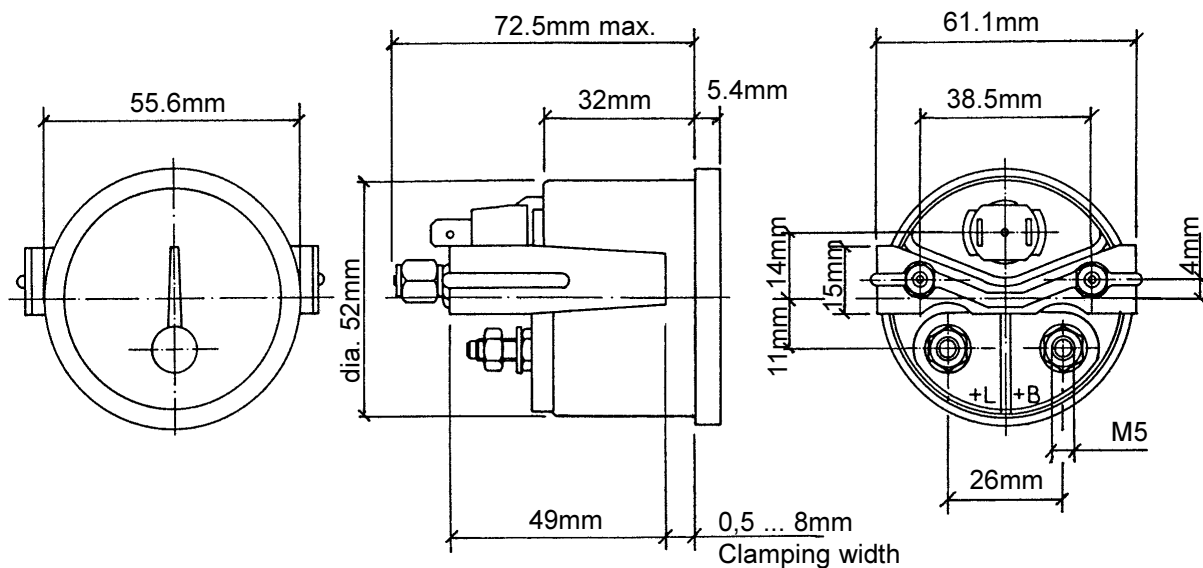

Pin assignment:

- + L: Alternator (terminal B+) and ignition switch (terminal 30)
- + B: + Battery (starter, terminal 30)

Technical Product Manual

VDO cockpit vision VDO cockpit international

11. Ammeter (dia. 52 mm)

11.2 Technical Data

Type A

Operating temperature:	- 30°C ... + 85°C
Storage temperature:	- 40°C ... + 90°C
Illumination:	1 Light bulb 12 V, 2 W or (option) 24 V, 2 W
Protection:	IP64 DIN 40050 from the front
Vibration resistance:	max. 1g eff., 25 ... 2000 Hz, duration 8 h, f. 1 octave/min.
Nominal position:	NL 0 to NL 90, DIN 16257

VDO cockpit international
dia. 52 mm Floodlight

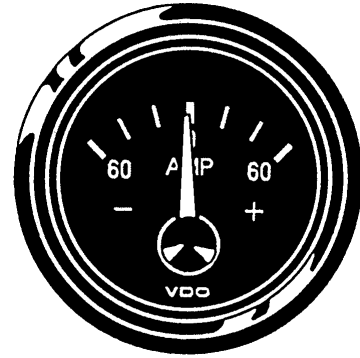

Mounting hole: dia. 53mm

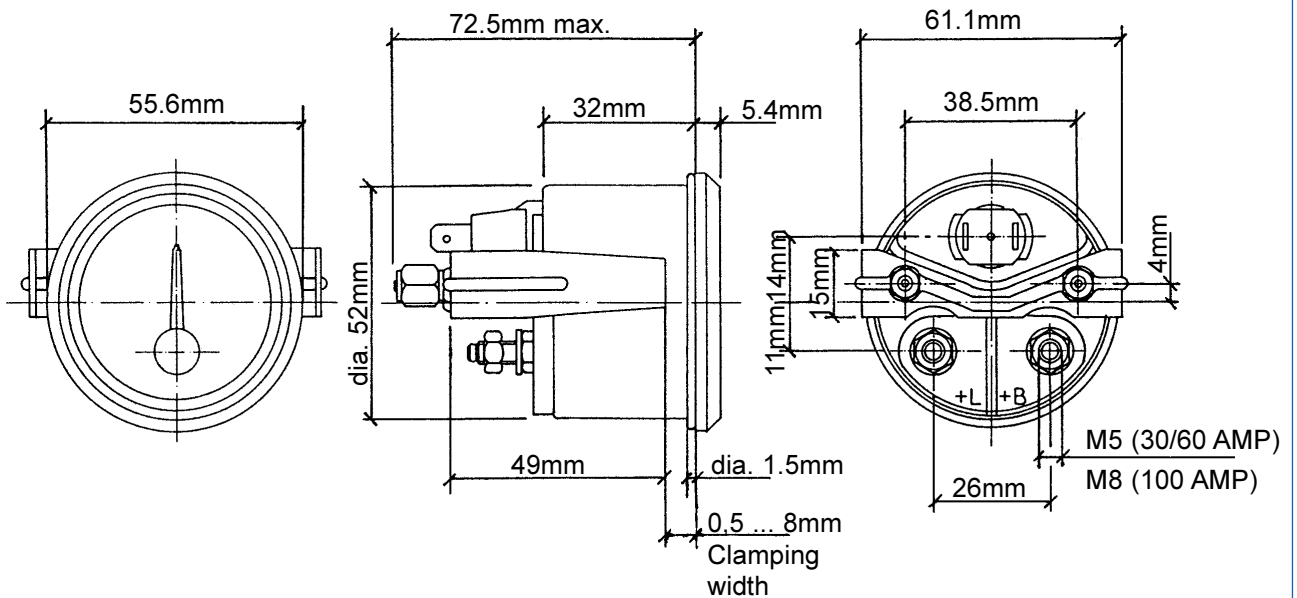

Pin assignment:

- + L: Alternator (terminal B+) and ignition switch (terminal 30)
- + B: + Battery (starter, terminal 30)

Technical Product Manual

VDO cockpit vision VDO cockpit international

11. Ammeter (dia. 52 mm)

11.2 Technical Data

Type B (150 Ampere): Indicating Instrument

Operating voltage:	10.8 V ... 16 V
Movement:	System Ke ($\rightarrow 320^\circ$)
Pickup:	Shunt (not included) 50 mV at max. deflection
Current consumption:	100 mA (without illumination)
Operating temperature:	$-20^\circ\text{C} \dots +70^\circ\text{C}$
Storage temperature:	$-30^\circ\text{C} \dots +85^\circ\text{C}$
Illumination:	1 light bulb 12 V, 2 W
Protection:	IP64 DIN 40050 from the front, CE approved, reverse-polarity protection
Vibration resistance:	max. 1g eff., 25 ... 2000 Hz, duration 8 h, f. 1 octave/min.

VDO cockpit international
dia. 52 mm Floodlight



Mounting hole: dia. 53mm

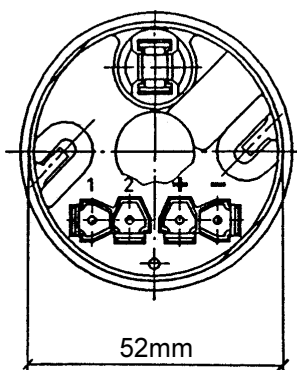

Pin assignment:

- 1: Signal +
- 2: Signal -
- +: Battery + (12 V)
- : Battery -

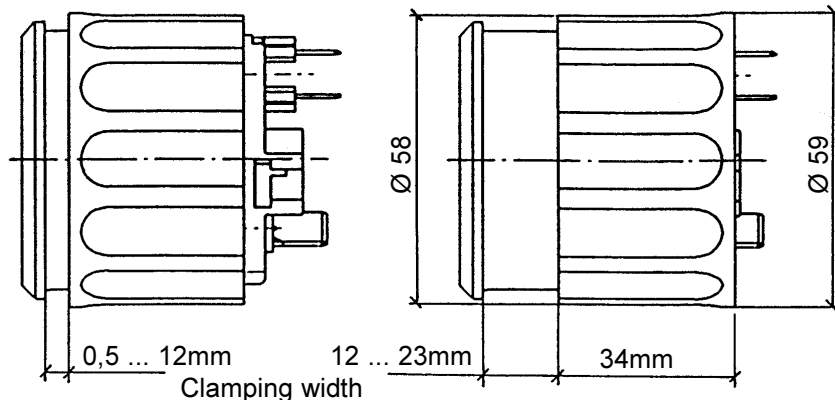
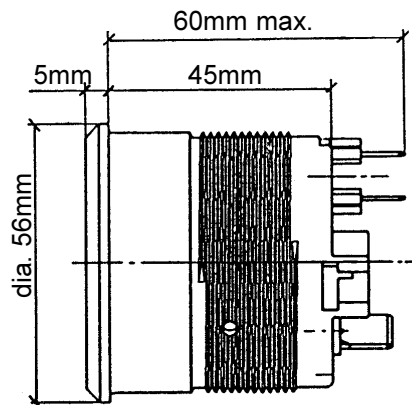

Technical Product Manual

VDO cockpit vision VDO cockpit international

11. Ammeter (dia. 52 mm)

11.2 Technical Data

Type B (150 Ampere): Accessories

VDO cockpit international

Shunt

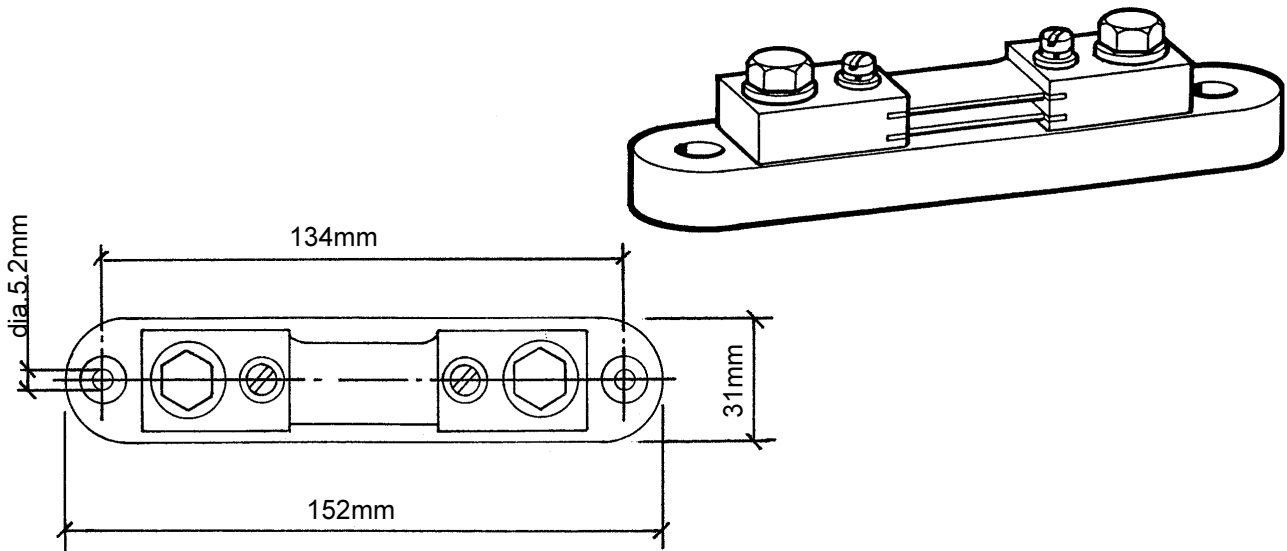

Part No.: X10-191-000-001

Wiring Kit (this is not part of the supply)

must consist of:

- 1x cable, black, 1 mm², 10 m long
- 1x cable, blue, 1 mm², 10 m long
- 1x cable, brown, 0.75 mm², 1 m long
- 1x cable, grey-red, 0.75 mm², 1 m long
- 2x eyelet terminal for 16 mm²
- 2x eyelet terminal for 10 mm²
- 2x self-tapping screw, ISO 1481-ST 4.2 x 22-C-A4 (DIN 7971)

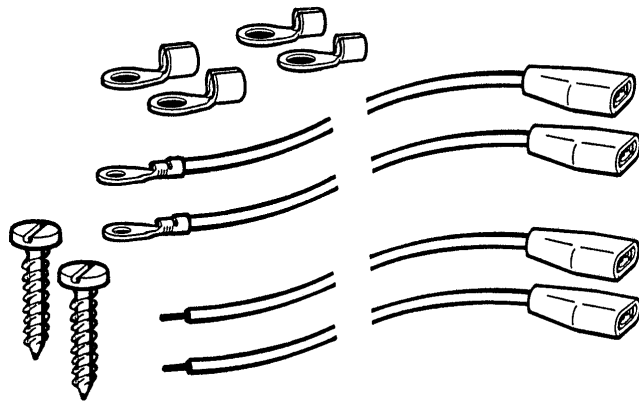

Do not shorten the black and the blue cable (10 m measuring leads).

Technical Product Manual

VDO cockpit vision VDO cockpit international

11. Ammeter (dia. 52 mm)

11.3 Wiring Diagram

Type A: basic wiring diagram

The instrument is connected to the circuit to have the charging current and the load of all consumers, except the starter motor, flowing through the ammeter.

The newly installed cable should have the same section as the available one, but at least:

- 6 mm² for measuring range ± 30 Ampere
- 16 mm² for measuring range ± 60 Ampere
- 35 mm² for measuring range ± 100 Ampere.

Connect the cable to the eyelet terminal.

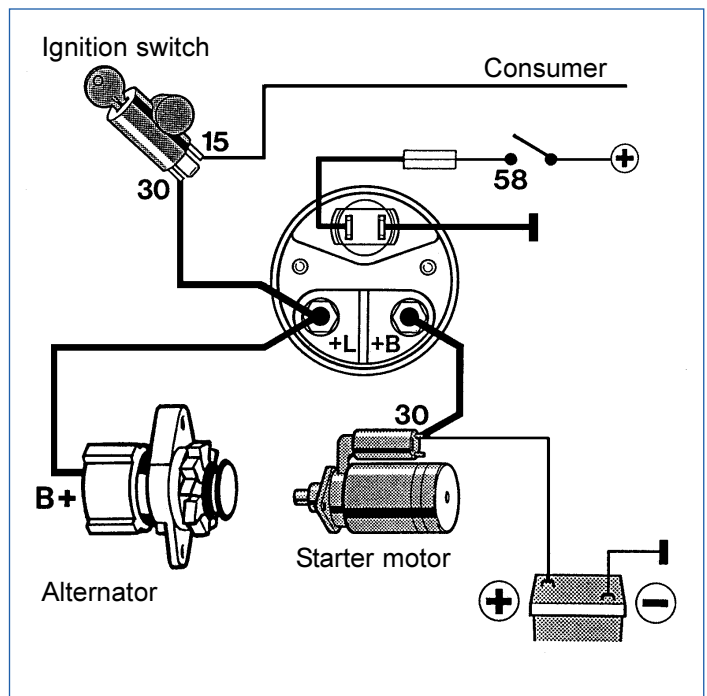
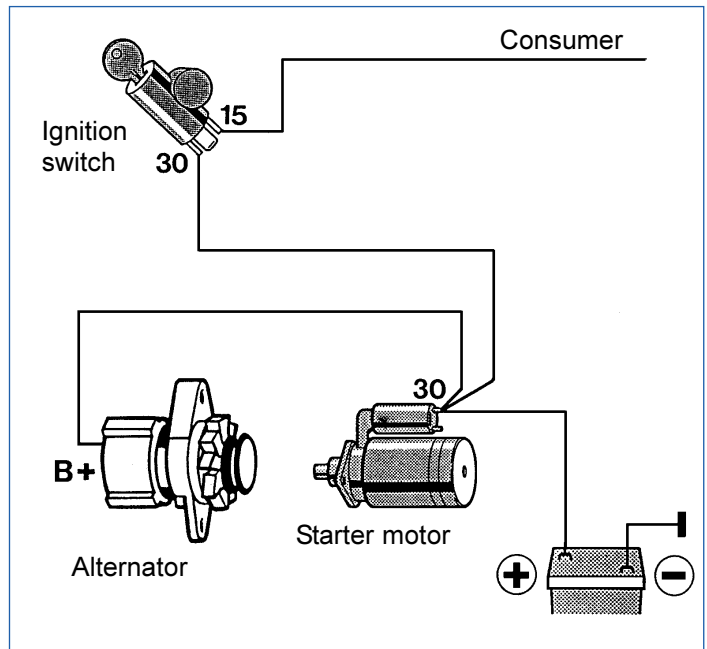

Technical Product Manual

VDO cockpit vision VDO cockpit international

11. Ammeter (dia. 52 mm)

11.3 Wiring Diagram

Type B (150 Ampere): Basic Wiring Diagram



Do not reduce the existing cable cross section.

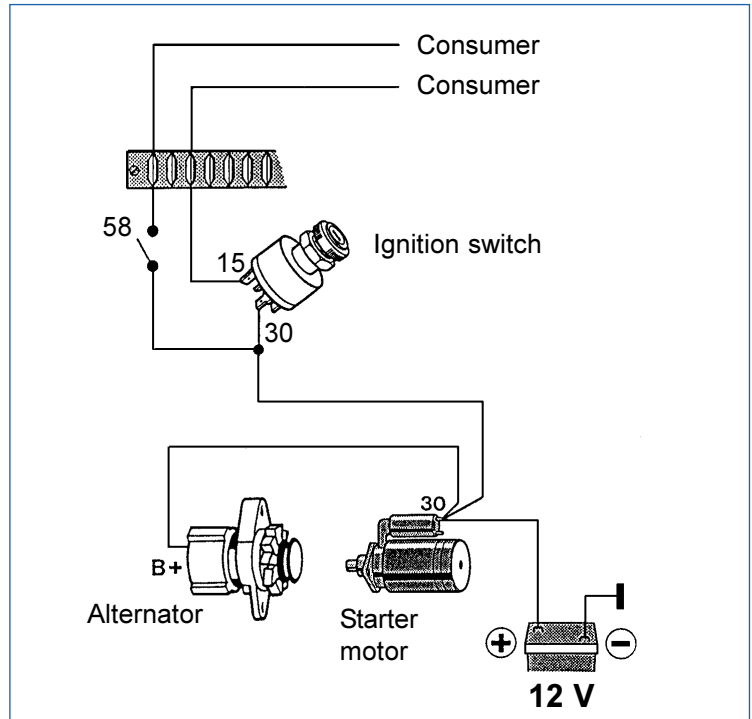

Wiring kit cables:

- a = blue, 1 mm², 10 m
- b = black, 1 mm², 10 m
- c = grey-red, 0.75 mm², 1 m
- d = brown, 0.75 mm², 1 m



Do not shorten the blue and the black cable (10 m measuring leads).

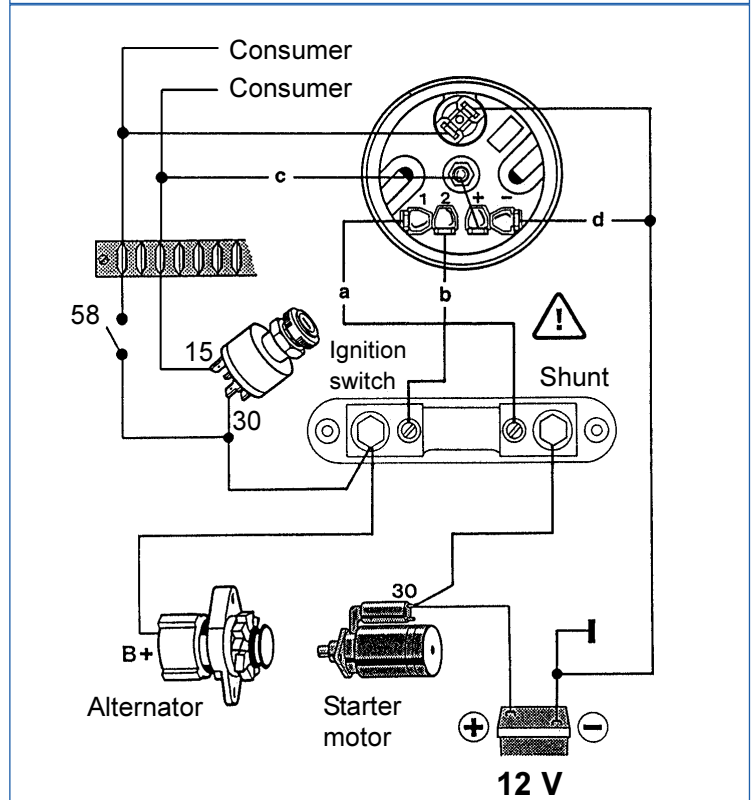

Technical Product Manual

VDO cockpit vision VDO cockpit international

11. Ammeter (dia. 52 mm)

11.4 Dropping Resistor for 24 V

Only for type B (150 Ampere)

The ammeter type B (nominal voltage 12 V) can also be used with a nominal voltage of 24 V if an external dropping resistor (option) is installed in the ground line (terminal – 31).

Connect this dropping resistor directly to pin – of the instrument, then connected it to the ground cable (d). In this case the operating voltage range is 21 V to 32 V.



Replace 12 V light bulb by 24 V light bulb.

Dropping resistor
Part No.: 800-005-027G

The dropping resistor is supplied with
24 V 2 W light bulb.

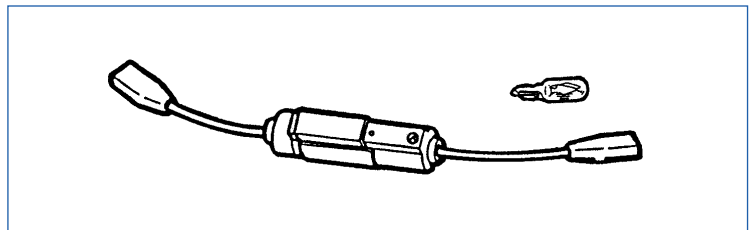

Do not reduce the existing cable cross section.

Wiring kit cables:
a = blue, 1 mm², 10 m
b = black, 1 mm², 10 m
c = grey-red, 0.75 mm², 1 m
d = brown, 0.75 mm², 1 m



Do not shorten the blue and the black cable (10 m measuring leads).

Basic wiring diagram

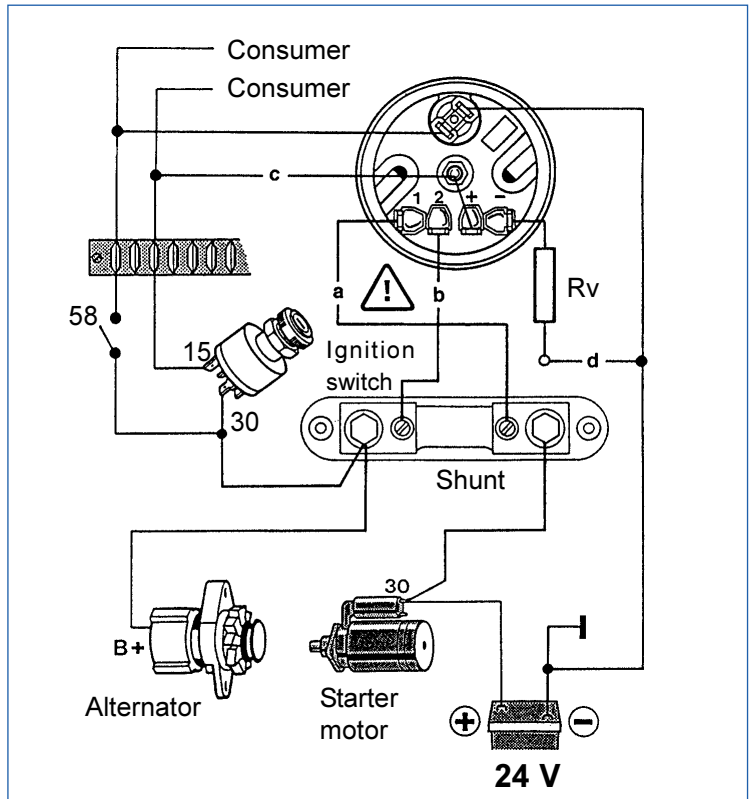

Rv = dropping resistor

Technical Product Manual

VDO cockpit vision VDO cockpit international

11. Ammeter (dia. 52 mm)

11.5 Instruments Survey

VDO cockpit vision (Backlight) dia. 52 mm

Type A

Part No. 190-077-. . .

Dial		Special feature	Part No.
Range	Imprint		
- 30 ... + 30 Amp.	- AMP +	Metal housing 12 V	001K
- 60 ... + 60 Amp.	- AMP +	Metal housing 12 V	002K

VDO cockpit international (Floodlight) dia. 52 mm

Type A

Part No. 190-037-. . .

Dial		Special feature	Part No.
Range	Imprint		
- 30 ... + 30 Amp.	- AMP +	Metal housing 12 V	001C 001G
- 60 ... + 60 Amp.	- AMP +	Metal housing 12 V	002C 002G
- 100 ... + 100 Amp.	- AMP +	Metal housing 12 V	003C 003G

VDO cockpit international (Floodlight) dia. 52 mm

Type B

Part No. 190-035-. . .

Dial		Special feature	Part No.
Range	Imprint		
- 150 ... + 150 Amp.	AMP - 15 ... + 15 x10	Plastic housing, clamp ring 12 V	005C

Technical Product Manual

VDO cockpit vision VDO cockpit international

12. Electric Clock (dia. 52 mm)

Contents	Page
12.1 General information	12 - 2
12.2 Technical data	12 - 3
12.3 Wiring diagram	12 - 6
12.4 Setting	12 - 7
12.5 Instruments survey	12 - 8

Installation instructions (old generation)

999-161-021: VDO cockpit vision
999-161-022: VDO cockpit international

See file 'Installation Instructions (MA)'.

Technical Product Manual

VDO cockpit vision VDO cockpit international

12. Electric Clock (dia. 52 mm)

12.1 General Informations

The electric clock has been designed for land-bound vehicles or stationary systems only (with the exception of motorcycles).

The instrument has an analog display (hours and minutes hands).

Designation of function (Quartz crystal movement)

The electronic circuit with quartz, stepping motor and reduction gears is the main component of the quartz clock.

A circuit board carries the quartz, the integrated circuit and the other electronic components.

The time is determined in an electronic circuit by high-frequency oscillation of a quartz crystal. This sustained oscillation (4.19 MHz) is obtained by application of an alternating voltage, and stabilizes the oscillator circuit. The high oscillating frequency thus stabilized by the quartz crystal is adjusted, and is stepped down to the 0.5 Hz frequency needed for the stepping motor.

The stepping motor has a rotor driven by current pulses of alternating polarity. The rotor steps are transmitted to the reduction gears, thereby driving the minutes and hours hands.

Illumination

- New generation:
The instrument is illuminated by a light bulb on the circuit board.
- Old generation:
The instrument is illuminated by a light bulb, which is plugged into a lamp socket.



The lamp socket is clipped in.
To replace the lamp bulb, carefully, with the thumb, push the lamp holder out to the side.

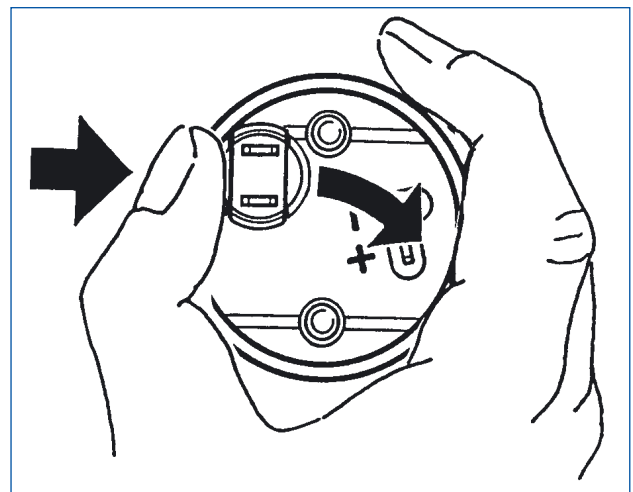

Technical Product Manual

VDO cockpit vision VDO cockpit international

12. Electric Clock (dia. 52 mm)

12.2 Technical Data

Operating voltage: 9V to 16V or 18V to 28V

Current consumption at 13,5V: < 10mA at room temperature

Current consumption at 26V: < 23mA at room temperature

Operating temperature: - 40°C to + 85°C

Storage temperature: - 40°C to + 90°C

Vibration resistance (acc. to IEC 60068 part 2-6):
2g, 25 Hz to 500 Hz, 24h x, y, z

Physical shock (acc. to IEC 60068 part 2-27):
100g, 6ms, 2times x, y, z

Accuracy: ± 5s per day at room temperature

Protection: IP40 DIN 40050 from the front

CE-approved, KBA-approval

Connections: blade terminals 6.3 x 0.8mm acc. to
DIN 46244 (reverse-polarity protection)

Illuminated (white)

New generation

VDO cockpit vision



VDO cockpit international

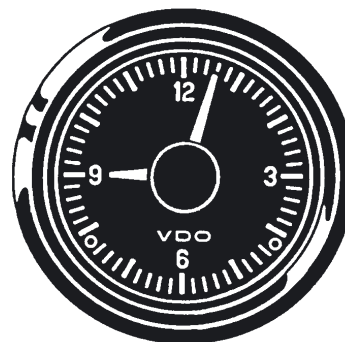

Mounting hole: dia. 53mm

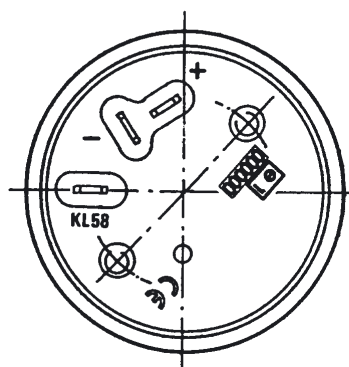

7.4 ± 0.2mm 51.7 ± 1mm

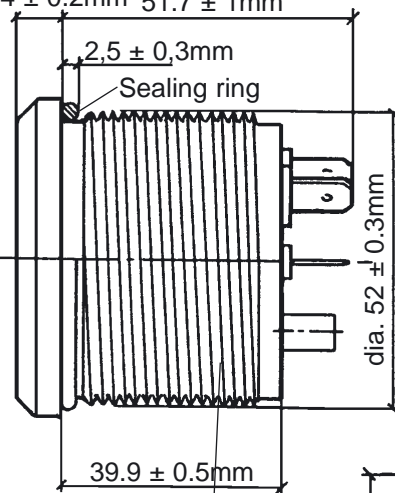

57.6 ± 0.2mm

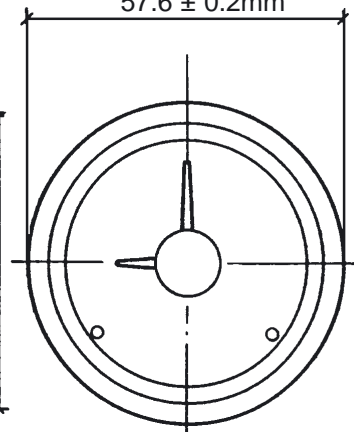

Pin assignment:

Pin +: + 12 V or + 24 V
(terminal 30)

Pin -: Ground, (term. 31)

Pin Kl. 58: Illumination, (term. 58)

Thread for clamp ring

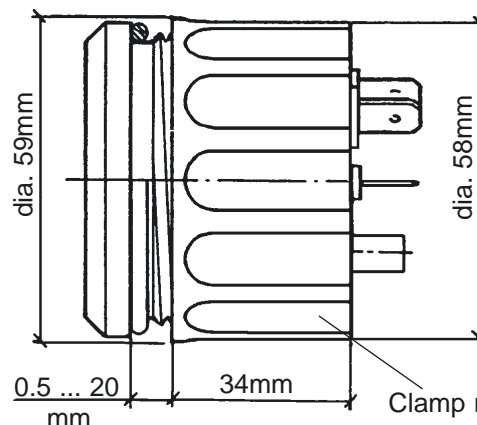

Clamping width 0.5 ... 20 mm

Clamp ring

Technical Product Manual

VDO cockpit vision VDO cockpit international

12. Electric Clock (dia. 52 mm)

12.2 Technical Data

Rated voltage:	12 V or 24 V
Current consumption:	< 3.1 mA (at 12 V)
Operating temperature:	- 40°C . . . + 80°C
Illumination:	1 light bulb 12 V, 2 W or 24 V, 2 W, 2 colour caps, green and red
Protection:	IP40 DIN 40050 from the front
Running precision:	< = 1 sec / 24 h at + 23°C ± 3 °C

Old generation

VDO cockpit vision

Backlight



Mounting hole: dia. 53mm

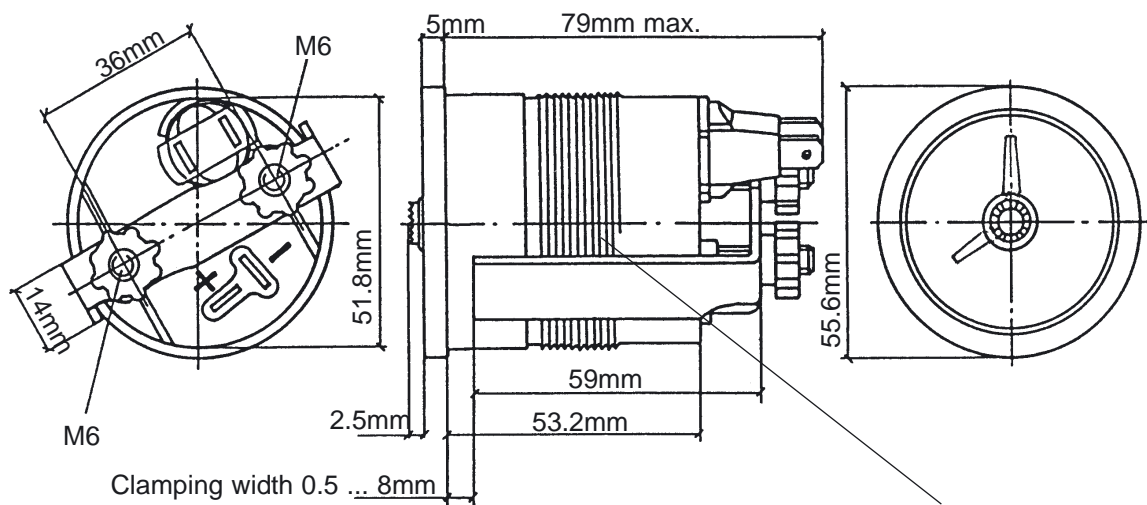

Clamping width 0.5 ... 8mm

Thread for clamp ring
(clamping width 0.5 ... 12mm
or 12 ... 23mm)

Pin assignment:

Pin +: + 12 V or + 24 V
terminal 30

Pin -: Ground, terminal 31

Technical Product Manual

VDO cockpit vision VDO cockpit international

12. Electric Clock (dia. 52 mm)

12.2 Technical Data

Rated voltage:	12 V or 24 V
Current consumption:	< 3.1 mA (at 12 V)
Operating temperature:	- 40°C ... + 80°C
Illumination:	1 light bulb 12 V, 2 W or 24 V, 2 W
Protection:	IP40 DIN 40050 from the front
Running precision:	< = 1 sec / 24 h at + 23°C ± 3 °C

Old generation

VDO cockpit international

Floodlight



Mounting hole: dia. 53mm

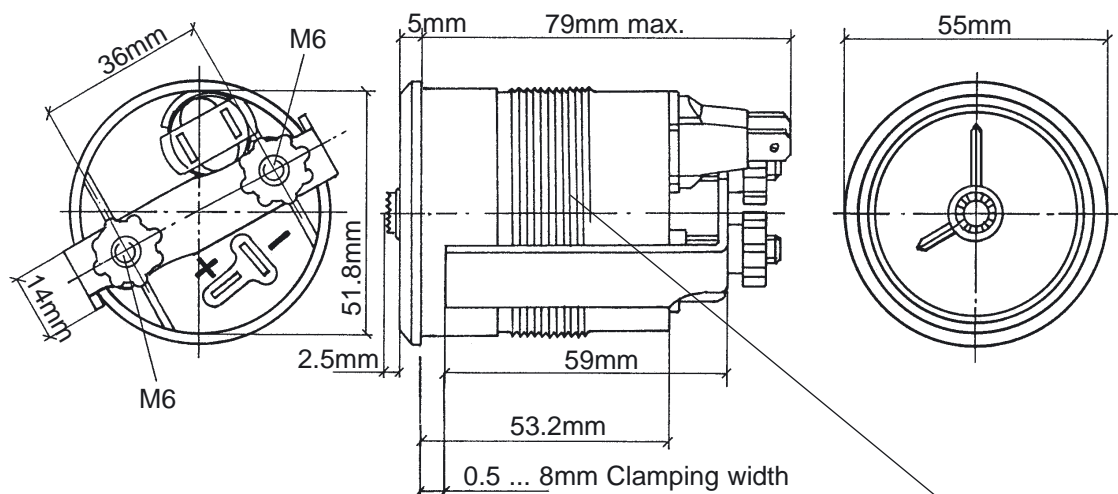

Thread for clamp ring
(clamping width 0.5 ... 12mm
or 12 ... 23mm)

Pin assignment:

Pin +: + 12 V or + 24 V
terminal 30

Pin -: Ground, terminal 31

Technical Product Manual

VDO cockpit vision VDO cockpit international

12. Electric Clock (dia. 52 mm)

12.3 Wiring Diagram

New generation

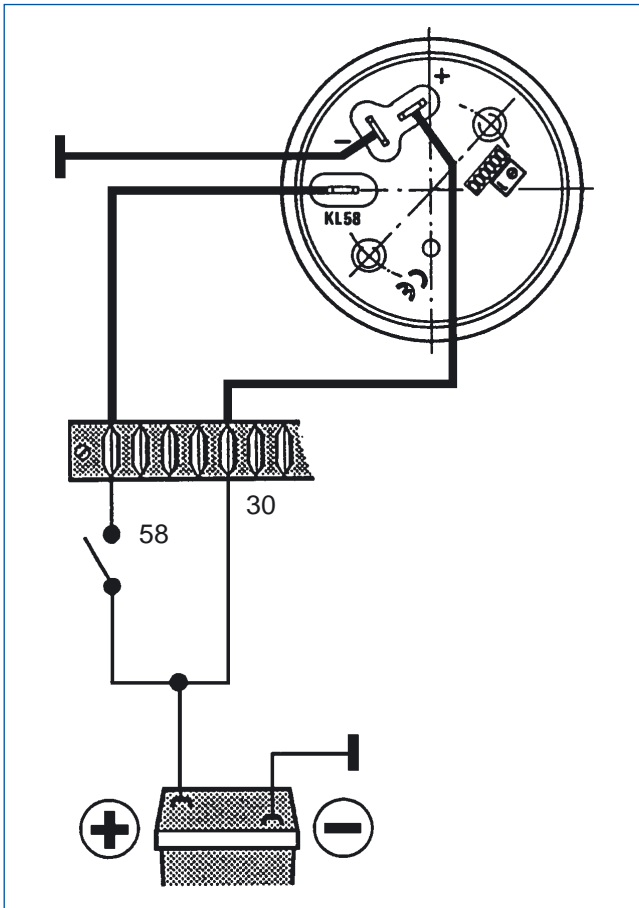

Old generation

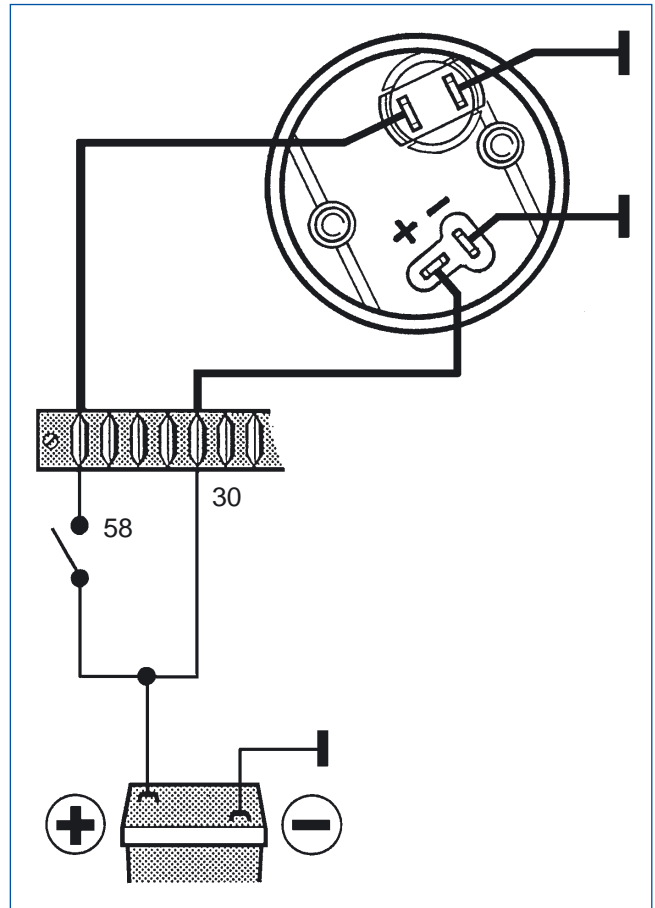

Technical Product Manual

VDO cockpit vision VDO cockpit international

12. Electric Clock (dia. 52 mm)

12.4 Setting

New generation:

The clock can be set by pressing two buttons: the left button moves the pointer counterclockwise, the right button moves the pointer clockwise.

The pointer moves in minutes by shortly pressing one button. If the button is being pressed longer than one second the pointer moves in minutes for 5 seconds and then continues at a higher speed.

If the pointer has moved 360 angular degrees, it stops shortly and then moves at higher speed. This function is useful when setting summer and winter time.

Setting is finished as soon as the button is released.

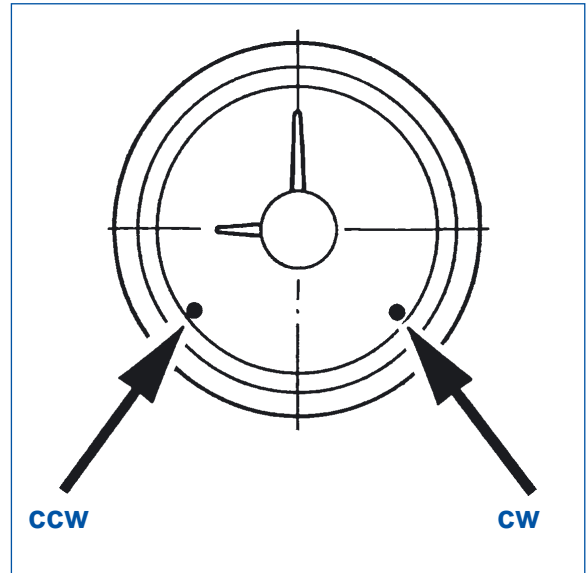

Old generation:

The electric clock is set with a rotating button in the lens center.

Push the button and turn (any direction).

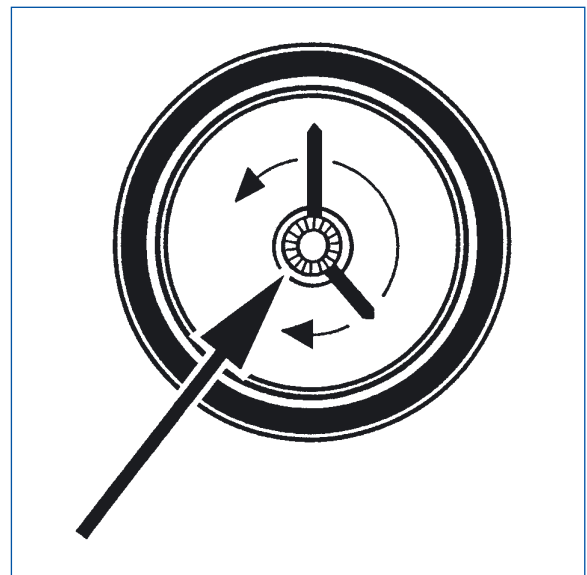

Technical Product Manual

VDO cockpit vision VDO cockpit international

12. Electric Clock (dia. 52 mm)

12.5 Instruments Survey

– New generation:

VDO cockpit vision

Dial	Special feature	Part No.
Imprint		
3, 6, 9, 12 VDO	12 V white illumination	370-214-031-002K
3, 6, 9, 12 VDO	24 V white illumination	370-214-031-004K

VDO cockpit international

Dial	Special feature	Part No.
Imprint		
3, 6, 9, 12 VDO	12 V	370-214-031-001G
3, 6, 9, 12 VDO	24 V	370-214-031-003G

– Old generation (phaseout):

VDO cockpit vision (Durchlicht)

Dial	Special feature	Part No.
Imprint		
3, 6, 9, 12 VDO	12 V	370-012-001K
3, 6, 9, 12 VDO	24 V	370-022-001C

VDO cockpit international (Auflicht)

Dial	Special feature	Part No.	
Imprint			
3, 6, 9, 12 VDO	12 V	370-032-001G	
Ground: white Imprint black	3, 6, 9, 12 VDO	12 V red illumination	370-032-003G
3, 6, 9, 12 VDO	24 V	370-032-004G	

Technical Product Manual

VDO cockpit vision VDO cockpit international

13. Electronic Operating Hours Counter (dia. 52 mm)

(only for VDO cockpit international)

Contents

Page

13.1 General informations	13 - 2
13.2 Technical data	13 - 4
13.3 Wiring diagram	13 - 6
13.4 Instruments survey	13 - 7

Installation instructions (old generation)

999-161-023: VDO cockpit international

See file 'Installation Instructions (MA)'.

Technical Product Manual

VDO cockpit vision VDO cockpit international

13. Electronic Operating Hours Counter (dia. 52 mm)

(only for VDO cockpit international)

13.1 General Informations

The electronic operating hours counter has been designed for land-bound vehicles or stationary systems only (with the exception of motorcycles).

The instrument displays the operating hours by number wheels, up to a maximum of 99999.9 hours.

A red indication wheel in the dial center or a red indication wheel with pointer indicates that the operating hours counter is counting by turning in clockwise direction.

The counter indication cannot be changed.

New generation (exploded assembly drawing)

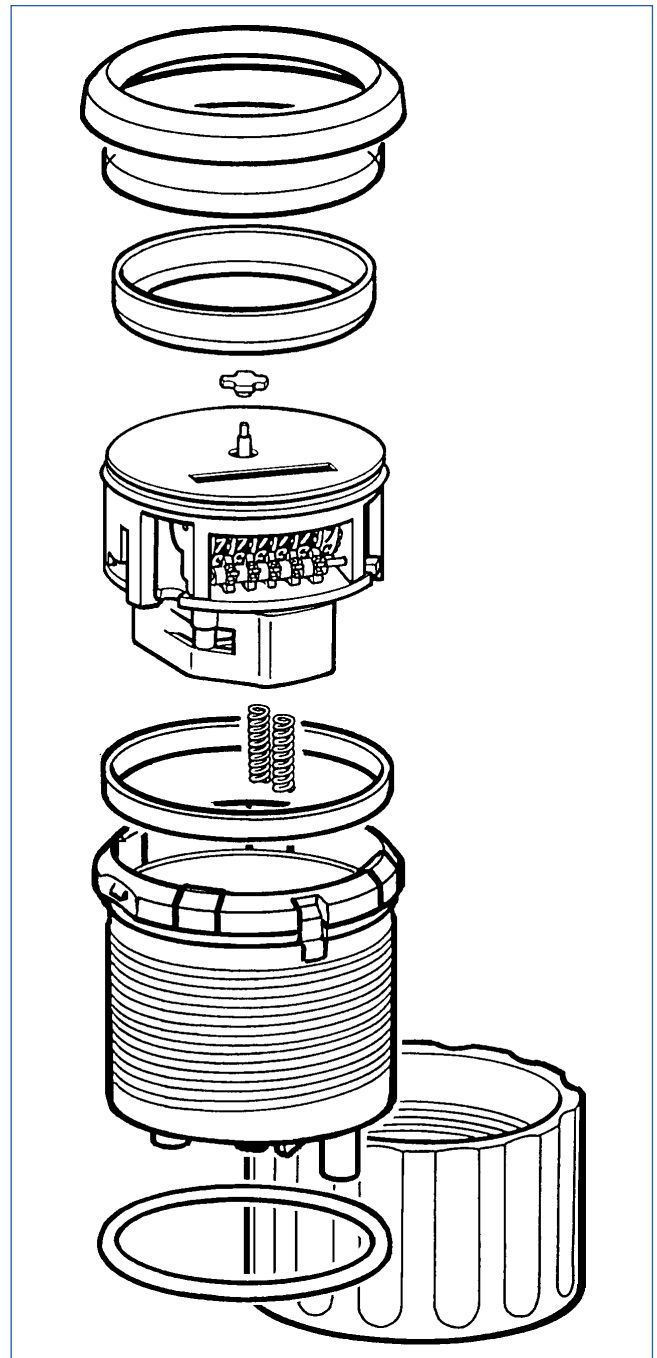

Technical Product Manual

VDO cockpit vision VDO cockpit international

13. Electronic Operating Hours Counter (dia. 52 mm)

(only for VDO cockpit international)

13.1 General Informations

Designation of function

Movement: quartz controlled movement with number-wheel type counter

The electronic operating hours counter is driven by a frequency-dependent stepping motor. The pulses needed for motor control are generated by a quartz-stabilized oscillator circuit, and processed by electronic circuitry. The oscillator is connected to a quartz in a feed-back loop. The alternating voltage of the oscillator causes mechanical oscillation of the quartz, which generates a frequency to control the oscillation circuit. The oscillating frequency is necessary for the pulsing of the stepping motor.

The stepping motor rotation is transmitted to the number-wheel type counter and the operation indicator by a mechanical system.

The counter sums and displays the operating hours, the operation indicator displays the operation of the instrument in one-second steps. A indication wheel in the dial center indicates that the operating hours counter is counting by turning in clockwise direction.

New generation

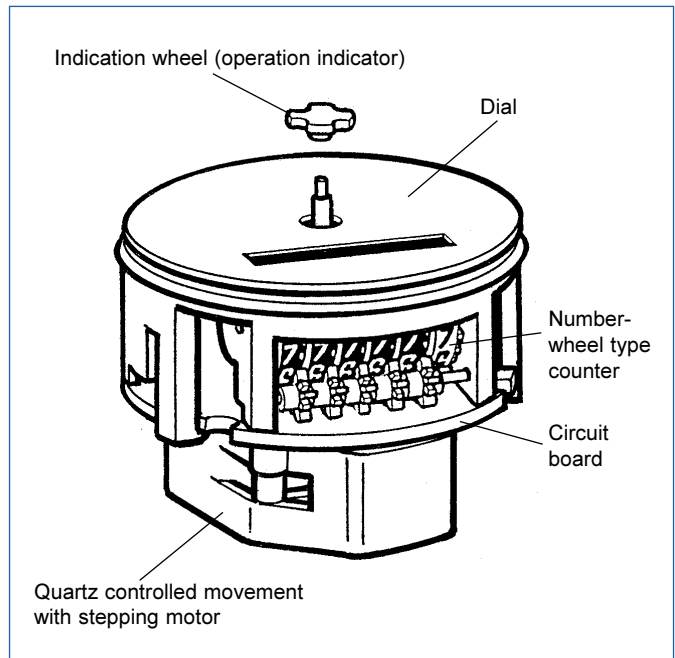

Old generation

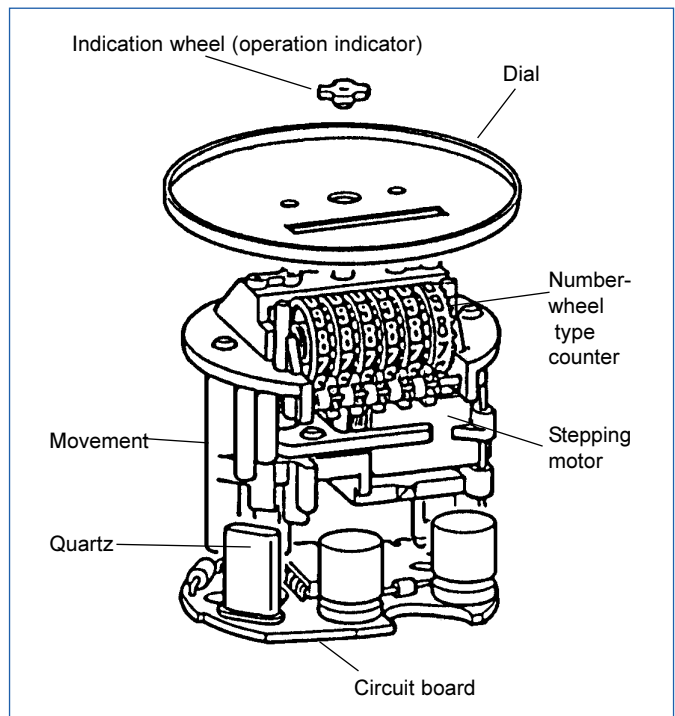

Technical Product Manual

VDO cockpit vision VDO cockpit international

13. Electronic Operating Hours Counter (dia. 52 mm)

(only for VDO cockpit international)

13.2 Technical Data

New generation

VDO cockpit international

Operating voltage:	9V to 28V or 9V to 16V or 18V to 28V
Movement:	quartz controlled movement with number-wheel type counter
Current consumption at room temperature:	at 13.5 V: < 10 mA at 26 V: < 23 mA
Operating temperature:	- 40°C to + 85°C
Storage temperature:	- 40°C to + 90°C
Protection:	IP65 DIN 40 050 front side IP42 DIN 40 050 rear side (or IP65)
CE approved, KBA registration	
Vibration resistance (according to IEC 68 part 2-6):	2g, 25 Hz to 500 Hz, 24h x, y, z
Physical shock (according IEC 68 part 2-27):	100 g, 6 ms, 2 mal x, y, z
Operating hours counting:	99999,9 h max. (nonresettable)
Indication accuracy:	
at room temperature:	± 5s per day
-40°C to +85°C:	max. -10s per day
Illuminated or no illumination	



(Illustration without illumination)

Mounting hole: dia. 53mm

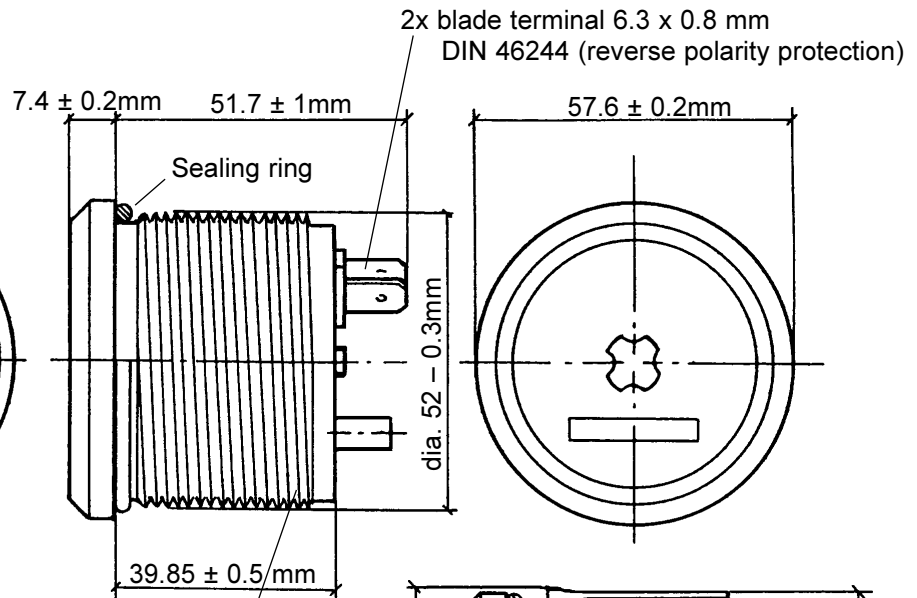
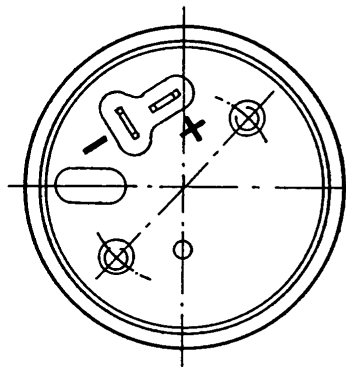

2x blade terminal 6.3 x 0.8 mm
DIN 46244 (reverse polarity protection)

Pin assignment:

- Pin +: Alternator, terminal D+
- Pin -: Ground, terminal 31
- Pin KL 58: Illumination
(only by gauges with illumination)

Thread for clamp ring

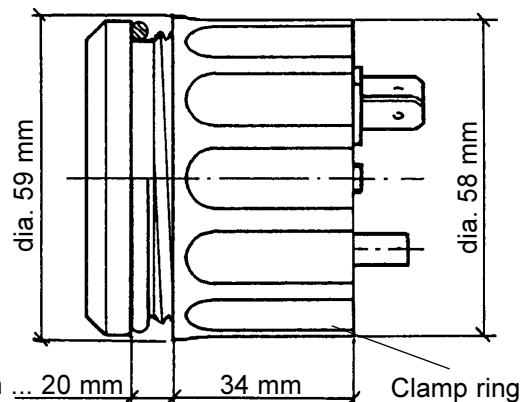

Technical Product Manual

VDO cockpit vision VDO cockpit international

13. Electronic Operating Hours Counter (dia. 52 mm)

(only for VDO cockpit international)

13.2 Technical Data

Operating voltage:	12 V to 24 V
Movement:	quartz controlled movement with number-wheel type counter
Current consumption:	at 12 V: < 5 mA at 24 V: < 15 mA
No illumination	
Operating temperature:	- 40°C to + 85°C
Storage temperature:	- 40°C to + 90°C
Protection:	IP64 DIN 40050 from the front
Vibration resistance:	max. 1g eff., 25 to 500 Hz duration 8 h, f: 1 octave/min.
Operating hours counting:	max. 99999.9 h (nonresettable)

Old generation

VDO cockpit international

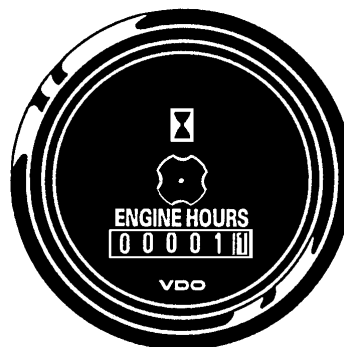

Mounting hole: dia. 53mm

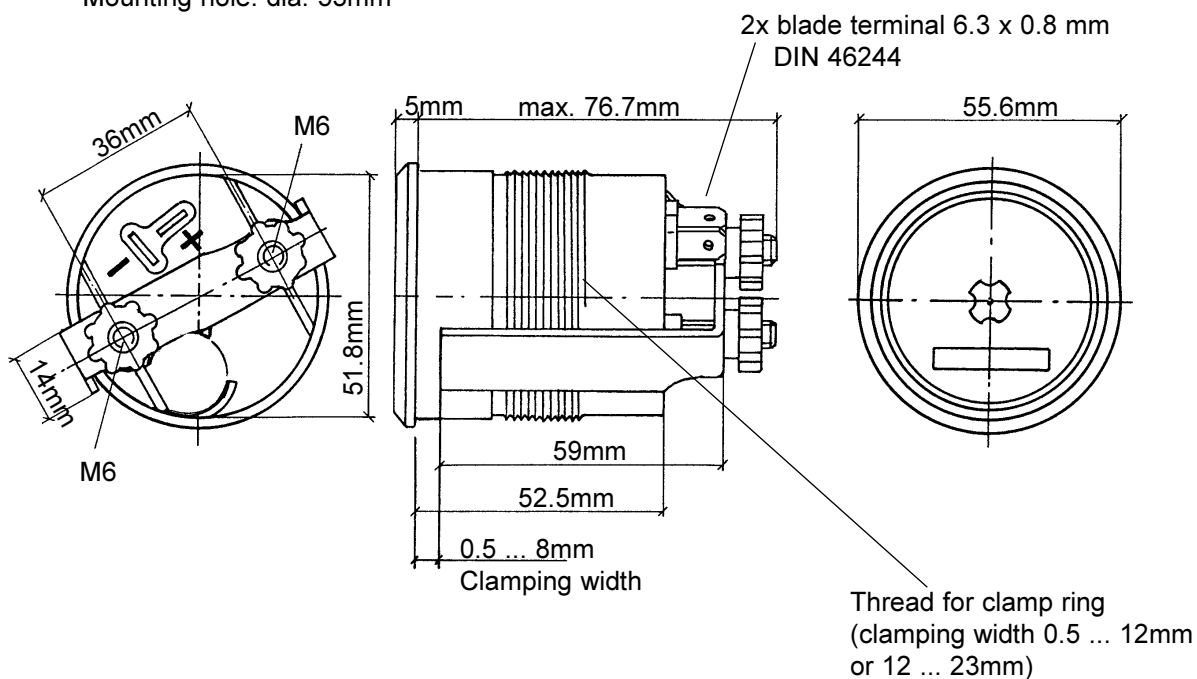

Pin assignment:

Pin +: Alternator,
terminal D+

Pin -: Ground, terminal 31

Technical Product Manual

VDO cockpit vision VDO cockpit international

13. Electronic Operating Hours Counter (dia. 52 mm)

(only for VDO cockpit international)

13.3 Wiring Diagram

New generation:

No illumination

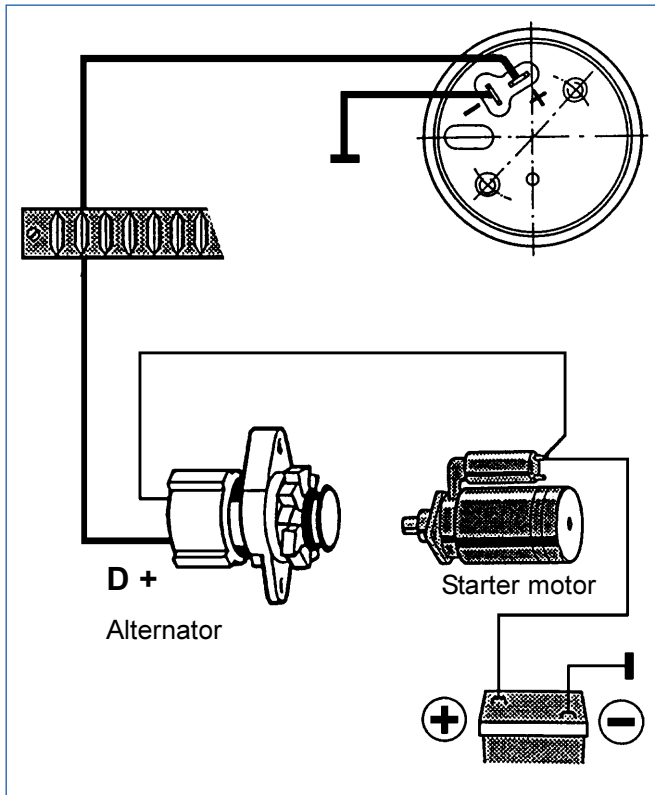

With illumination

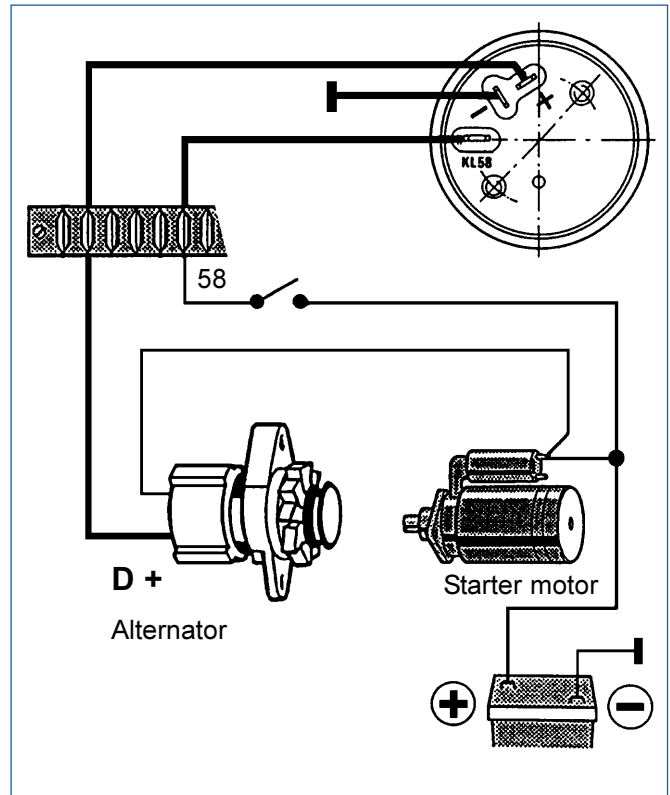

Old generation

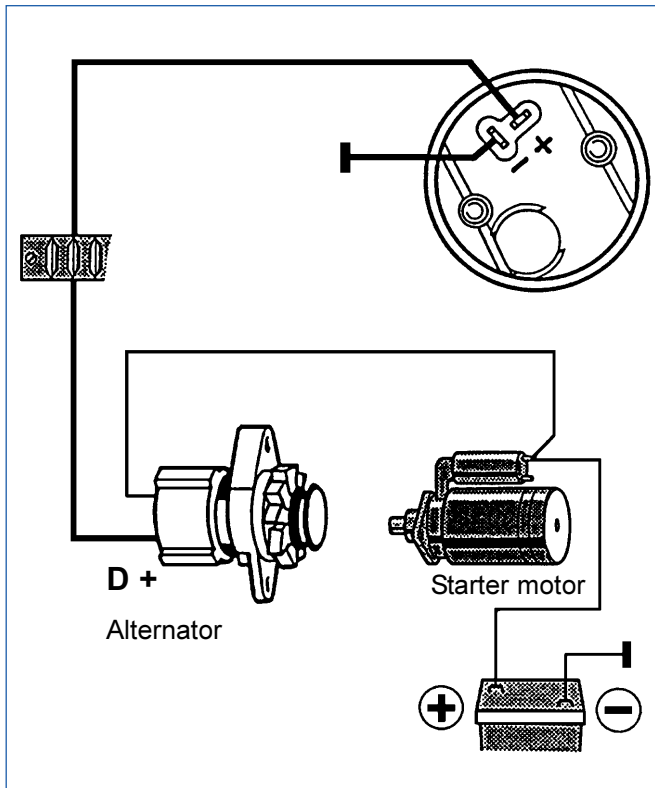

Technical Product Manual

VDO cockpit vision VDO cockpit international







13. Electronic Operating Hours Counter (dia. 52 mm)

(only for VDO cockpit international)

13.4 Instruments Survey

— New generation :





VDO cockpit international

Dial		Version	Part No.
Measuring range	Imprint		
99999.9 h.	 HOURS VDO	9V - 28V no illumination	331-810-012-001B 331-810-012-001G
99999.9 h.	 HOURS VDO (minutes scale)	9V - 28V, minutes hand (wt) no illumination	331-810-012-002B 331-810-012-002G
99999.9 h.	 HOURS VDO	9V - 28V, no illumination bezel chrome plated	331-810-012-003B
99999.9 h.	 HOURS VDO	9V - 16V, with illumination (wt) USA (specific version)	331-810-012-004B
99999.9 h.	 HOURS VDO	18V - 28V, with ill. (wt), bezel chrome pl., USA (specific version)	331-810-012-005
99999.9 h.	individual Customer-version	9V - 28V, no ill., water-p. (IP 65), USA (specific version)	331-810-012-006B
99999.9 h.	 HOURS VDO	18V - 28V, with illumination (wt), USA (specific version)	331-810-012-007B
99999.9 h.	individual Customer-version	9V - 28V, no ill., water-p. (IP 65), bezel chrome pl., USA (specific version)	331-810-012-008
99999.9 h.	 HOURS VDO	9V - 16V, with illumination (wt), bezel chrome pl., USA (specific version)	331-810-012-009
99999.9 h.	individual Customer-version	9V - 28V, no illumination, bezel chrome plated	331-810-012-010B

— Old generation (phaseout):

VDO cockpit international

Part No. 331-032-...

Dial		Version	Part No.
Measuring range	Imprint		
99999.9 h	 ENGINE HOURS VDO	12 - 24V no illumination	001C 001G
99999.9 h	 ENGINE HOURS VDO	12 - 24V, bezel chrome plated no illumination	003C
99999.9 h	 ENGINE HOURS VDO (minutes scale)	12 - 24V, minute hand no illumination	004C 004G
99999.9 h	 ENGINE HOURS VDO	8 - 24V, < 4 mA at 12V no illumination	007C
99999.9 h	 ENGINE HOURS VDO	8 - 24V, < 4 mA at 12V helical gear ring, no illumination	008C

Technical Product Manual

VDO cockpit vision VDO cockpit international

14. Temperature Measuring System For Exterior Temperature (dia. 52 mm)

Contents	Page
14.1 General informations	14 -2
14.2 Technical data	14 -3
14.3 Temperature sensor	14 -5
14.4 Wiring diagram	14 -6
14.5 Dropping resistor for 24 V	14 -7
14.6 Testing instructions	14 -8
14.7 Systems survey	14 -10

Installation instructions

999-165-007: VDO cockpit vision
999-165-016: VDO cockpit international

See file 'Installation Instructions (MA)'.

Technical Product Manual

VDO cockpit vision VDO cockpit international

14. Temperature Measuring System For Exterior Temperature (dia. 52 mm)

14.1 General Informations

The electronic temperature measuring system for exterior temperature has been designed for land-bound vehicles only (with the exception of motorcycles).

The instrument has an analog exterior temperature display in °C (– 25°C to + 40°C).

The sensor is a temperature sensor adapted to the measuring range of the indicating instrument (type: negative earth) with mounting and connection parts.

The lamp socket is pushed in.

To replace the lamp bulb simply pull the lamp holder out.

Designation of function

Movement: system Ke (to 320°)

(Turning magnet ratio measuring movement, pointer deflection up to 320°)

The ambient temperature affects a resistor-type sensor with negative temperature coefficient fixed outside of the vehicle, or in the passenger compartment. The temperature-dependent sensor resistance determines the measuring current of the electronic thermometer. Depending on the application, this will be a turning magnet ratio measuring movement with pointer deflection up to 320° (designation of function see tachometer, dia. 52mm), the pointer displaying a temperature value on the graduated dial.

In the important range between +10°C and –10°C the graduation has been spread by electronic means to obtain a higher resolution.

Technical Product Manual

VDO cockpit vision VDO cockpit international

14. Temperature Measuring System For Exterior Temperature (dia. 52 mm)

14.2 Technical Data

Temperature gauge, electronic

(Instrument separate not available. Only as set.)

Operating voltage:	10.8 ... 16 V
Movement:	System Ke (→ 320°C)
Current consumption:	< 100 mA (without illumination)
Operating temperature:	-20°C ... +70°C
Storage temperature:	-30°C ... +85°C
Illumination:	1 light bulb, 12 V, 1.2 W 2 colour caps (green and red)
Protection:	IP64 DIN 40050 from the front
Connections:	reverse-polarity protection
Vibration resistance:	max. 1g eff., 25 ... 500 Hz, duration 8 h, f: 1 octave/min.
Nominal position:	NL 0 to NL 90, DIN 16257

VDO cockpit vision
dia. 52 mm Backlight

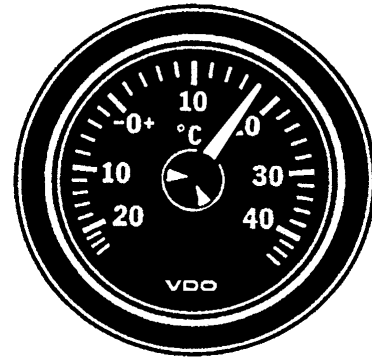

Mounting hole: dia. 53mm

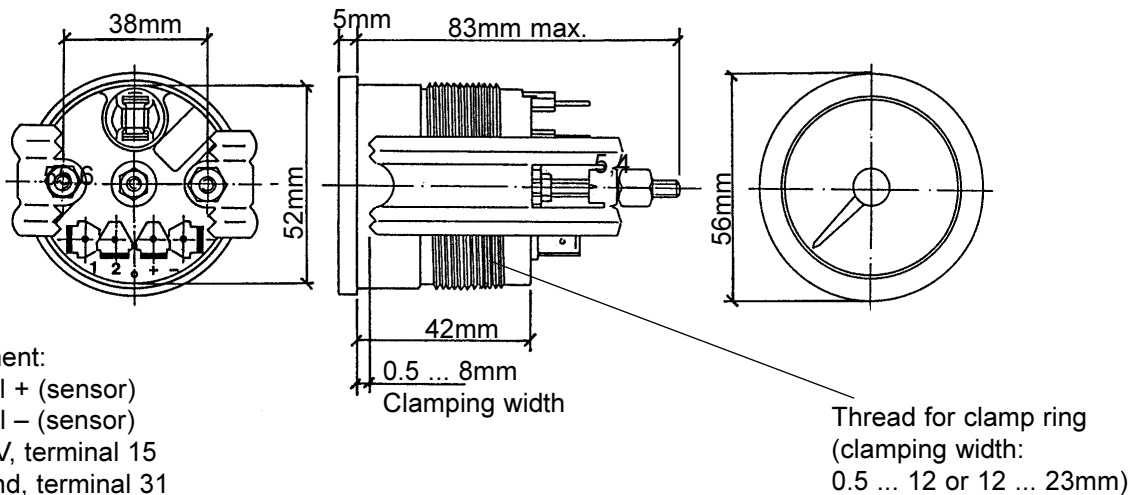

Temperature sensor (thermistor)

Negative earth

Rated voltage:	6 ... 24 V
Operating temperature:	-25 °C ... +120 °C
Tightening torque:	10 Nm (M10 x 1) 1 Nm (M4)

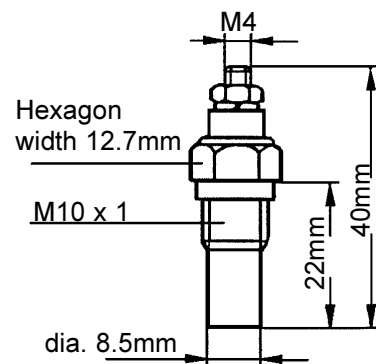

Bracket (brass)

matt nickel-plated

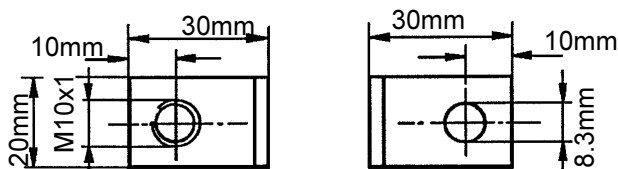

Supplied loose:
wire, connecting hardware and protective cap

Technical Product Manual

VDO cockpit vision VDO cockpit international

14. Temperature Measuring System For Exterior Temperature (dia. 52 mm)

14.2 Technical Data

Temperature gauge, electronic

(Instrument separate not available. Only as set.)

Operating voltage:	10.8 ... 16 V
Movement:	System Ke (→ 320°C)
Current consumption:	< 100 mA (without illumination)
Operating temperature:	- 20°C ... + 70°C
Storage temperature:	- 30°C ... + 85°C
Illumination:	1 light bulb 12 V, 2 W
Protection:	IP64 DIN 40050 from the front
Connections:	reverse-polarity protection
Vibration resistance:	max. 1g eff., 25 ... 500 Hz, duration 8 h, f: 1 octave/min.
Nominal position:	NL 0 to NL 90, DIN 16257

VDO cockpit international
dia. 52 mm Floodlight



Mounting hole: dia. 53mm

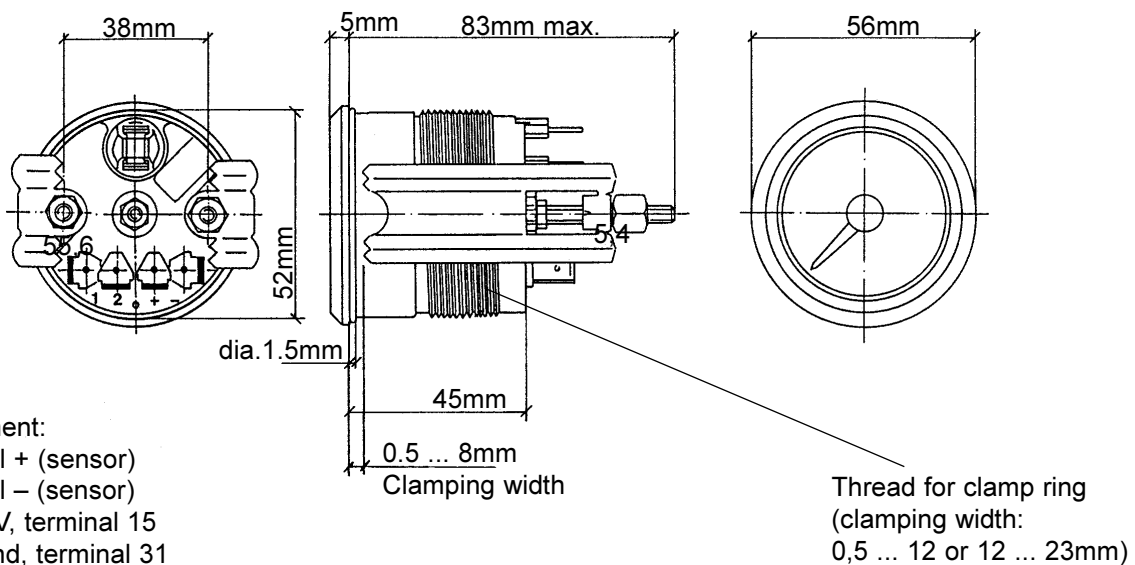

Pin assignment:

- Pin 1: Signal + (sensor)
- Pin 2: Signal - (sensor)
- Pin +: + 12 V, terminal 15
- Pin -: Ground, terminal 31

Temperature sensor (thermistor)

Negative earth

- Rated voltage: 6 - 24 V
- Operating temperature: - 25 °C ... + 120 °C
- Storage temperature: - 30 °C ... + 120 °C
- Tightening torque: 10 Nm (M10 x 1)
1 Nm (M4)

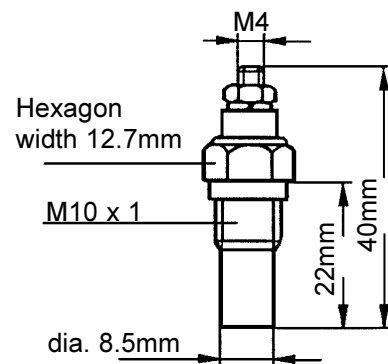

Bracket (brass)

matt nickel-plated

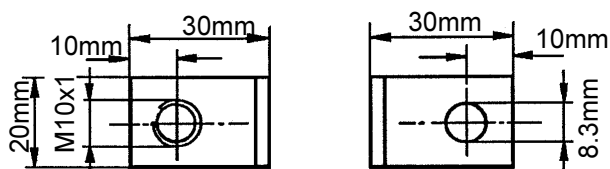

Supplied loose:
wire, connecting hardware and protective cap

Technical Product Manual

VDO cockpit vision VDO cockpit international

14. Temperature Measuring System For Exterior Temperature (dia. 52 mm)

14.3 Temperature Sensor

The temperature sensor needed to operate the electronic exterior temperature indicator is supplied with protecting cap, support bracket and connection parts .

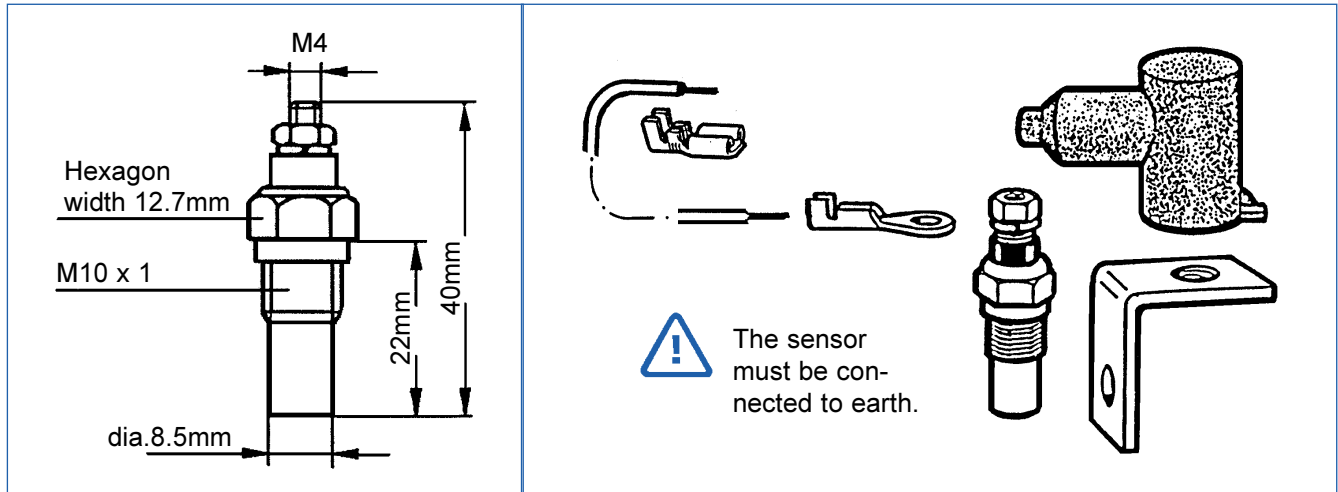

Temperature sensor, negative earth (part No. 323-801-008-002D)

Rated voltage:	6 V ... 24 V
Version:	Thermistor
Operating temperature:	- 25°C ... + 120°C short periods only for 10 minutes: +150°C max.
Tightening torque:	10 Nm (M10x1), 1 Nm (M4)
Operational value:	0°C = 1893 Ω ± 102 Ω

Location of sensor installation:

Mount the sensor on the passenger car front, behind the bumper or the body; on commercial vehicles install in the front area, with the body protecting against the wind, using the enclosed mounting bracket.

The sensor can be mounted in any direction. Select the location to avoid radiated heat (e. g. radiator, engine, exhaust system) which could lead to wrong indications.

Technical Product Manual

VDO cockpit vision VDO cockpit international

14. Temperature Measuring System For Exterior Temperature (dia. 52 mm)

14.4 Wiring Diagram

Connect the ground (pin -) of the indicating instrument to the ground point junction of the vehicle. A ground connection passing through another consumer (such as a cigarette lighter, a different indicating instrument, etc.) will cause wrong indications. Do not connect the instrument lighting ground to the indicating instrument ground.

Temperature sensor

negative earth

(part No.: 323-801-008-002D)
included

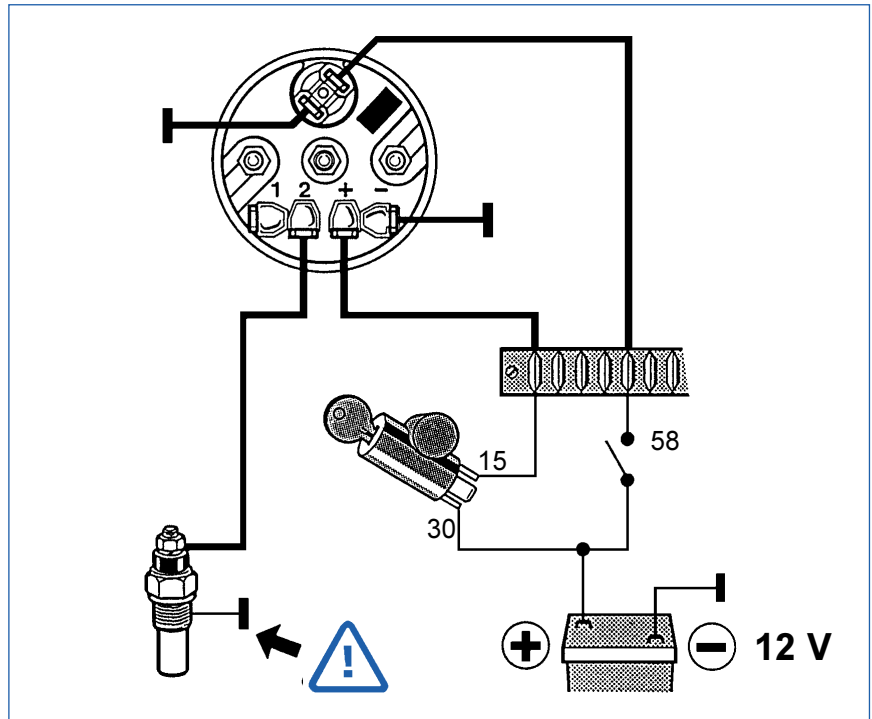

Technical Product Manual

VDO cockpit vision VDO cockpit international

14. Temperature Measuring System For Exterior Temperature (dia. 52 mm)

14.5 Dropping Resistor For 24 V

The electronic exterior temperature indicating instrument (rated voltage 12 V) can also be used with a rated voltage of 24 V if an external dropping resistor (option) is installed in the plus wire (terminal 15). In this case the operating voltage can be 21 V to 32 V.

 Replace 12 V light bulb by a 24 V light bulb..

VDO cockpit vision:

Dropping resistor with a 24 V 1.2 W light bulb.
Part No.: 800-005-011G

VDO cockpit international:

Dropping resistor with a 24 V 2 W light bulb.
Part No.: 800-005-027G

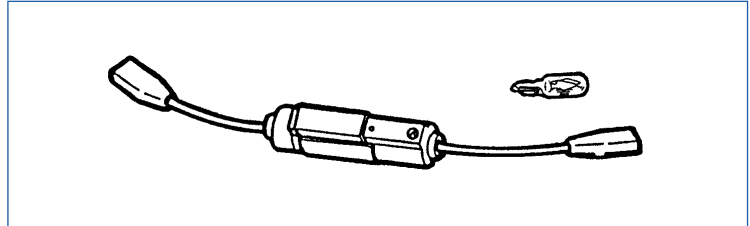

Wiring diagram

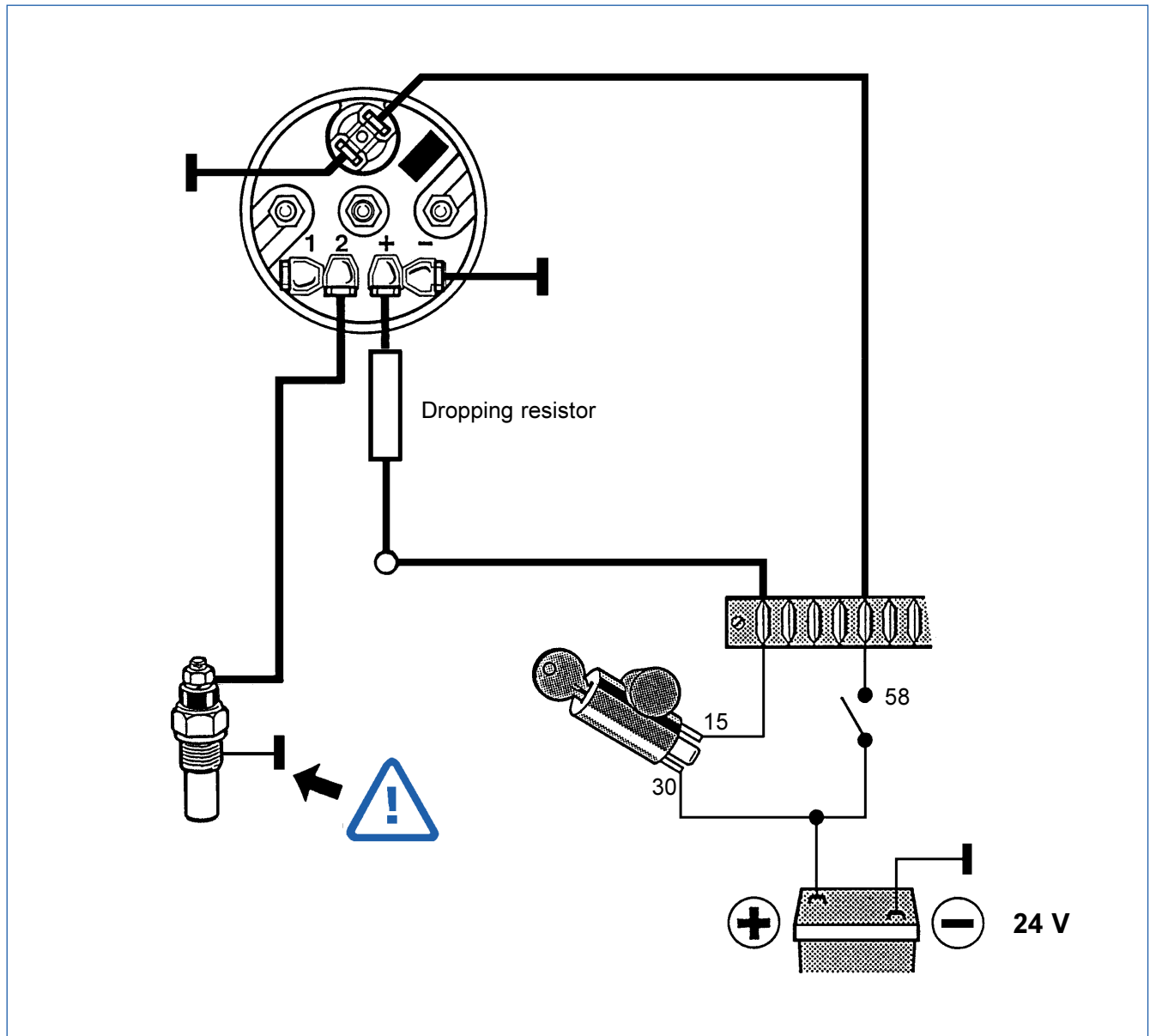

Technical Product Manual

VDO cockpit vision VDO cockpit international

14. Temperature Measuring System For Exterior Temperature (dia. 52 mm)

14.6 Testing Instructions

Indicating instrument

Test accessories: 1x power supply
1x test cable No. 3 } contained in test cables kit
1x measuring cable } X12-019-101-001
1x resistor decade
1x ammeter

Pin allocation:

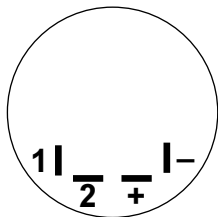

PIN + + 12V
PIN - Ground
PIN 2 Sensor signal input

Test circuit diagram:

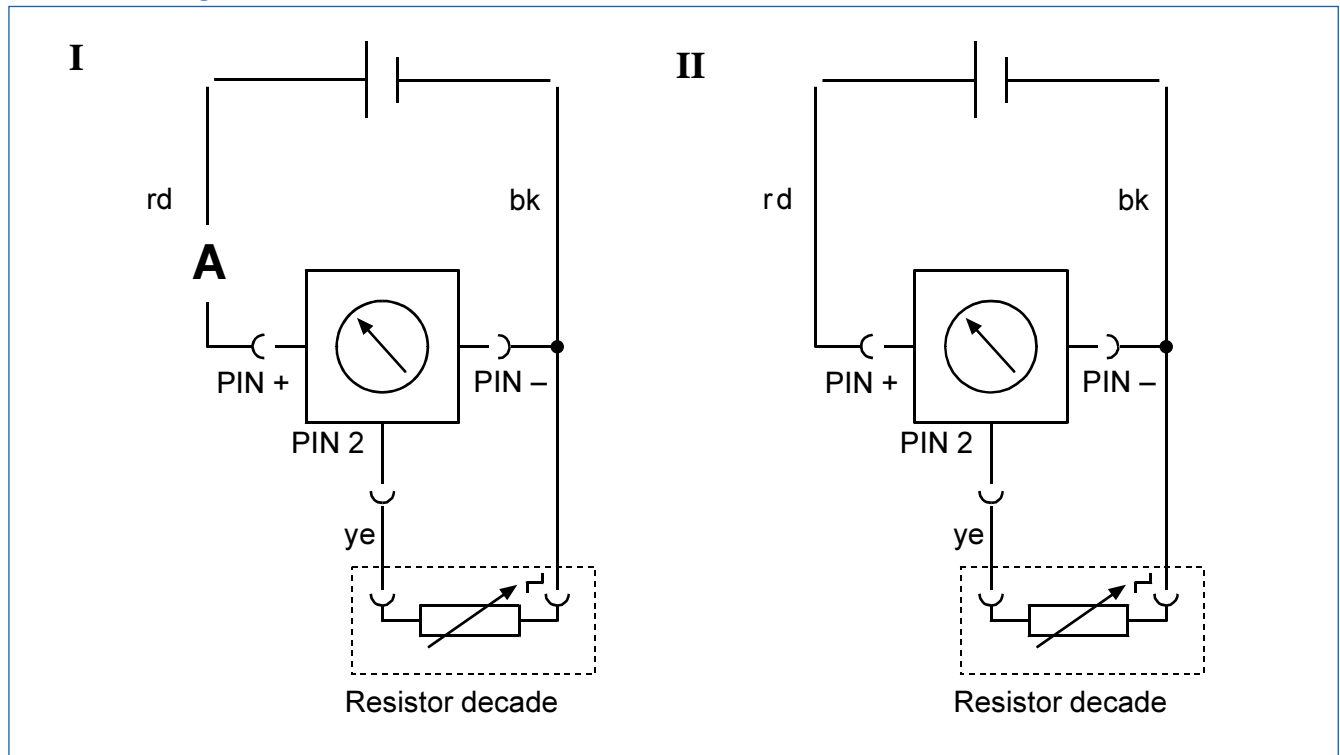

Test method description:

Basic settings: 12 V instruments \Rightarrow 14 V

*Measuring of the current consumption only with connected decade resistor box!
Start the pointer position test with the lowest resistance value!*

Technical Product Manual

VDO cockpit vision VDO cockpit international

14. Temperature Measuring System For Exterior Temperature (dia. 52 mm)

14.6 Testing Instructions

Indicating instrument

Measurement of current consumption

Connect instrument with test cable No. 3 as shown in test circuit diagram I.

Range of values: 12 V instrument  I = 70 ± 20 mA

Test of the movement

Connect the instrument according to the test circuit diagram II, using test cable 3.

The indication can be tested with the resistor decade 'sensor simulator'.

The following table shows the resistance values and the permissible indication tolerances in degrees Celcius:

Indication (°C)	-20	-10	0	10	20	30	40
Resistance (Ω)	5842	3271	1901	1148	715	460	303
Tolerance (°C)	±4	±4	±3	±2	±2	±2	±3

Technical Product Manual

VDO cockpit vision VDO cockpit international

14. Temperature Measuring System For Exterior Temperature (dia. 52 mm)

14.7 Systems Survey

VDO cockpit vision (Backlight) dia. 52 mm

Part No. 397-015-...

Dial		Special feature	Part No.
Range	Imprint		
- 25°C ... + 40 °C	°C	12 V	001K

VDO cockpit international (Floodlight) dia. 52 mm

Part No. 397-035-...

Dial		Special feature	Part No.
Range	Imprint		
- 25°C ... + 40 °C	°C	12 V	001C ● 001G

● Phase-out

Technical Product Manual

VDO cockpit vision VDO cockpit international

15. Mechanical Pressure Gauge (dia. 52 mm)

Contents	Page
15.1 General informations	15 - 2
15.2 Technical data	15 - 4
15.3 Instruments survey	15 - 6

Installation instructions

999-165-018: VDO cockpit vision
999-165-019: VDO cockpit international

See file 'Installation Instructions (MA)'.

Technical Product Manual

VDO cockpit vision VDO cockpit international

15. Mechanical Pressure Gauge (dia. 52 mm)

15.1 General Informations

The mechanical pressure gauge has been designed for land-bound vehicles or stationary systems only (exception: motorcycles).

The instrument has an analog pressure display for the measured medium.

Connecting parts for a commercial pressure hose (outer dia. 6mm, inner dia. 4mm) for charging pressure measurement, offering the corresponding pressure, temperature and measuring fluid or for a copper tubing (6mm dia. x 1mm) are included.



The lamp socket (not included by VDO cockpit international) is clipped in.
To replace the lamp bulb, carefully, with the thumb, push the lamp holder out to the side.

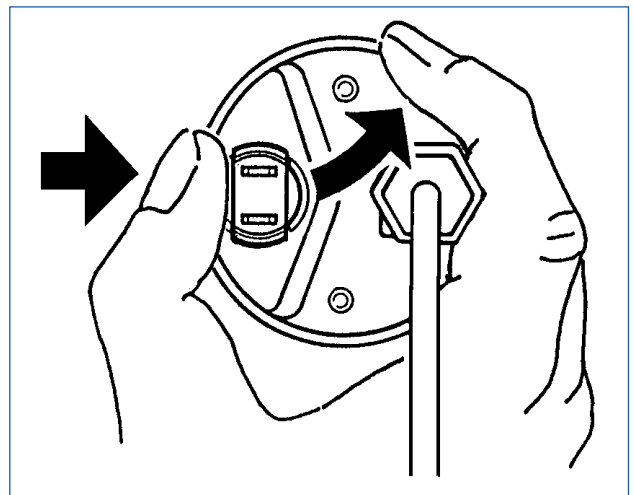

Technical Product Manual

VDO cockpit vision VDO cockpit international

15. Mechanical Pressure Gauge (dia. 52 mm)

15.1 General Informations

Designation of function

Movement: bourdon tube system

The pressure measuring principle applies the resilient deformation of a circular bourdon tube with nearly oval section, which is fixed at one side. The bourdon tube extends when a pressure is applied to its inside. The increase of the bending radius is a function of the pressure inside the tube. A gear system transfers the deflection, which is practically proportional to the pressure, to a pointer, which indicates the value of the pressure on a dial graduated values.

One end of the circular bourdon spring is soldered to the system body. A port connects the tube inside to the system body and the pressure connection. The free end of the bourdon tube carries a lever, which transfers the tube end deflection (proportional to the pressure) to a toothed sector engaged in a sprocket, which converts the deflection to a rotation and a pointer deflection. Backlash of gears and bearings in the transmission system is compensated by a spiral spring.

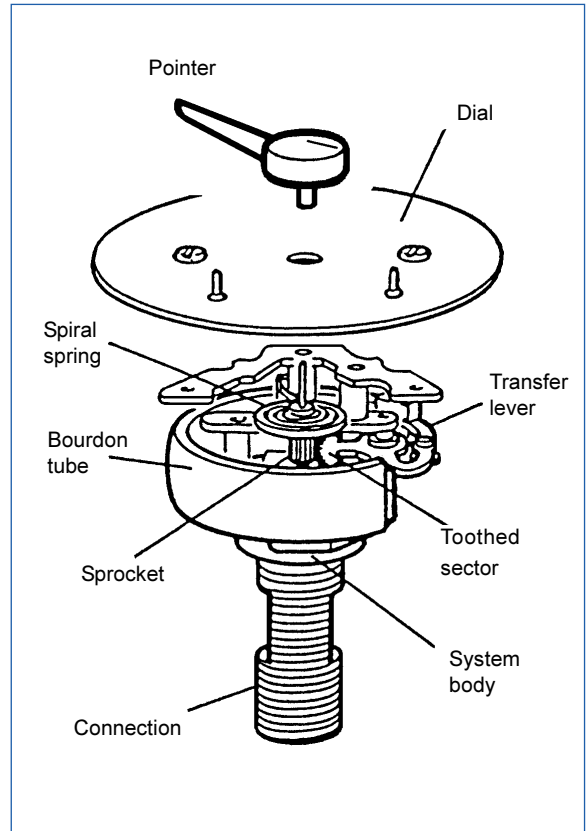

Technical Product Manual

VDO cockpit vision VDO cockpit international

15. Mechanical Pressure Gauge (dia. 52 mm)

15.2 Technical Data

Movement:	Bourdon tube system
Operating temperature:	- 30°C ... + 85°C
Storage temperature:	- 40°C ... + 90°C
Illumination:	1 light bulb 12 V, 2 W or (option) 24 V, 2 W , 2 colour caps, green and red
Protection:	IP64 DIN 40050 from the front
Vibration resistance:	max. 1g eff., 25 ... 500 Hz, duration 8 h, f. 1 octave/min.
Nominal position:	NL 0 to NL 90, DIN 16257
Indication accuracy:	± 4 % of the full range for the last 2/3 of the scale

VDO cockpit vision
dia. 52 mm Backlight



Mounting hole: dia. 53mm

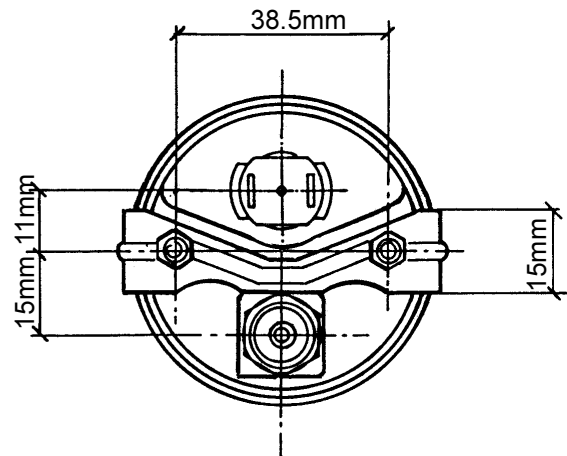
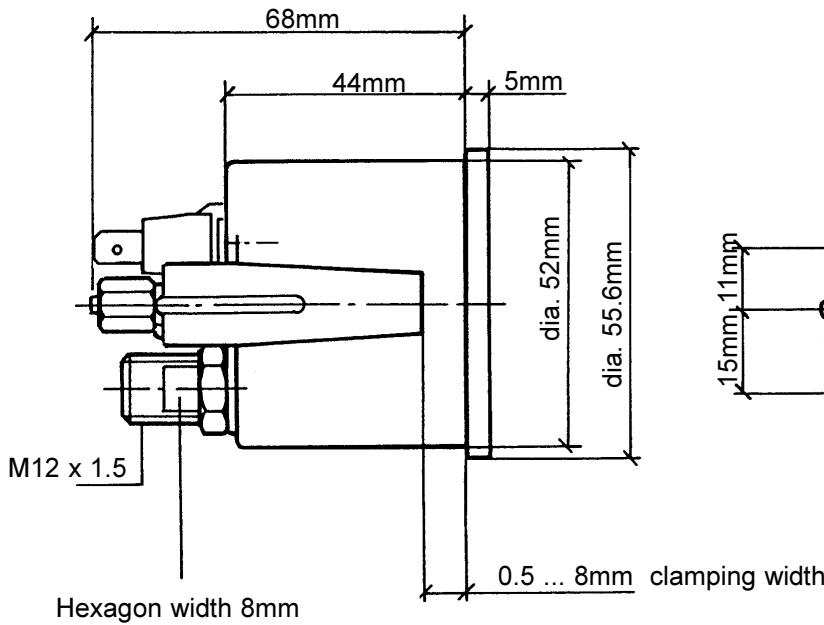

Connecting parts (included):

- a) 1x sleeve for pressure hose
- b) 1x clamp-on termination
- c) 1x union nut (M12 x 1.5, hexagon width 14mm)

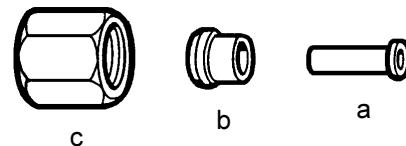

Technical Product Manual

VDO cockpit vision VDO cockpit international

15. Mechanical Pressure Gauge (dia. 52 mm)

15.2 Technical Data

Movement:	Bourdon tube system
Operating temperature:	- 30°C ... + 85°C
Storage temperature:	- 40°C ... + 90°C
Illumination (option):	1 light bulb 12 V, 2 W or 24 V, 2 W
Protection:	IP40 DIN 40050 from the front
Vibration resistance:	max. 1g eff., 25 ... 500 Hz, duration 8 h, f. 1 octave/min.
Nominal position:	NL 0 to NL 90, DIN 16257
Indication accuracy:	± 4 % of the full range for the last 2/3 of the scale

VDO cockpit international
dia. 52 mm Floodlight



Mounting hole: dia. 53mm

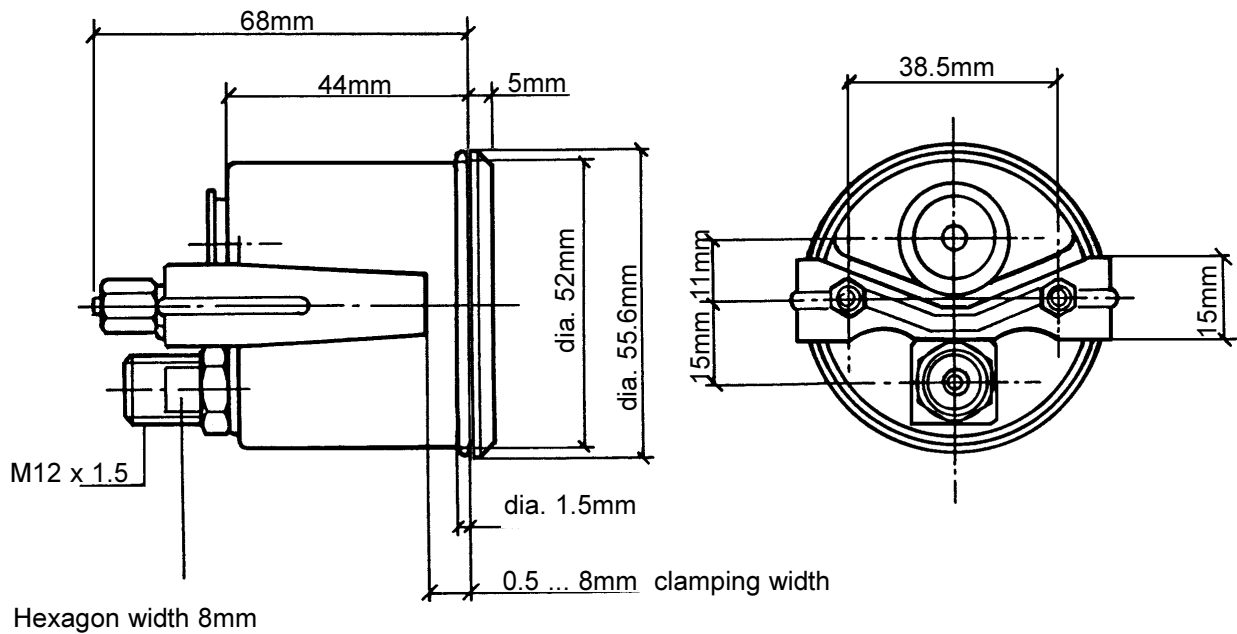

Hexagon width 8mm

Connecting parts (included):

- a) 1x sleeve for pressure hose
- b) 1x clamp-on termination
- c) 1x union nut (M12 x 1.5, hexagon width 14mm)

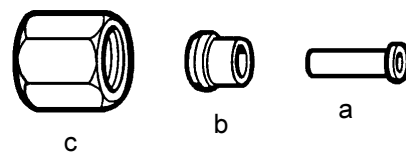

Technical Product Manual

VDO cockpit vision VDO cockpit international

15. Mechanical Pressure Gauge (dia. 52 mm)

15.3 Instruments Survey

VDO cockpit vision (Backlight) dia. 52 mm

Part No. 150-015-. . .

Dial		Special feature	Part No.
Range	Imprint		
0 ... 3 bar	Turbo bar	with illumination 12 V metal housing	001K

VDO cockpit international (Floodlight) dia. 52 mm

Part No. 150-035-. . .

Dial		Special feature	Part No.
Range	Imprint		
- 1 ... 1.5 bar	bar	without illumination	001G
0 ... 2 bar	bar	without illumination	002G
0 ... 7 bar	bar	without illumination	004G
0 ... 10 bar	bar	without illumination	006G
0 ... 16 bar	bar	without illumination	007G
0 ... 25 bar	bar	without illumination	008G
0 ... 30 bar	bar	without illumination	009G
0 ... 7 x 100 kPa	kPa x 100	without illumination	019G
0 ... 10 x 100 kPa	kPa x 100	without illumination	020G
0 ... 25 x 100 kPa	kPa x 100	without illumination	022G
0 ... 10 bar	bar	with illumination 12 V, white pointer, without mounting parts	025C

Technical Product Manual

VDO cockpit vision VDO cockpit international

16. Mechanical Temperature Gauge (dia. 52 mm)

(only for VDO cockpit international)

Contents

Page

16.1 General informations	16 -2
16.2 Technical data	16 -4
16.3 Adaptors for dry probe	16 -5
16.4 Instruments survey	16 -6

Installations instructions

999-165-021: VDO cockpit international

See file 'Installation Instructions (MA)'.

Technical Product Manual

VDO cockpit vision VDO cockpit international

16. Mechanical Temperature Gauge (dia. 52 mm)

(only for VDO cockpit international)

16.1 General Informations

The mechanical temperature gauge has been designed for land-bound vehicles or stationary systems only (exception: motorcycles).

The instrument has an analog display for oil or coolant or air temperature.

A dry probe is through a capillary tube fixed connected with the indicating instrument.

Installation on the measuring point with dry probe or additional adaptor (not included).



The lamp socket (not included) is clipped in. To replace the lamp bulb, carefully, with the thumb, push the lamp holder out to the side.

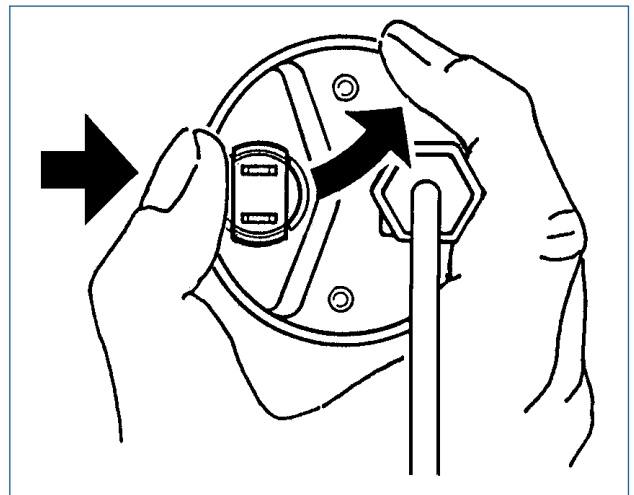

Technical Product Manual

VDO cockpit vision VDO cockpit international

16. Mechanical Temperature Gauge (dia. 52 mm)

(only for VDO cockpit international)

16.1 Genral Informations

Designation of function

Movement: vapour pressure system

The temperature measurement applies the principle of phase change of a liquid evaporating in the corresponding temperature range.

The liquid is contained in the measuring system. The sensor is connected to the temperature indicating system by a capillary tube, thereby constituting a closed system with constant volume. This means that the vapour pressure in the system is a direct function of the temperature at the sensor. The vapour pressure is applied to the bourdon tube of the temperature measuring system. The tube deflection is indicated by a pointer on a dial graduated in temperature values.

The circular bourdon tube with nearly oval section is soldered to the system body at one side. A port connects the tube inside to the system body on the connection. The capillary tube connecting sensor and measuring instrument is soldered into this connection. The free end of the bourdon tube carries a lever, which transfers the bourdon tube end deflection (proportional to the pressure) to a toothed sector.

This toothed sector is engaged in a sprocket, which converts the deflection of the bourdon tube to a rotation and a pointer deflection. Backlash of gears and bearings in the transmission system is compensated by a spiral spring.

The capillary tube between indicating instrument and sensor is covered by a protective braid to prevent bending and friction damages as well as breaks caused by vibration.

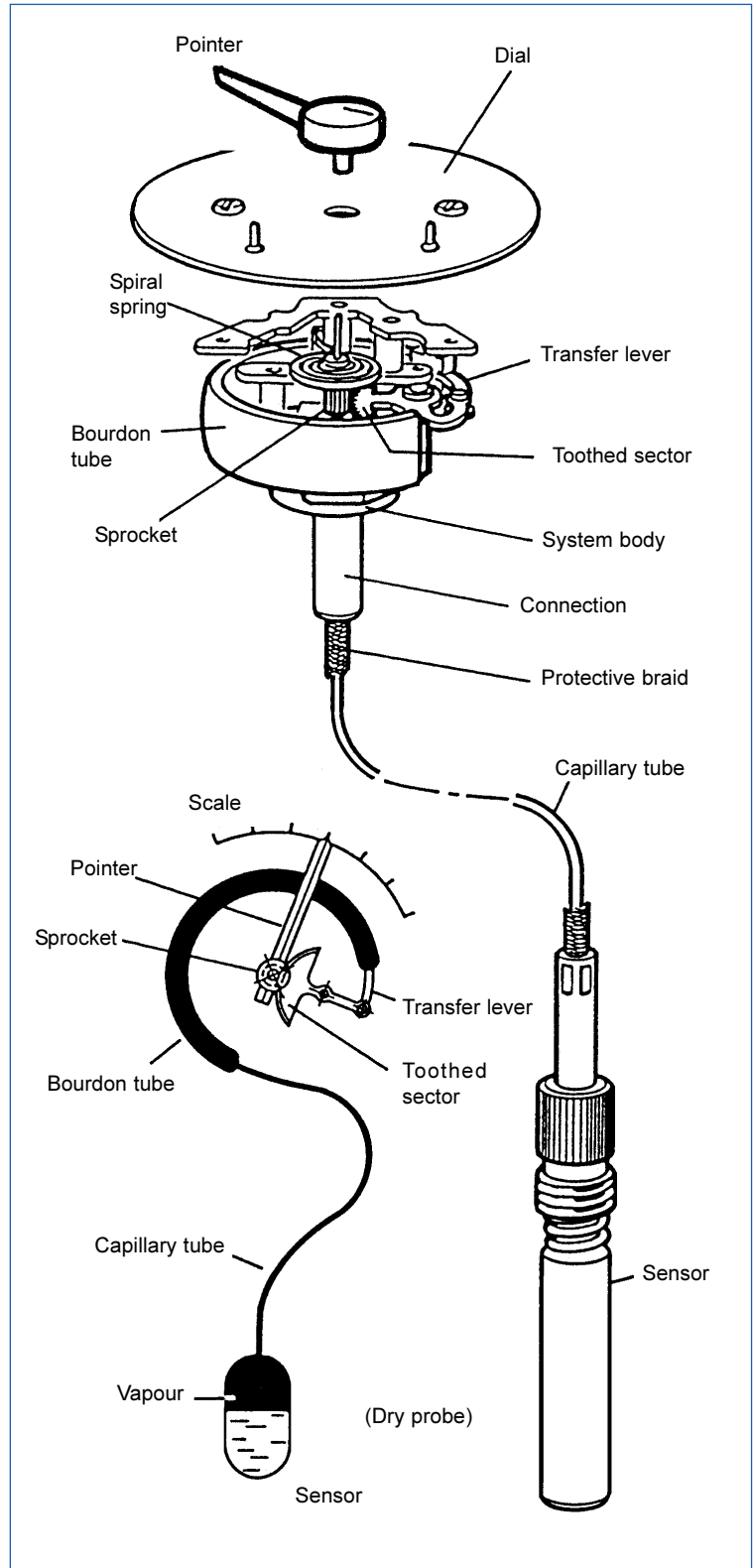

Technical Product Manual

VDO cockpit vision VDO cockpit international

16. Mechanical Temperature Gauge (dia. 52 mm)

(only for VDO cockpit international)

16.2 Technical Data

Movement:	Vapour pressure system
Operating temperature:	- 30°C ... + 85°C
Storage temperature:	- 40°C ... + 90°C
Illumination (option):	1 light bulb 12 V, 2 W or 24 V, 2 W
Protection:	IP64 DIN 40050 from the front
Vibration resistance:	max. 1g eff., 25 ... 500 Hz, duration 8 h, f: 1 octave/min.
Nominal position:	NL 0 to NL 90, DIN 16257
Indication accuracy:	± 4 % of the full range for the last 2/3 of the scale

VDO cockpit international

dia.52 mm

Floodlight

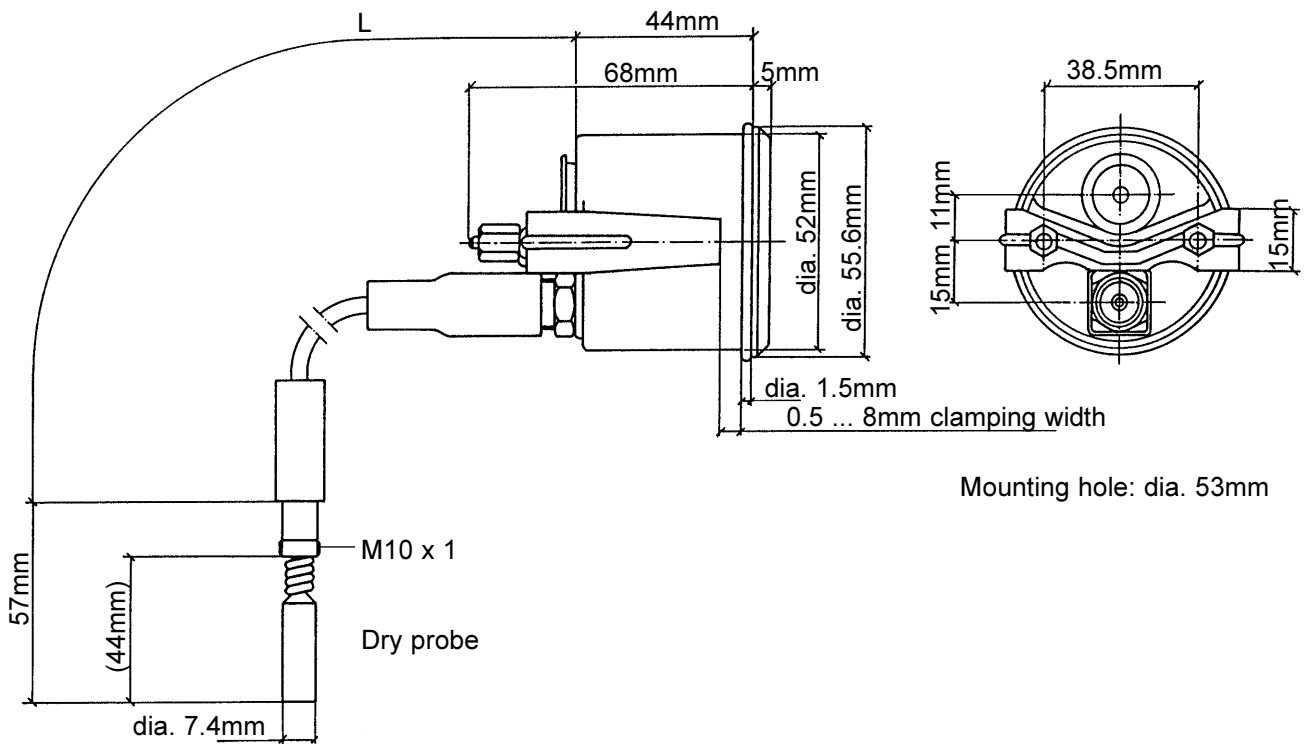
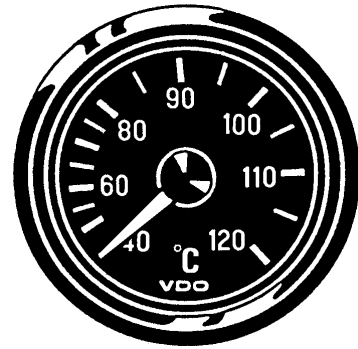

Mounting hole: dia. 53mm

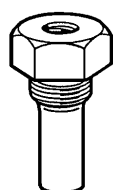

Adaptor for dry probe (not included)

or

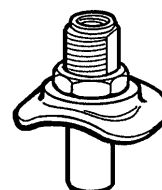

Hose adaptor for dry probe (not included)

Technical Product Manual

VDO cockpit vision VDO cockpit international

16. Mechanical Temperature Gauge (dia. 52 mm)

(only for VDO cockpit international)

16.3 Adaptors For Dry Probe

The mounting of the dry probe on the measuring point followed with a adaptor (not included), which is be screwed into a threaded hole.

If the connection thread is cylindrical, a sealing washer or a sealing ring made of copper must be fitted.



The maximum torque (Nm max.) specified for the thread into which the adaptor is to be screwed must be observed in any case!

Ask for the maximum torque (Nm max.) from the engine manufacturer, equipment manufacturer or car manufacturer.

Non-observance of the maximum tightening torque specified for the threaded hole in each instance can result in damage to the vehicle, engine or equipment system.

Thread	Nm max. (the load-bearing capacity of connection fitting)	Part No.	
R 1/2	30	800-005-029	
M14 x 1.5	20	800-005-030	
M16 x 1.5	30	800-005-031	
M18 x 1.5	30	800-005-032	
R 3/8	30	800-005-033	
5/8 - 18 NF-3	20	800-005-034	
1/8 - 27 NPTF	10	800-005-036	
Hose adaptor for dry probe		800-005-035	

Technical Product Manual

VDO cockpit vision VDO cockpit international

16. Mechanical Temperature Gauge (dia. 52 mm)

(only for VDO cockpit international)

16.4 Instruments Survey

VDO cockpit international (Floodlight) dia. 52 mm

Part No. 180-035- . .

Dial		Special feature	Part No.
Range	Imprint		
40 ... 120 °C	°C	L 1600 + 106 mm	002G
40 ... 120 °C	°C	L 2600 + 160 mm	004G
40 ... 120 °C	°C	L 4000 + 160 mm	005G
40 ... 120 °C	°C	L 6000 + 188 mm	006G
40 ... 150 °C	°C	L 1600 + 106 mm	007G
40 ... 150 °C	°C	L 2600 + 160 mm	008G
40 ... 150 °C	°C	L 4000 + 160 mm	009G
40 ... 150 °C	°C	L 6000 + 188 mm	010G

Technical Product Manual

VDO cockpit vision VDO cockpit international

17. Final Assembly

Contents	Page
17.1 General instructions	17 - 2
17.2 Tools, test accessories, programming accessories	17 - 3
17.2.1 Dial press with accessories	17 - 3
17.2.2 Combination press for pointer and stop pin with accessories	17 - 4
17.2.3 Universal press (for pointer and stop pin and bezel closing) with accessories	17 - 6
17.2.4 Bezel closing kit	17 - 8
17.2.5 Test cables kit	17 - 9
17.2.6 Software	17 - 10
17.2.7 Workshop stamp kit	17 - 11
17.3 Modules, parts	17 - 12
VDO cockpit vision - backlight -	
17.3.1 Dia. 52 mm (pressure gauge, temperature gauge, fuel level gauge, voltmeter)	17 - 12
17.3.2 Dia. 80 mm / dia. 100 mm (electronic tachometer)	17 - 14
17.3.3 Dia. 80 mm / dia. 100 mm (electronic speedometer)	17 - 16
VDO cockpit international - floodlight -	
17.3.4 Dia. 52 mm (pressure gauge, temperature gauge, fuel level gauge, voltmeter)	17 - 18
17.3.5 Dia. 80 mm / dia. 100 mm (electronic tachometer)	17 - 21
17.3.6 Dia. 80 mm / dia. 100 mm (electronic speedometer)	17 - 23
17.3.7 Dia. 80 mm / dia. 100 mm (electronic tachometer with operating hours counter)	17 - 25
17.4 Assembly sequence	17 - 27
17.4.1 Instruments 100 mm dia. or 80 mm dia. with stepper motor (electronic speedometer, electronic tachometer with operating hours counter)	17 - 27
17.4.2 Instruments 100 mm dia. or 80 mm dia. with Ke movement (electronic tachometer)	17 - 36
17.4.3 Instruments 52 mm dia. VDO cockpit vision - backlight - (pressure gauge, temperature gauge, fuel level gauge, voltmeter)	17 - 44
17.4.4 Instruments 52 mm dia. VDO cockpit international - floodlight - (pressure gauge, temperature gauge, fuel level gauge, voltmeter)	17 - 51

Technical Product Manual

VDO cockpit vision VDO cockpit international

17. Final Assembly

17.1 General Instructions

In addition to the VDO instrument assemblies for which production code numbers have been assigned, customized instrument assemblies can be carried out in workshops by trained technical staff.

In the latter case, the following instructions have to be observed:



Do not use modules or components other than the genuine VDO ones listed in the product manual!



Assembly must be carried out only with the approved tools and test accessories listed in the product manual!



After workshop assembly, the instruments concerned will have to be marked as follows: Part No., Workshop No., and Date.



Instruments for which production code numbers have been assigned must never be changed in any way whatsoever (modified, rebuilt etc.)!

SiemensVDO Automotive AG does not assume any liability or warranty for work which does not comply with the above.

Technical Product Manual

VDO cockpit vision VDO cockpit international

17. Final Assembly

17.2 Tools, Test Accessories, Programming Accessories

17.2.1 Dial Press With Accessories

Part No. X12-015-001-001

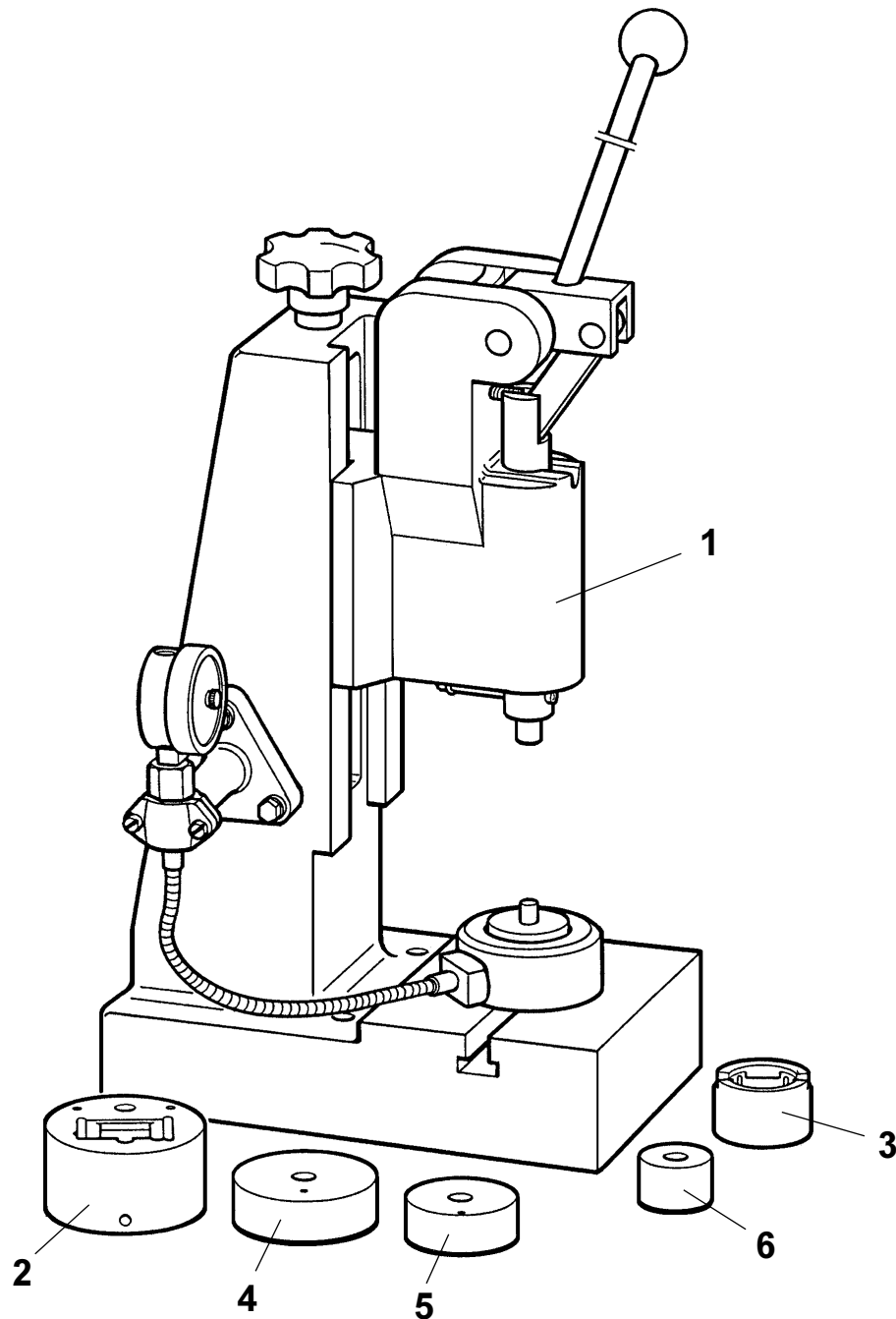

Pos.	Designation	
1	Dial press	1x
2	Light conductor receiver 80 mm and 100 mm	1x
3	Light conductor receiver 52 mm	1x
4	Stamp 100 mm	1x
5	Stamp 80 mm	1x
6	Stamp 52 mm	1x

Technical Product Manual

VDO cockpit vision VDO cockpit international

17. Final Assembly

17.2 Tools, Test Accessories, Programming Accessories

17.2.2 Combination Press For Pointer And Stop Pin

Part No. X12-015-002-001

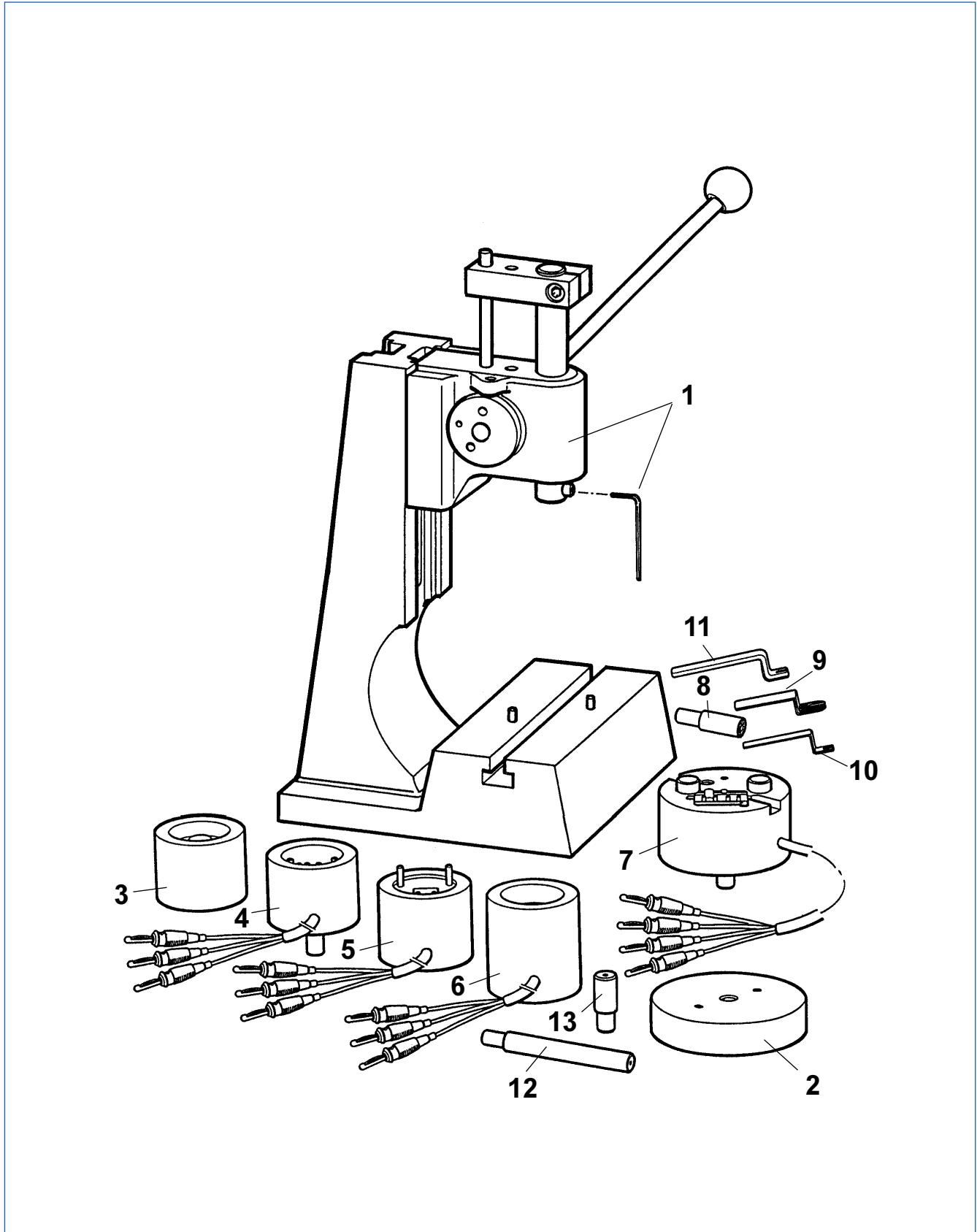

Technical Product Manual

VDO cockpit vision VDO cockpit international

17. Final Assembly

17.2 Tools, Test Accessories, Programming Accessories

17.2.2 Combination Press For Pointer And Stop Pin

Part No. X12-015-002-001

Pos.	Designation	
1	Combination press (with screw driver)	1x
2	Support block, 28 mm high	1x
3	Support, 52 mm, ammeter	1x
4	Support with current supply wire, 52 mm (Rüthi)	1x
5	Support with current supply wire, 52 mm vision (Malaysia)	1x
6	Support with current supply wire, 52 mm international (Malaysia)	1x
7	Support with current supply wire, 80 mm and 100 mm (Rüthi)	1x
8	Universal stamp	1x
9	Pointer spacer 0.5 mm	1x
10	Pointer spacer 0.3 mm	1x
11	Pointer spacer 3 mm	1x
12	Rivet stamp	1x
13	Stop pin receiver	1x

Technical Product Manual

VDO cockpit vision VDO cockpit international

17. Final Assembly

17.2 Tools, Test Accessories, Programming Accessories

17.2.3 Universal Press (for pointer and stop pin and bezel closing) With Accessories

Part No. X12-015-003-001

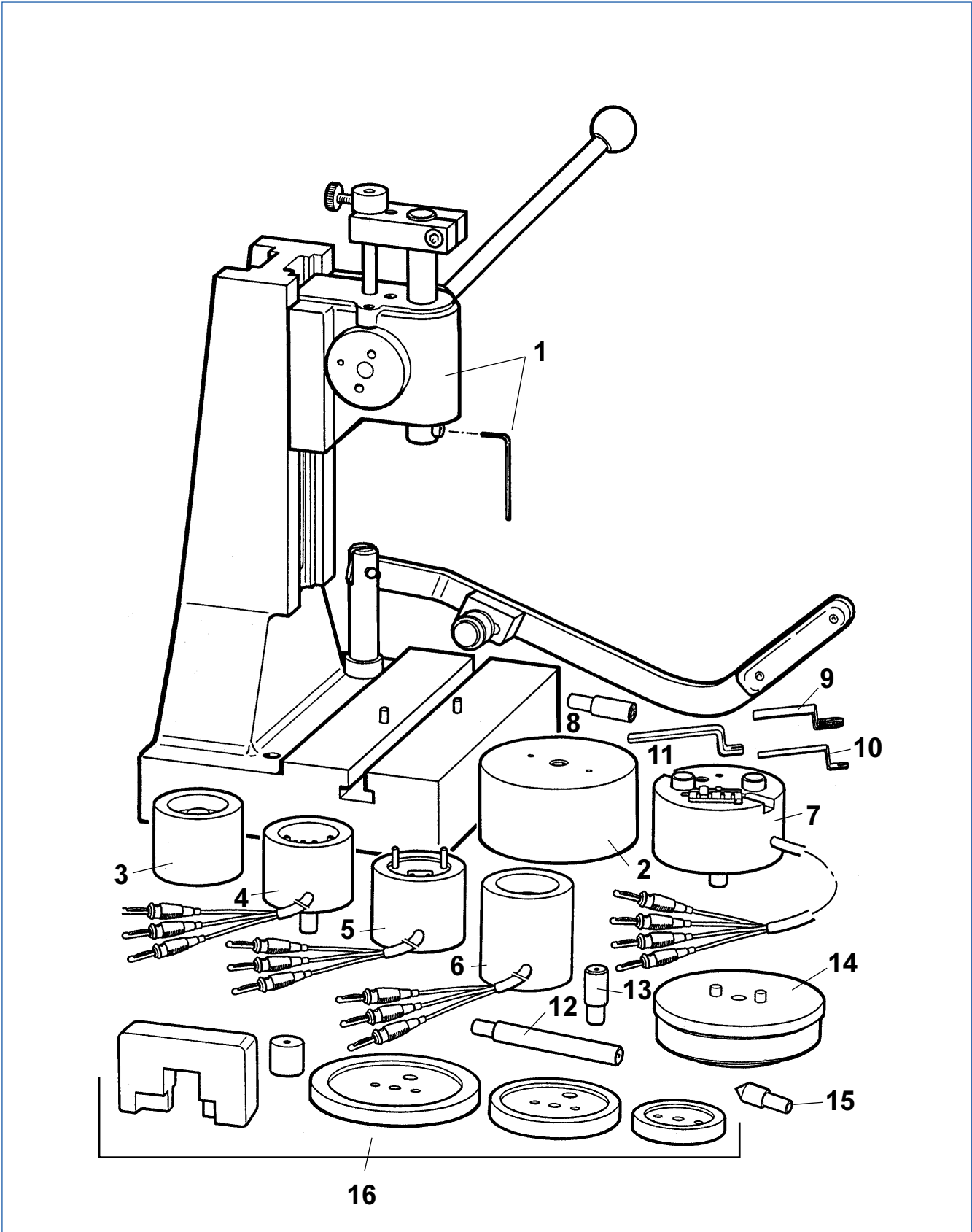

Technical Product Manual

VDO cockpit vision VDO cockpit international

17. Final Assembly

17.2 Tools, Test Accessories, Programming Accessories

17.2.3 Universal Press (for pointer and stop pin and bezel closing) With Accessories

Part No. X12-015-003-001

Pos.	Designation		Part No.
1	Universal press (with screw driver)	1x	
2	Support block, 56 mm high	1x	
3	Support, 52 mm, ammeter	1x	
4	Support with current supply wire, 52 mm (Rüthi)	1x	
5	Support with current supply wire, 52 mm vision (Malaysia)	1x	
6	Support with current supply wire, 52 mm international (Malaysia)	1x	
7	Support with current supply wire, 80 mm and 100 mm (Rüthi)	1x	
8	Universal stamp	1x	
9	Pointer spacer 0.5 mm	1x	
10	Pointer spacer 0.3 mm	1x	
11	Pointer spacer 3 mm	1x	
12	Rivet stamp	1x	
13	Stop pin receiver	1x	
14	Turned receiver for bezel closing die	1x	
15	Centering stud	1x	
16	Bezel closing kit	1x	X12-015-004-001

Technical Product Manual

VDO cockpit vision VDO cockpit international

17. Final Assembly

17.2 Tools, Test Accessories, Programming Accessories

17.2.4 Bezel Closing Kit

Part No. X12-015-004-001

Pos.	Designation	
1	Centering block	1x
2	Bridge	1x
3	Bezel closing die 52 mm	1x
4	Bezel closing die 80 mm	1x
5	Bezel closing die 100 mm	1x

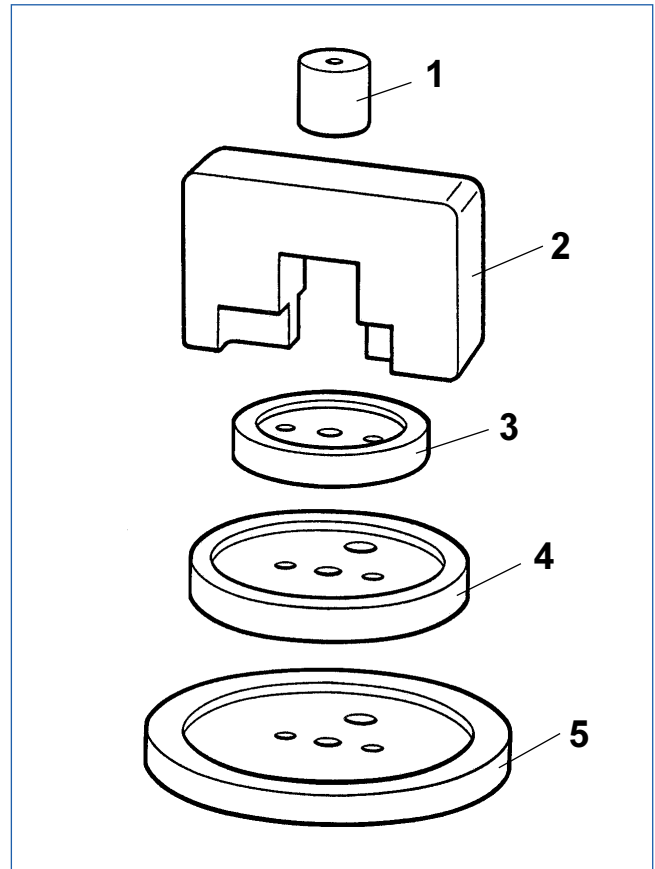

Technical Product Manual

VDO cockpit vision VDO cockpit international

17. Final Assembly

17.2 Tools, test Accessories, Programming Accessories

17.2.5 Test Cables Kit

Part No. X12-019-101-001

consisting of:

- 1 test cable No. 1
- 1 test cable No. 2
- 1 test cable No. 3
- 1 measuring wire

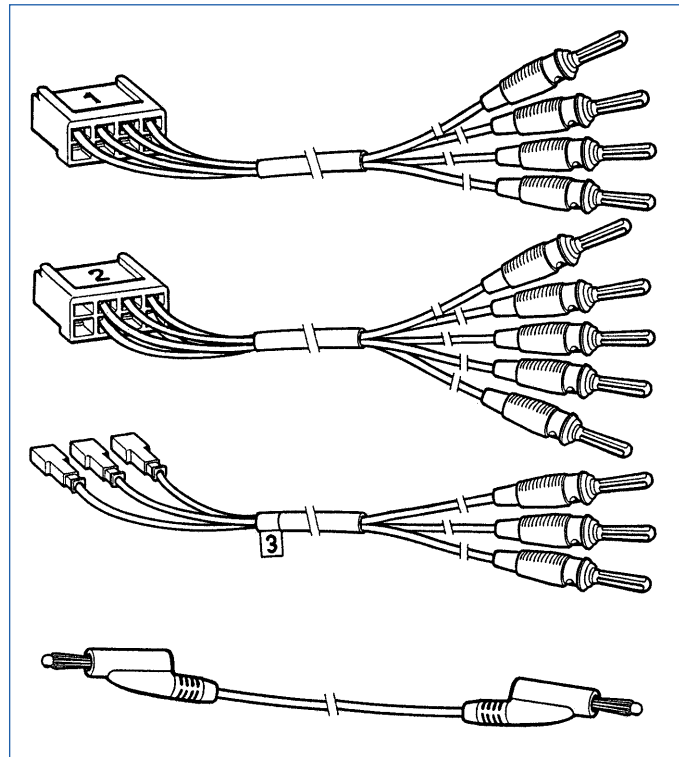

Information:

For testing of the electronic tachometer with operating hours counter, which is connected with the pin 5 (permanent positive pole 12V/24V), the test cable No. 2 must be extended.

Connect a wire dia. 0.75 mm² (750 mm long) with an usual commercial cluster plug and a spade connector 6.3 x 0.8 mm with latch tongue (part No. X11-000-002-021).

Put the wire in the terminal 5 of the spade connector housing. The spade connector must engage with an audible click.

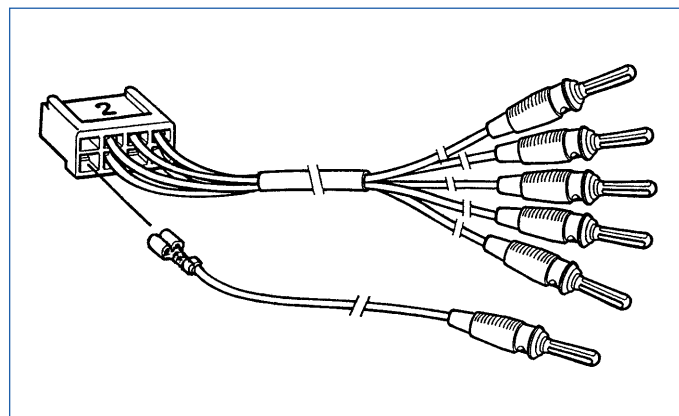

Technical Product Manual

VDO cockpit vision VDO cockpit international

17. Final Assembly

17.2 Tools, Test Accessories, Programming Accessories

17.2.6 Software

System requirements:

MS-DOS compatible PC,
processor 386SX or better,
mathematical coprocessor (recommended),
MS-DOS 5.0 or more recent,
one serial port COM 1 or COM 2,
one parallel port LPT1 (recommended),
3.5" diskette drive,
1MB hard disk capacity,
380 kB free memory,
mouse (recommended).

**Software package (full version) with diskette,
programming cable and individual workshop
stamp kit** Part No. X12-019-105-001

Programming of all electronic tachometers with operating hours counter and electronic speedometers of the VDO cockpit vision und VDO cockpit international series.

The following parameters can be changed with this software:

- Measuring range
- Frequency or distance/pulse ratio
- Disable programming by pushbutton
- Operating hours (for tachometer)
- Total distance (for speedometer)
- Electronic operating hours counter threshold
- Pointer zero position

A diagnosis, storage and documentation of data sets is possible in addition. The use is simplified by an online help system.

Software package with diskette and programming cable
Part No. X12-019-104-001

Programming of all electronic tachometers with operating hours counter and electronic speedometers of the VDO cockpit vision und VDO cockpit international series.

The following parameters can be changed with this software:

- Frequency or distance/pulse ratio
- Operating hours (for tachometer)
- Total distance (for speedometer)

A diagnosis, storage and documentation of data sets is possible in addition. The use is simplified by an online help system.

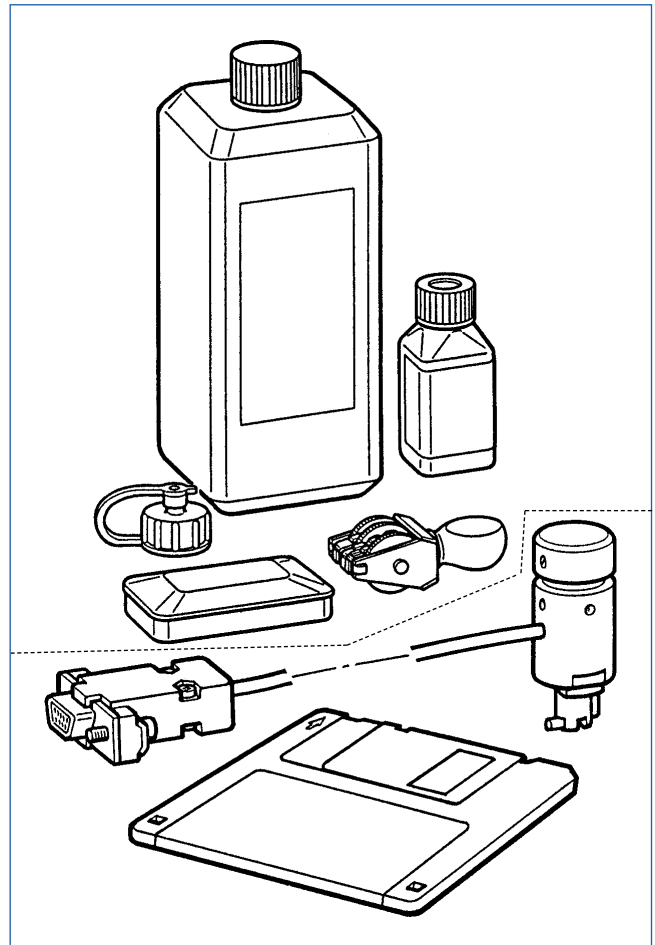

Technical Product Manual

VDO cockpit vision VDO cockpit international

17. Final Assembly

17.2 Tools, Test Accessories, Programming Accessories

17.2.7 Workshop Stamp Kit

Part No. X12-015-005-001

consisting of:

- 1 individual workshop stamp (tapes stamp)
lettering size 3mm
- 1 ink-pad
- 1 special endorsing ink R9
green, 50 ml
- 1 solvent and thinner for
special endorsing ink R9, 250 ml

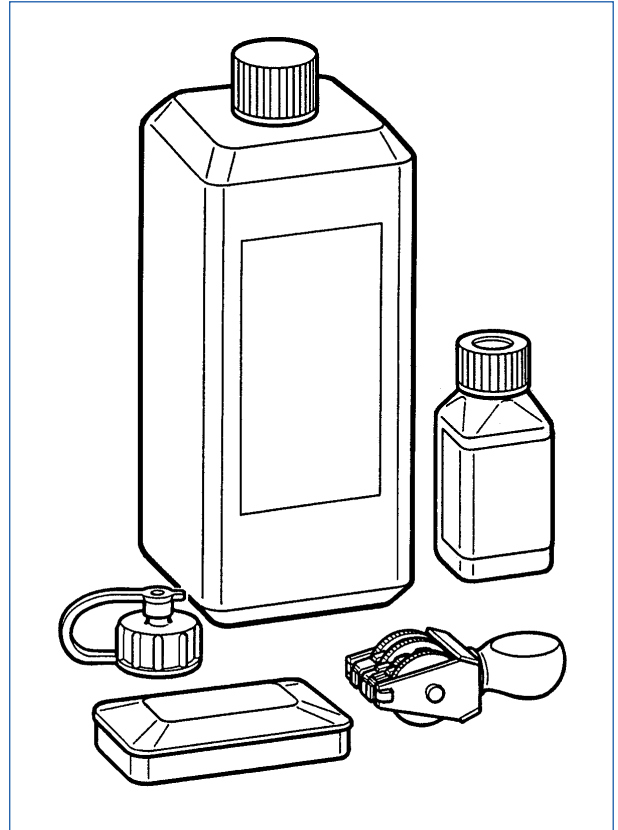

Technical Product Manual

VDO cockpit vision VDO cockpit international

17. Final Assembly

17.3 Modules, Parts

17.3.1 VDO cockpit vision, dia. 52 mm (Pressure Gauge, Temperature Gauge, Fuel Level Gauge, Voltmeter)

- Backlight -

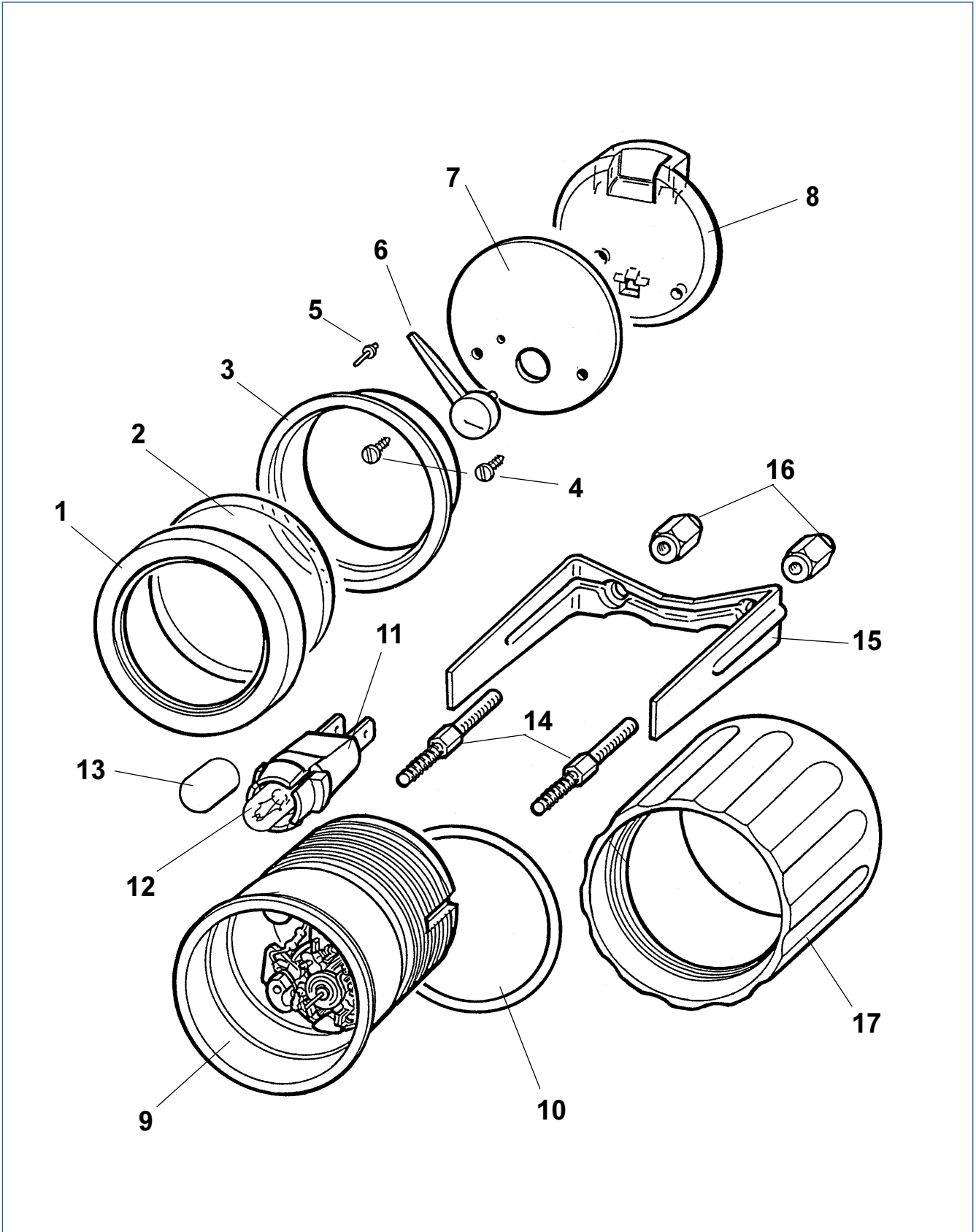

Technical Product Manual

VDO cockpit vision VDO cockpit international

17. Final Assembly

17.3 Modules, Parts

17.3.1 VDO cockpit vision, dia. 52 mm (Pressure Gauge, Temperature Gauge, Fuel Level Gauge, Voltmeter)

- Backlight -

Pos.	Designation	Packaging unit	Part No.
1	Bezel black, flat	100	999-107-001
	Bezel chrome, flat	100	999-107-002
	Bezel black, triangled	100	999-107-003
	Bezel chrome, triangled	100	999-107-004
2	Lens clear	100	999-057-001
	Lens nonreflective	100	999-057-002
3	Deflector	100	999-087-002
4	Dial screw	100	21-180-030-1582
5	Stop pin	100	999-117-001
6	Pointer white	100	999-037-003
	Pointer red	100	999-037-007
7	Dial 5 bar oil pressure	100	999-040-026
	Dial 10 bar oil pressure	100	999-040-027
	Dial 120° C cooling water temperature	100	999-040-035
	Dial 150° C oil temperature	100	999-040-036
	Dial 0 - 1/1 fuel	100	999-040-047
	Dial 0 - 1/1 fuel, adjustable	100	999-040-067
	Dial 12V voltmeter	100	999-040-054
8	Light conductor	100	999-097-001
9	Module 12V fuel	10	888-010-002
	Module 12V fuel, adjustable	10	888-010-004
	Module 12V 150° C	10	888-010-005
	Module 12V 120° C	10	888-010-008
	Module 12V 5 bar, 10 bar	10	888-010-009
	Module 12V voltmeter	10	888-010-010
10	Sealing ring	100	999-115-009
11	Lamp holder	100	999-067-001
12	Light bulb 12V, 2W	100	999-065-001
13	Colour cap red	100	999-115-007
	Colour cap green	100	999-115-008
14	Stud bolt	100	999-120-001
15	Bracket	100	999-077-001
16	Nut	100	999-127-001
17	Clamp ring	100	999-072-001

Technical Product Manual

VDO cockpit vision VDO cockpit international

17. Final Assembly

17.3 Modules, Parts

17.3.2 VDO cockpit vision, dia. 80 mm / dia. 100 mm
(Electronic Tachometer)

- Backlight -

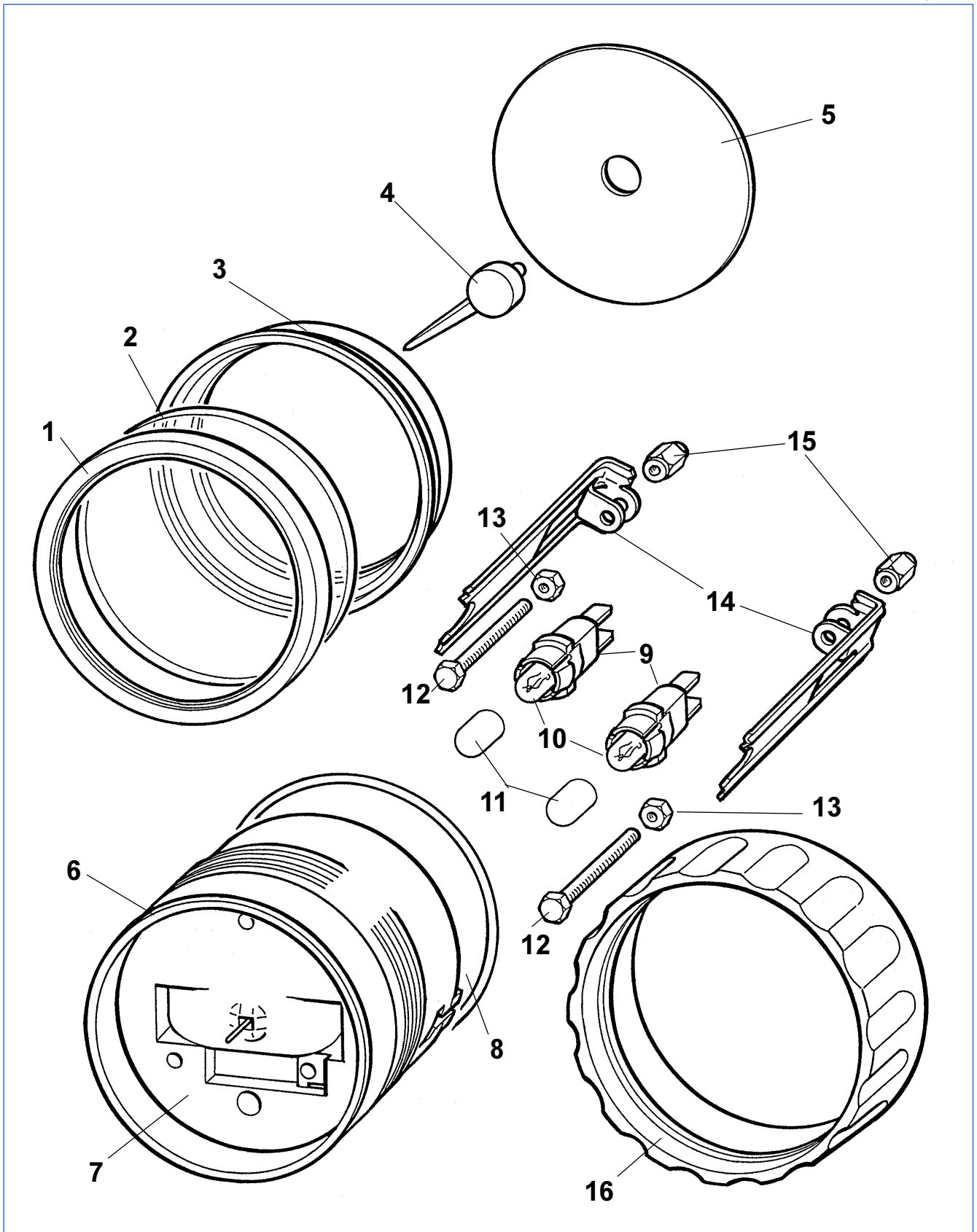

Technical Product Manual

VDO cockpit vision VDO cockpit international

17. Final Assembly

17.3 Modules, Parts

17.3.2 VDO cockpit vision, dia. 80 mm / dia. 100 mm (Electronic Tachometer)

- Backlight -

Pos.	Designation	Packaging unit	Part No.
1	Bezel black, flat dia. 80 mm	100	999-105-009
	Bezel black, flat dia. 100 mm	100	999-105-011
	Bezel black, triangled dia. 80 mm	100	999-105-005
	Bezel chrome, triangled 80 mm	100	999-105-001
	Bezel black, triangled dia. 100 mm	100	999-105-007
	Bezel chrome, triangled dia. 100 mm	100	999-105-003
2	Lens clear dia. 80 mm	100	999-055-001
	Lens clear dia. 100 mm	100	999-055-003
	Lens nonreflective dia. 80 mm	100	999-055-005
	Lens nonreflective dia. 100 mm	100	999-055-007
3	Deflector dia. 80 mm	100	999-085-005
	Deflector dia. 100 mm	100	999-085-007
4	Pointer (Ke) red dia. 80 mm	100	993-747-084-6382
	Pointer (Ke) red dia. 100 mm	100	993-747-087-6382
5	Dial 7000 min ⁻¹ dia. 80 mm	100	999-045-021
	Dial 8000 min ⁻¹ dia. 100 mm	100	999-045-024
	Dial 10000 min ⁻¹ dia. 100 mm	100	999-045-025
6	Module (tacho Ke) 12V 7000 min ⁻¹ dia. 80 mm	10	888-085-005C
	12V 8000 min ⁻¹ dia. 100 mm	10	888-105-004C
	12V 10000 min ⁻¹ dia. 100 mm	10	888-105-005C
7	Light conductor dia. 80 mm	100	999-095-001
	Light conductor dia. 100 mm	100	999-095-002
8	Sealing ring dia. 80 mm	100	999-115-001
	Sealing ring dia. 100 mm	100	999-115-003
9	Lamp holder	100	999-067-001
10	Light bulb 12 V, 2W	100	999-065-001
11	Colour cap red	100	999-115-007
	Colour cap green	100	999-115-008
12	Hex screw	100	999-125-006
13	Hex nut	100	4-077-003-1161
14	Bracket	100	999-125-004
15	Nut	100	999-127-001
16	Clamp ring dia. 80 mm	100	999-071-001
	Clamp ring dia. 100 mm	100	999-071-003

Technical Product Manual

VDO cockpit vision VDO cockpit international

17. Final Assembly

17.3 Modules, Parts

17.3.3 VDO cockpit vision, dia. 80 mm / dia. 100 mm
(Electronic Speedometer)

- Backlight -

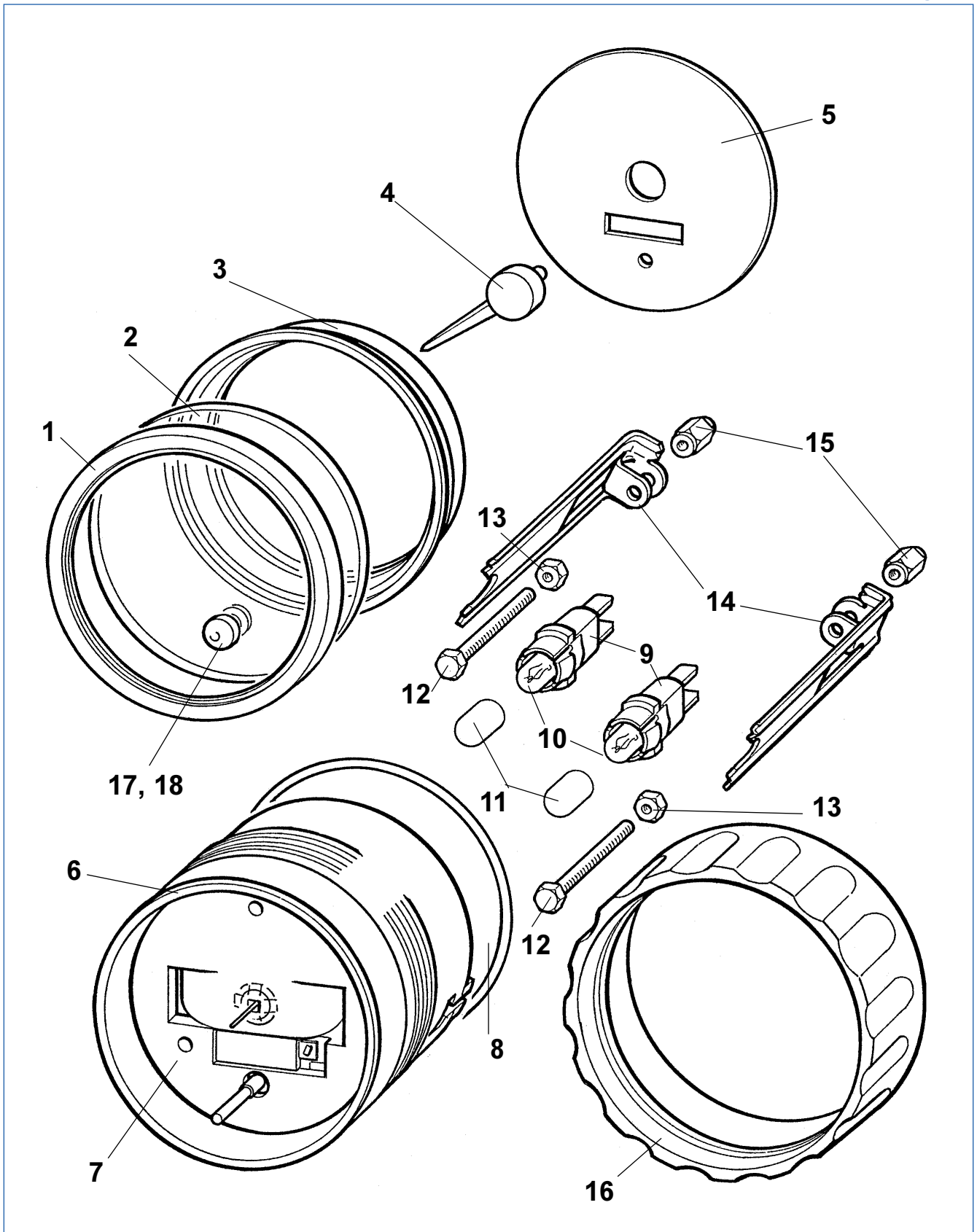

Technical Product Manual

VDO cockpit vision VDO cockpit international

17. Final Assembly

17.3 Modules, Parts

17.3.3 VDO cockpit vision, dia.80 mm / dia. 100 mm (Electronic Speedometer)

- Backlight -

Pos.	Designation	Packaging unit	Part No.
1	Bezel black, flat dia. 80 mm	100	999-105-009
	Bezel black, flat dia. 100 mm	100	999-105-011
	Bezel black, triangled dia. 80 mm	100	999-105-005
	Bezel chrome, triangled dia. 80 mm	100	999-105-001
	Bezel black, triangled dia. 100 mm	100	999-105-007
	Bezel chrome, triangled dia. 100 mm	100	999-105-003
2	Lens (for reset shaft) clear dia. 80 mm	100	999-055-009
	Lens (for reset shaft) clear dia. 100 mm	100	999-055-011
	Lens (for reset shaft) nonreflective dia. 80 mm	100	999-055-013
	Lens (for reset shaft) nonreflective dia. 100 mm	100	999-055-015
3	Deflector dia. 80 mm	100	999-085-005
	Deflector dia. 100 mm	100	999-085-007
4	Pointer (SM) red dia. 80 mm	100	993-747-083-6382
	Pointer (SM) red dia. 100 mm	100	993-747-088-6382
5	Dial 0-200 km/h dia. 80 mm	100	999-045-008
	Dial 0-300 km/h dia. 80 mm	100	999-045-009
	Dial 0-200 km/h dia. 100 mm	100	999-045-014
	Dial 0-300 km/h dia. 100 mm	100	999-045-015
	Dial 0-220 MPH, 0-360 km/h dia. 100 mm	100	999-045-016
6	Module (speedo SM) 12 - 24 V dia. 80 mm	10	888-085-002C
	12 - 24 V dia. 100 mm	10	888-105-002C
7	Light conductor dia. 80 mm	100	999-095-001
	Light conductor dia. 100 mm	100	999-095-002
8	Sealing ring dia. 80 mm	100	999-115-001
	Sealing ring dia. 100 mm	100	999-115-003
9	Lamp holder	100	999-067-001
10	Light bulb 12 V, 2W	100	999-065-001
	Light bulb 24 V, 2W	100	999-065-002
11	Colour cap red	100	999-115-007
	Colour cap green	100	999-115-008
12	Hex screw	100	999-125-006
13	Hex nut	100	4-077-003-1161
14	Bracket	100	999-125-004
15	Nut	100	999-127-001
16	Clamp ring dia. 80 mm	100	999-071-001
	Clamp ring dia. 100 mm	100	999-071-003
17	Rubber cap	100	999-115-005
18	Bushing	100	999-115-010

Technical Product Manual

VDO cockpit vision VDO cockpit international

17. Final Assembly

17.3 Modules, Parts

17.3.4 VDO cockpit international, dia. 52 mm (Pressure Gauge, Temperature Gauge, Fuel Level Gauge, Voltmeter) - Floodlight -

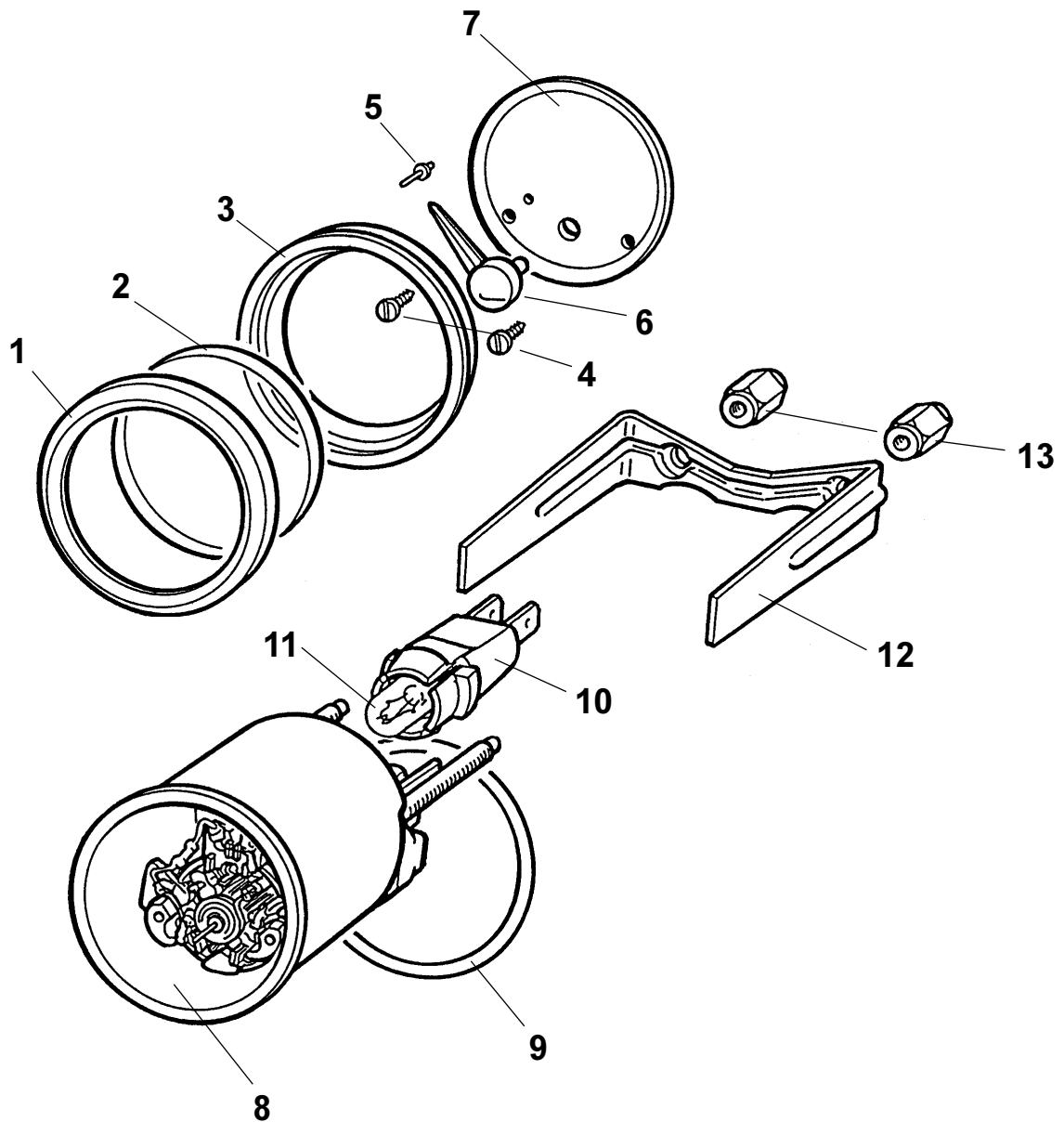

Technical Product Manual

VDO cockpit vision VDO cockpit international

17. Final Assembly

17.3 Modules, Parts

17.3.4 VDO cockpit international, dia. 52 mm (Pressure Gauge, Temperature Gauge, Fuel Level Gauge, Voltmeter) - Floodlight -

Pos.	Designation	Packaging unit	Part No.
1	Bezel black, flat	100	999-107-001
	Bezel chrome, flat	100	999-107-002
	Bezel black, triangled	100	999-107-003
	Bezel chrome, triangled	100	999-107-004
2	Lens clear	100	999-057-001
	Lens nonreflective	100	999-057-002
3	Deflector	100	999-087-001
4	Dial screw	100	21-180-030-1582
5	Stop pin	100	999-117-001
6	Pointer red	100	999-037-001
	Pointer white	100	999-037-005
7	Dial 5 bar engine oil pressure	100	999-040-003
	Dial 10 bar engine oli pressure	100	999-040-004
	Dial 25 bar transmission oil pressure	100	999-040-005
	Dial 120° C cooling water temperature	100	999-040-012
	Dial 150° C engine oil temperatur	100	999-040-013
	Dial 12V voltmeter	100	999-040-018
	Dial 24V voltmeter	100	999-040-019
	Dial 200° C	100	999-040-020
	Dial 0 - 1/1 fuel	100	999-040-024
	Dial 10 bar brake pressure	100	999-040-049
	Dial 120° C hydraulic oil temperature	100	999-040-051
	Dial 150° C transmission oil temperature	100	999-040-052
	Dial 0 - 1/1 fuel, adjustable	100	999-040-066
	8	Module 12V fuel	10
Module 12V fuel, adjustable		10	888-030-004
Module 12V 150° C		10	888-030-005
Module 12V 120° C		10	888-030-008
Module 12V 5, 10, 25 bar, 10 bar brake pressure		10	888-030-009
Module 12V 200° C		10	888-030-010
Module 12V voltmeter		10	888-030-016
Module 24V voltmeter		10	888-040-001
Module 24V fuel		10	888-040-003
Module 24V fuel, adjustable		10	888-040-005
Module 24V 150° C		10	888-040-006
Module 24V 120° C	10	888-040-009	
Module 24V 5, 10, 25 bar, 10 bar brake pressure	10	888-040-010	
Module 24V 200° C	10	888-040-011	
9	Sealing ring	100	999-115-009

Technical Product Manual

VDO cockpit vision VDO cockpit international

17. Final Assembly

17.3 Modules, Parts

17.3.5 VDO cockpit international, dia. 80 mm / dia. 100 mm
(Electronic Tachometer)

- Floodlight -

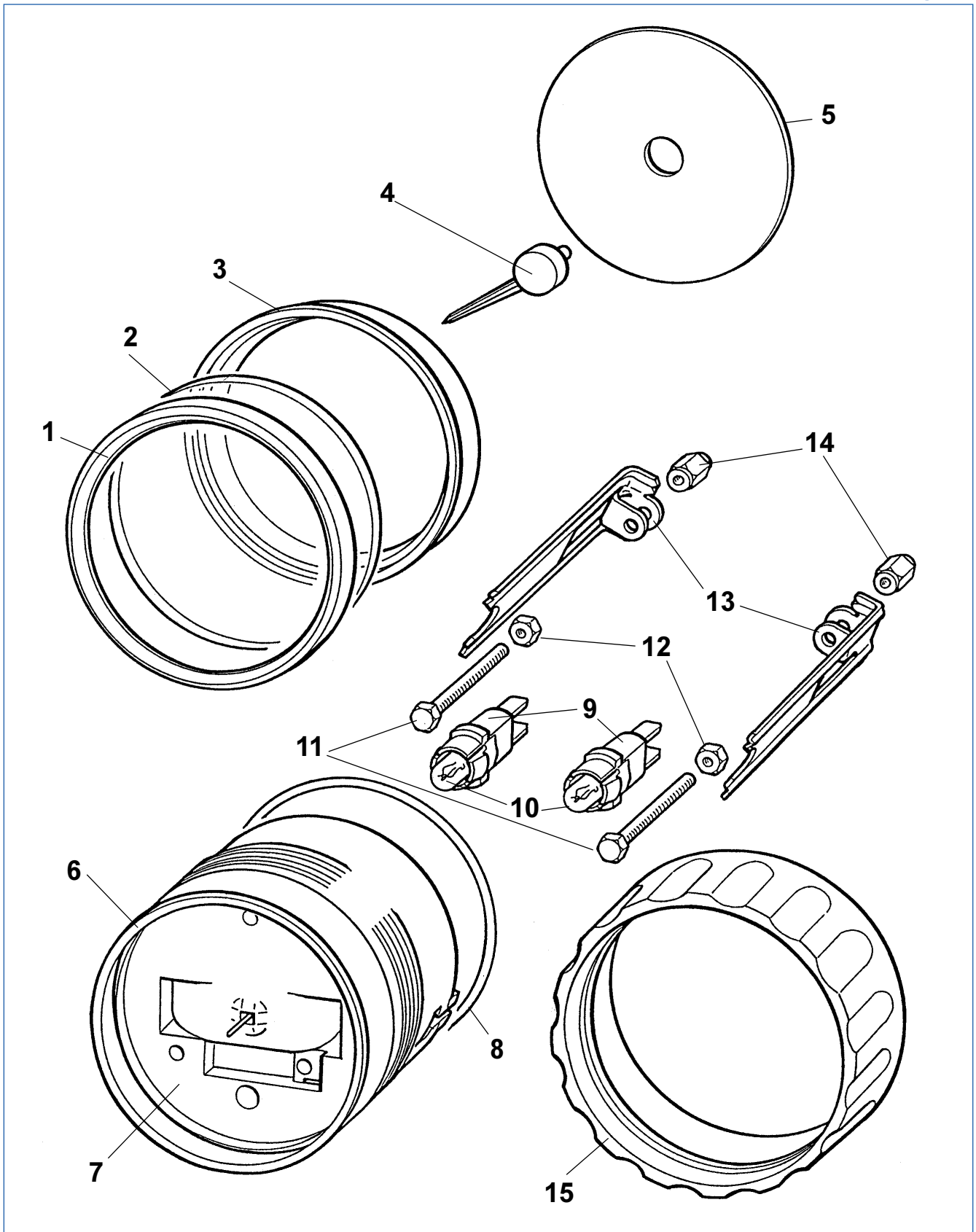

Technical Product Manual

VDO cockpit vision VDO cockpit international

17. Final Assembly

17.3 Modules, Parts

17.3.5 VDO cockpit international, dia. 80 mm / dia. 100 mm (Electronic Tachometer)

-Floodlight -

Pos.	Designation	Packaging unit	Part No.
1	Bezel black, flat dia. 80 mm	100	999-105-009
	Bezel black, flat dia. 100 mm	100	999-105-011
	Bezel black, triangled dia. 80 mm	100	999-105-005
	Bezel chrome, triangled dia. 80 mm	100	999-105-001
	Bezel black, triangled dia. 100 mm	100	999 105 007
	Bezel chrome, triangled dia. 100 mm	100	999-105-003
2	Lens clear dia. 80 mm	100	999-055-001
	Lens clear dia. 100 mm	100	999-055-003
	Lens nonreflective dia. 80 mm	100	999-055-005
	Lens nonreflective dia. 100 mm	100	999-055-007
3	Deflector dia. 80 mm	100	999-085-001
	Deflector dia. 100 mm	100	999-085-003
4	Pointer (Ke) red dia. 80 mm	100	88-488-121-5185
	Pointer (Ke) red dia. 100 mm	100	88-488-123-5185
5	Dial 3000 min ⁻¹ dia. 80 mm	100	999-045-017
	Dial 4000 min ⁻¹ dia. 80 mm	100	999-045-018
	Dial 7000 min ⁻¹ dia. 80 mm	100	999-045-019
	Dial 3000 min ⁻¹ dia. 100 mm	100	999-045-020
6	Module (tacho Ke) 12V 3000/4000 min ⁻¹ dia. 80 mm	10	888-085-003C
	12V 7000 min ⁻¹ dia. 80 mm	10	888-085-004C
	24V 3000/4000 min ⁻¹ dia. 80 mm	10	888-085-006C
	24V 7000 min ⁻¹ dia. 80 mm	10	888-085-007C
	12V 3000 min ⁻¹ dia. 100 mm	10	888-105-003C
	24V 3000 min ⁻¹ dia. 100 mm	10	888-105-006C
7	Light conductor dia. 80 mm	100	999-095-004
	Light conductor dia. 100 mm	100	999-095-005
8	Sealing ring dia. 80 mm	100	999-115-001
	Sealing ring dia. 100 mm	100	999-115-003
9	Lamp holder	100	999-067-001
10	Light bulb 12 V, 2 W	100	999-065-001
	Light bulb 24 V, 2 W	100	999-065-002
11	Hex screw	100	999-125-006
12	Hex nut	100	4-077-003-1161
13	Bracket	100	999-125-004
14	Nut	100	999-127-001
15	Clamp ring dia. 80 mm	100	999-071-001
	Clamp ring dia. 100 mm	100	999-071-003

Technical Product Manual

VDO cockpit vision VDO cockpit international

17. Final Assembly

17.3 Modules, Parts

17.3.6 VDO cockpit international, dia. 80 mm / dia. 100 mm
(Electronic Speedometer)

- Floodlight -

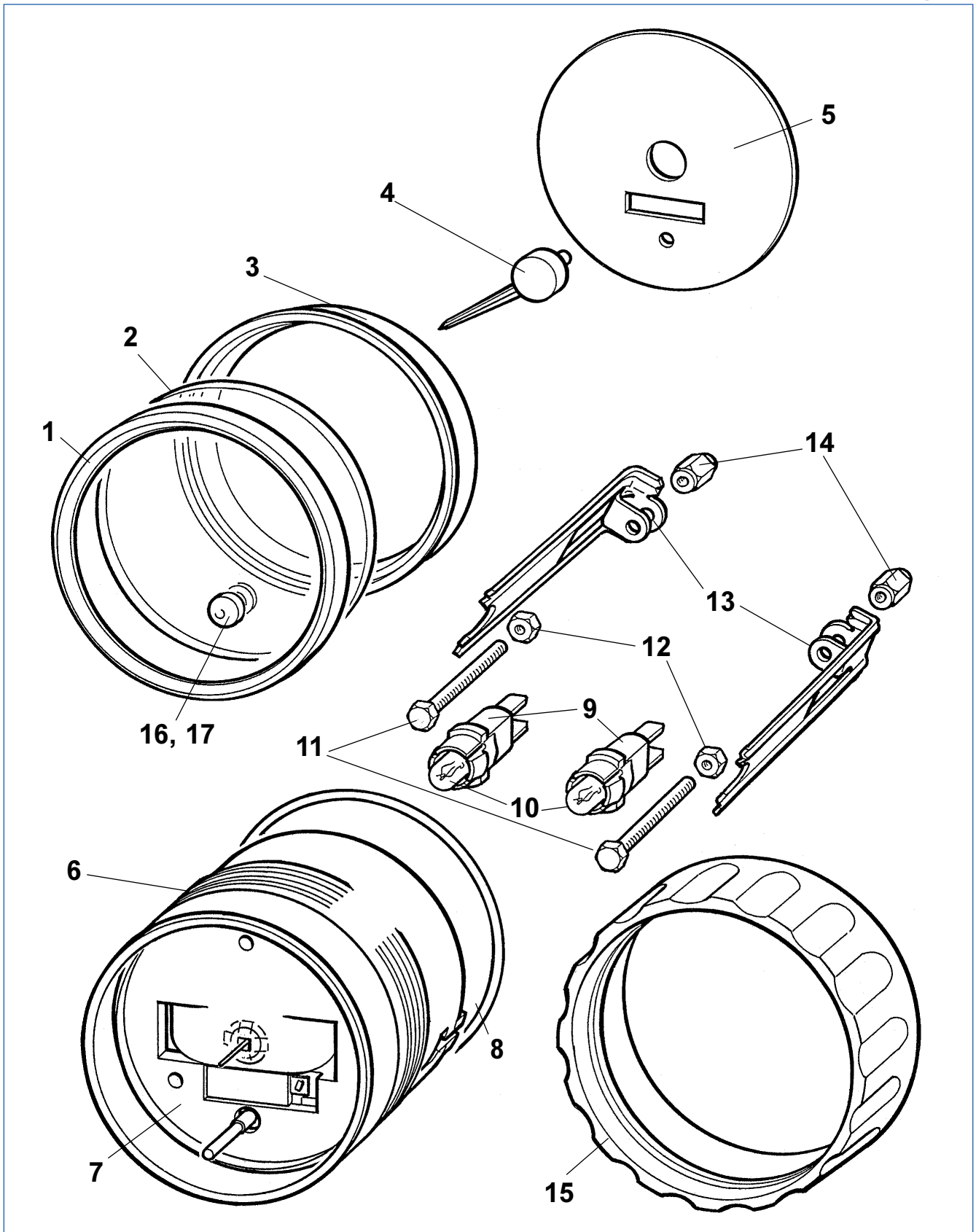

Technical Product Manual

VDO cockpit vision VDO cockpit international

17. Final Assembly

17.3 Modules, Parts

17.3.6 VDO cockpit international, dia. 80 mm / dia. 100 mm (Electronic Speedometer)

-Floodlight -

Pos.	Designation	Packaging unit	Part No.
1	Bezel black, flat dia. 80 mm	100	999-105-009
	Bezel black, flat dia. 100 mm	100	999-105-011
	Bezel black, triangled dia. 80 mm	100	999-105-005
	Bezel chrome, triangled dia. 80 mm	100	999-105-001
	Bezel black, triangled dia. 100 mm	100	999-105-007
	Bezel chrome, triangled dia. 100 mm	100	999-105-003
2	Lens (for reset shaft) clear dia. 80 mm	100	999-055-009
	Lens (for reset shaft) clear dia. 100 mm	100	999-055-011
	Lens (for reset shaft) nonreflective dia. 80 mm	100	999-055-013
	Lens (for reset shaft) nonreflective dia. 100 mm	100	999-055-015
3	Deflector dia. 80 mm	100	999-085-001
	Deflector dia. 100 mm	100	999-085-003
4	Pointer (SM) red dia. 80 mm	100	88-488-122-5185
	Pointer (SM) red dia. 100 mm	100	88-488-124-5185
5	Dial 0-60 km/h dia. 80 mm	100	999-045-001
	Dial 0-120 km/h dia. 80 mm	100	999-045-002
	Dial 0-200 km/h dia. 80 mm	100	999-045-003
	Dial 0-60 km/h dia. 100 mm	100	999-045-006
	Dial 0-120 km/h dia. 100 mm	100	999-045-007
6	Module (speedo SM) 12-24 V dia. 80 mm	10	888-085-001C
	12-24 V dia. 100 mm	10	888-105-001C
7	Light conductor dia. 80 mm	100	999-095-004
	Light conductor dia. 100 mm	100	999-095-005
8	Sealing ring dia. 80 mm	100	999-115-001
	Sealing ring dia. 100 mm	100	999-115-003
9	Lamp holder	100	999-067-001
10	Light bulb 12 V, 2W	100	999 065 001
	Light bulb 24 V, 2W	100	999 065 002
11	Hex screw	100	999-125-006
12	Hex nut	100	4-077-003-1161
13	Bracket	100	999-125-004
14	Nut	100	999-127-001
15	Clamp ring dia. 80 mm	100	999-071-001
	Clamp ring dia. 100 mm	100	999-071-003
16	Rubber cap	100	999-115-005
17	Bushing	100	999-115-010

Technical Product Manual

VDO cockpit vision VDO cockpit international

17. Final Assembly

17.3 Modules, Parts

17.3.7 VDO cockpit international, dia. 80 mm / dia. 100 mm
(Electronic Tachometer With Operating Hours Counter)

- Floodlight -

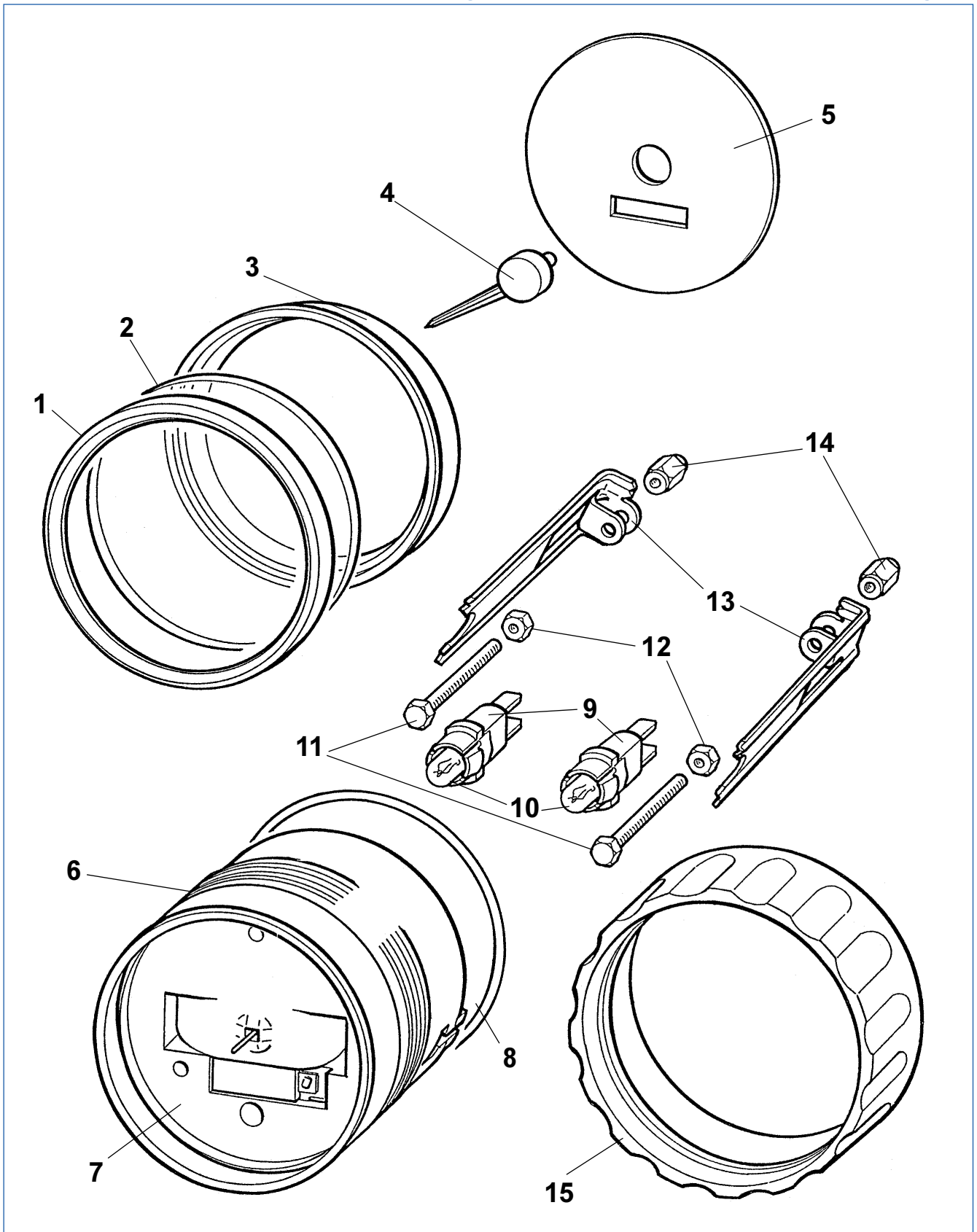

Technical Product Manual

VDO cockpit vision VDO cockpit international

17. Final Assembly

17.3 Modules, Parts

17.3.7 VDO cockpit international, dia. 80 mm / dia. 100 mm (Electronic Tachometer With Operating Hours Counter)

- Floodlight -

Pos.	Designation	Packaging unit	Part No.
1	Bezel black, flat dia. 80 mm	100	999-105-009
	Bezel black, flat dia. 100 mm	100	999-105-011
	Bezel black, triangled dia. 80 mm	100	999-105-005
	Bezel chrome, triangled dia. 80 mm	100	999-105-001
	Bezel black, triangled dia. 100 mm	100	999-105-007
	Bezel chrome, triangled dia. 100 mm	100	999-105-003
2	Lens clear dia. 80 mm	100	999-055-001
	Lens clear dia. 100 mm	100	999-055-003
	Lens nonreflective dia. 80 mm	100	999-055-005
	Lens nonreflective dia. 100 mm	100	999-055-007
3	Deflector dia. Ø 80 mm	100	999-085-001
	Deflector dia. 100 mm	100	999-085-003
4	Pointer (SM) red dia. 80 mm	100	88-488-122-5185
	Pointer (SM) red dia. 100 mm	100	88-488-124-5185
5	Dial 3000 min ⁻¹ dia. 80 mm	100	999-045-026
	Dial 4000 min ⁻¹ dia. 80 mm	100	999-045-027
	Dial 3000 min ⁻¹ dia. 100 mm	100	999-045-030
6	Module (tacho + EHM SM) 12-24 V dia. 80 mm	10	888-085-009C
	12-24 V dia. 100 mm	10	888-105-009C
7	Light conductor dia. 80 mm	100	999-095-004
	Light conductor dia. 100 mm	100	999-095-005
8	Sealing ring dia. 80 mm	100	999-115-001
	Sealing ring dia. 100 mm	100	999-115-003
9	Lamp holder	100	999-067-001
10	Light bulb 12 V, 2 W	100	999-065-001
	Light bulb 24 V, 2 W	100	999-065-002
11	Hex screw	100	999-125-006
12	Hex nut	100	4-077-003-1161
13	Bracket	100	999-125-004
14	Nut	100	999-127-001
15	Clamp ring dia. 80 mm	100	999-071-001
	Clamp ring dia. 100 mm	100	999-071 003

Technical Product Manual

VDO cockpit vision VDO cockpit international

17. Final Assembly

17.4 Assembly Sequence

17.4.1 Instruments 100 mm dia. or 80 mm dia. with stepper motor (electronic speedometer, electronic tachometer with operating hours counter)

Figure:
example: electronic speedometer 100 mm dia.

1. A condition for assembling is an anti-static work area to avoid destruction of electronic components of the module by electrostatic discharges.

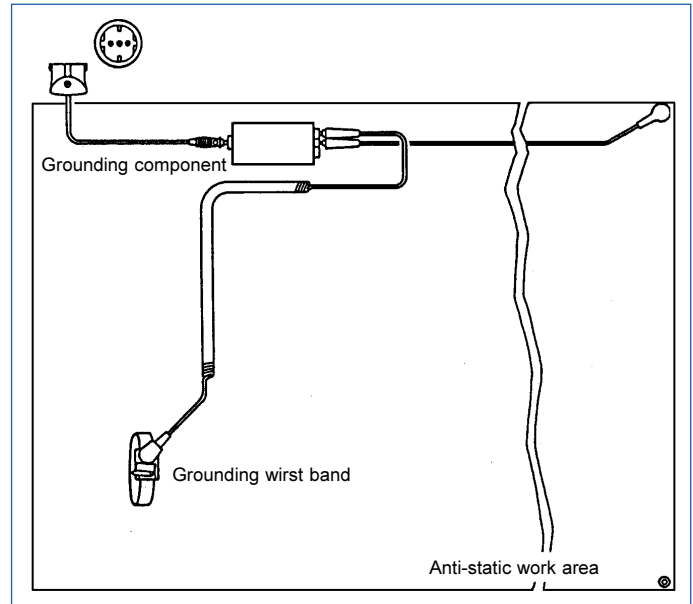

2. Remove the three screws with a Torx screwdriver.

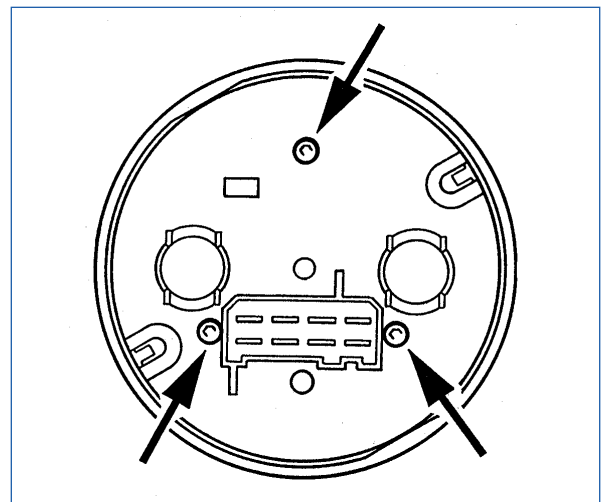

3. Carefully unclip the circuit board at the three points. Be careful with the flexible conductor!

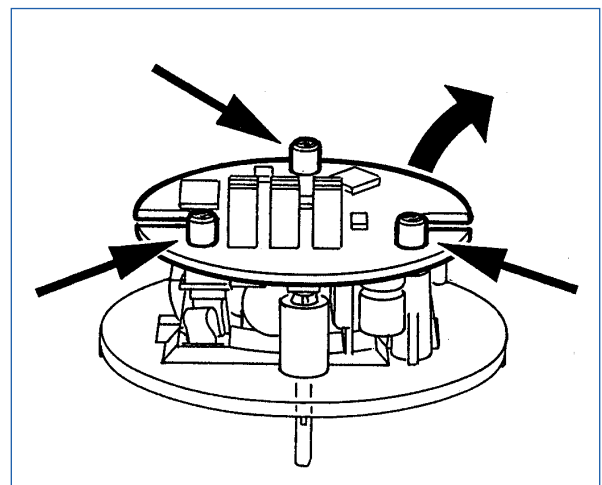

Technical Product Manual

VDO cockpit vision VDO cockpit international

17. Final Assembly

17.4 Assembly Sequence

17.4.1 Instruments 100 mm dia. or 80 mm dia. with stepper motor (electronic speedometer, electronic tachometer with operating hours counter)

Figure:
example: electronic speedometer 100 mm dia.

4. Unclip connector and remove flexible conductor.

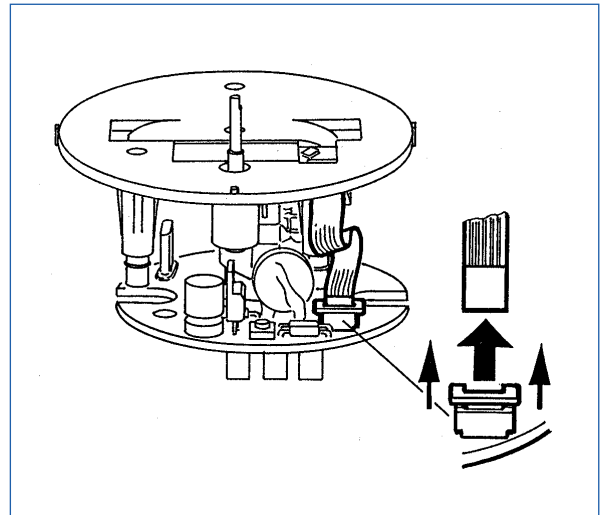

5. Remove protective film from display.

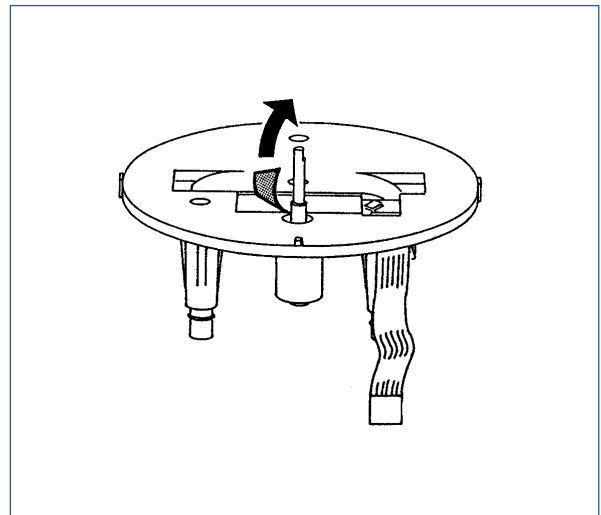

6. Remove protective film from adhesive dial surface.

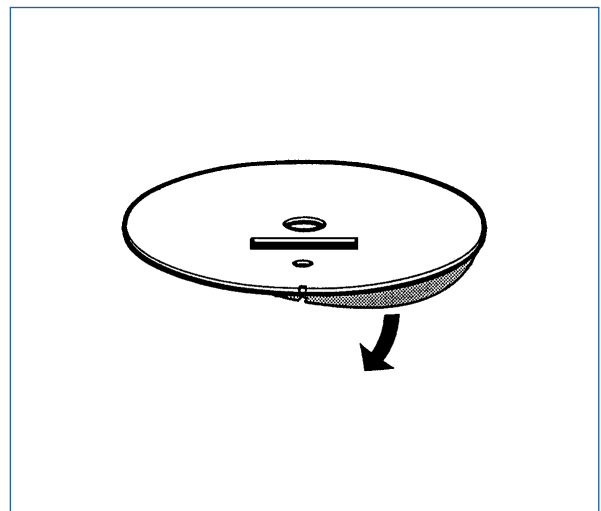

Technical Product Manual

VDO cockpit vision VDO cockpit international

17. Final Assembly

17.4 Assembly Sequence

17.4.1 Instruments 100 mm dia. or 80 mm dia. with stepper motor (electronic speedometer, electronic tachometer with operating hours counter)

Figure:
example: electronic speedometer 100 mm dia.

7. Adjust dial relative to cutout (6 o'clock position) and lightly press onto light conductor base.

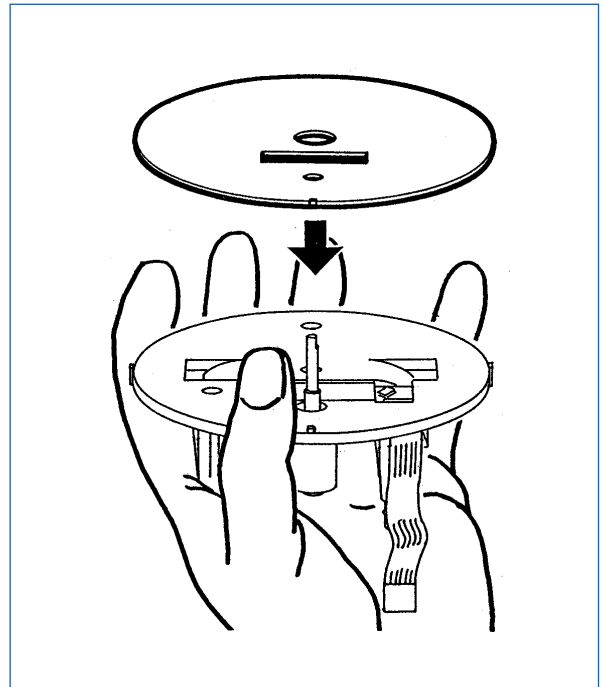

8. Insert light conductor with dial into fixture.



Take care not to pinch the flexible conductor.

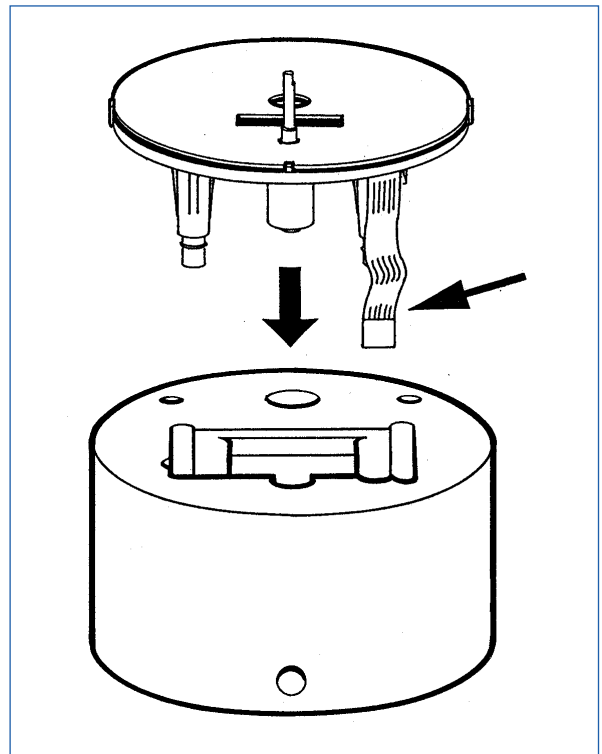

Technical Product Manual

VDO cockpit vision VDO cockpit international

17. Final Assembly

17.4 Assembly Sequence

17.4.1 Instruments 100 mm dia. or 80 mm dia. with stepper motor (electronic speedometer, electronic tachometer with operating hours counter)

Figure:

example: electronic speedometer 100 mm dia.

9. Position die.

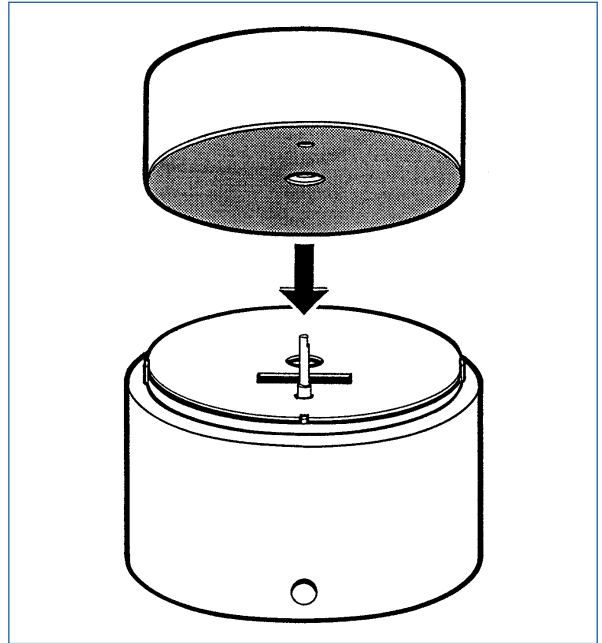

10. Insert dial with dial press.

Instrument 100 mm dia.: 1.7 t
Instrument 80 mm dia.: 0.9 t

Duration of pressure application: 2 seconds

Readjust the press if the actual values (pressure) greatly deviate from the above value specifications.

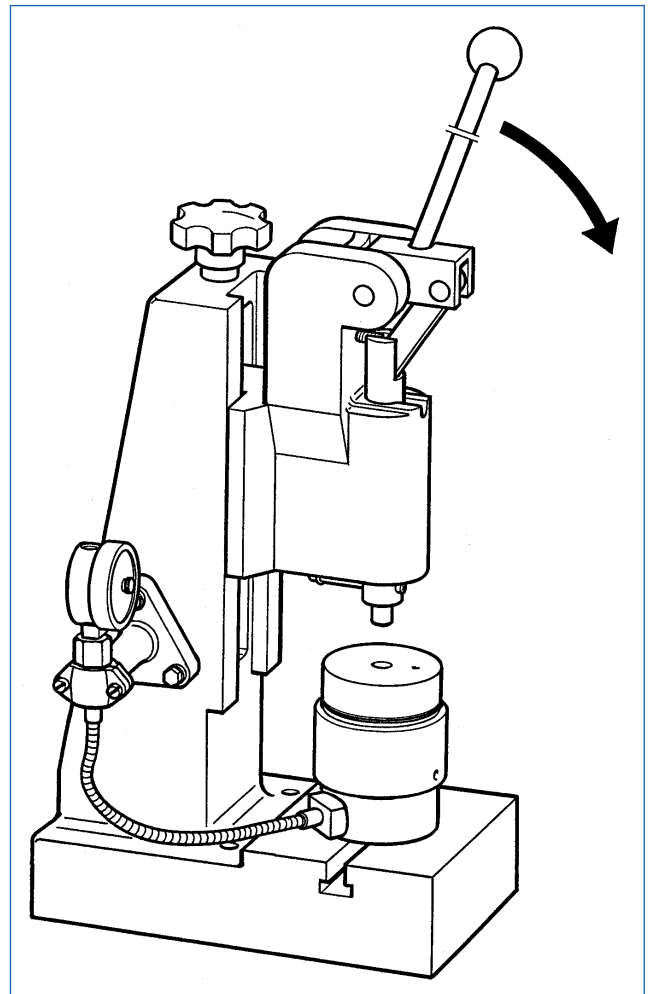

Technical Product Manual

VDO cockpit vision VDO cockpit international

17. Final Assembly

17.4 Assembly Sequence

17.4.1 Instruments 100 mm dia. or 80 mm dia. with stepper motor (electronic speedometer, electronic tachometer with operating hours counter)

Figure:

example: electronic speedometer 100 mm dia.

11. Insert flexible conductor into connector and clip in.

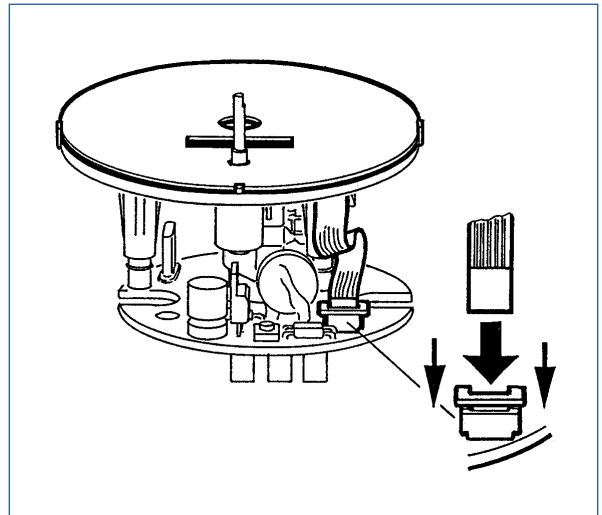

12. Clip circuit board to light conductor. Check for 'clipping sound'.

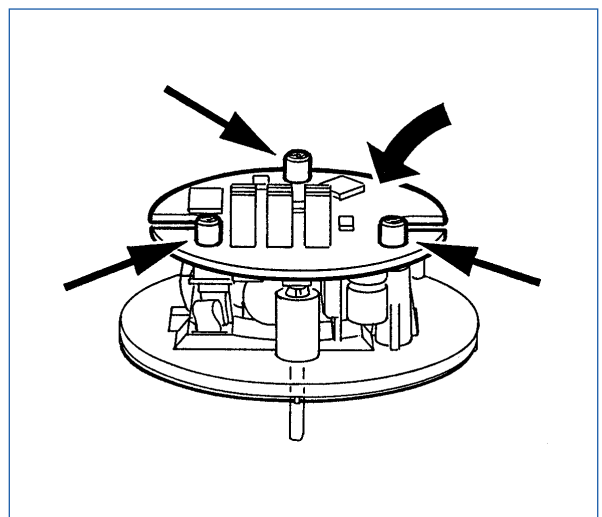

13. Insert complete unit into housing and fix with three screws.

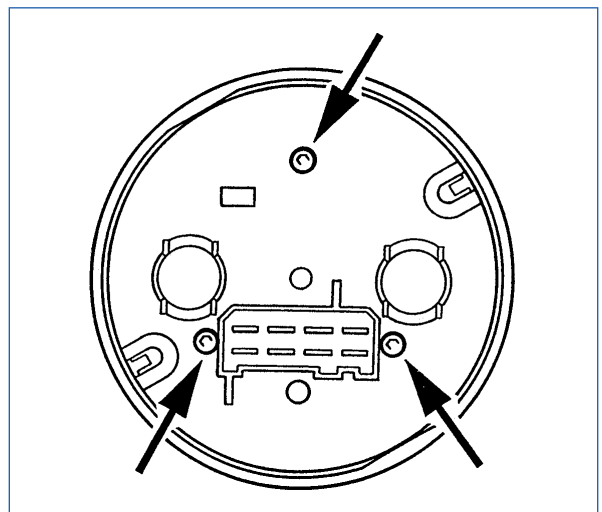

Technical Product Manual

VDO cockpit vision VDO cockpit international

17. Final Assembly

17.4 Assembly Sequence

17.4.1 Instruments 100 mm dia. or 80 mm dia. with stepper motor (electronic speedometer, electronic tachometer with operating hours counter)

Figure:
example: electronic speedometer 100 mm dia.

14. Connect programming cable to module and program (see software description).

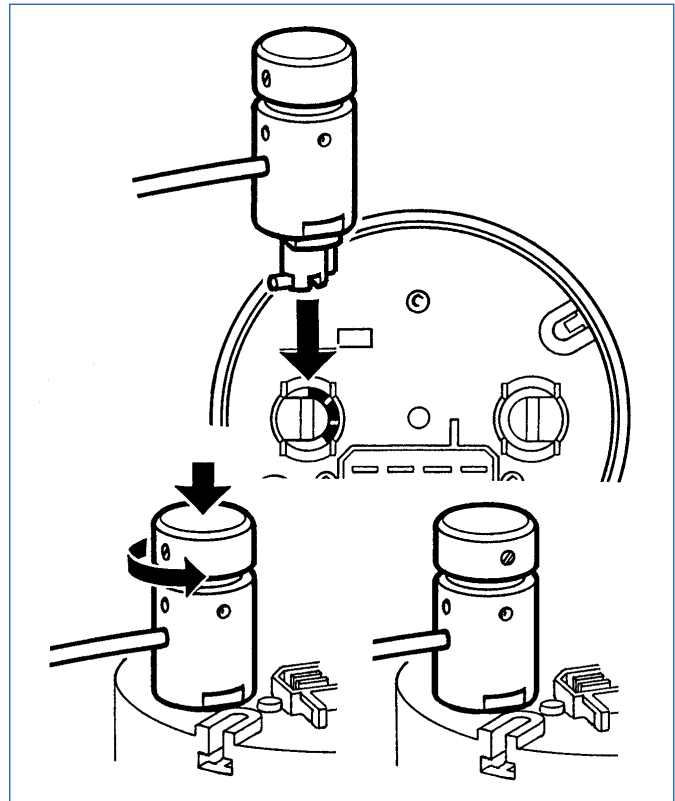

15. Place programmed module on powered fixture.

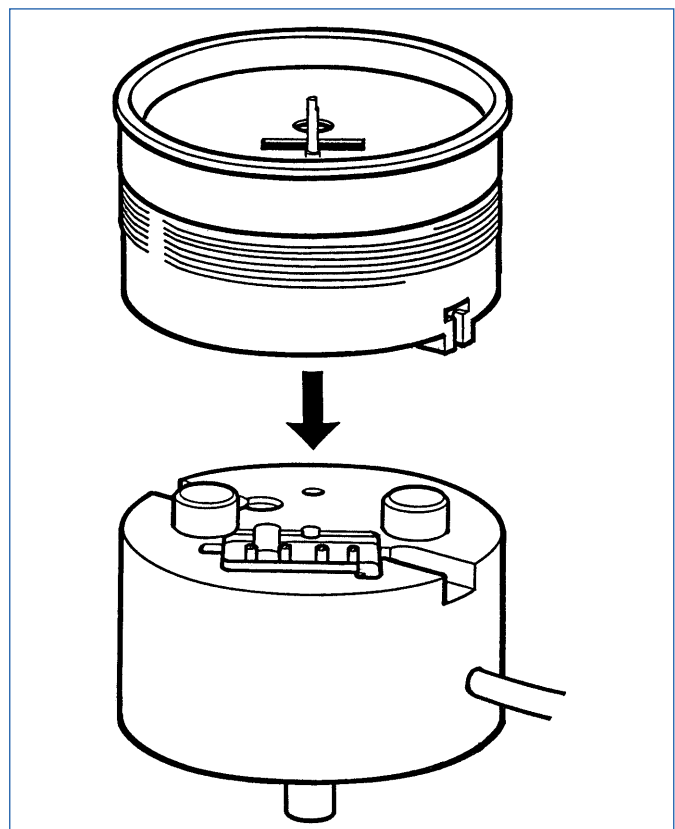

Technical Product Manual

VDO cockpit vision VDO cockpit international

17. Final Assembly

17.4 Assembly Sequence

17.4.1 Instruments 100 mm dia. or 80 mm dia. with stepper motor (electronic speedometer, electronic tachometer with operating hours counter)

Figure:
example: electronic speedometer 100 mm dia.

16. Lightly push pointer on to the pointer shaft and adjust to zero position.

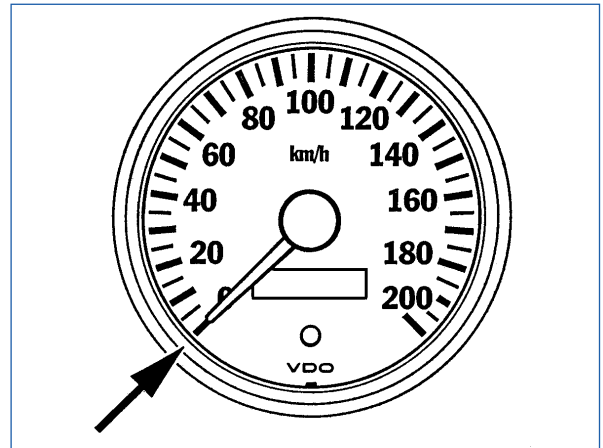

17. Using the pointer distance feeler gauge (0.5 mm) and the universal die, press pointer on with combined or universal press.

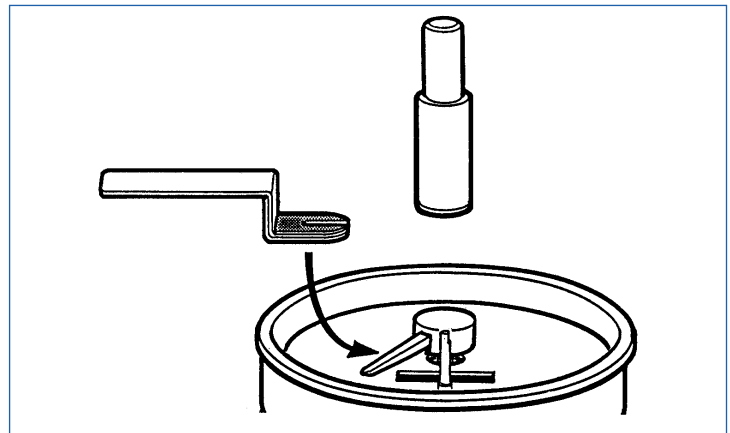

Do not remove the inserted pointer !

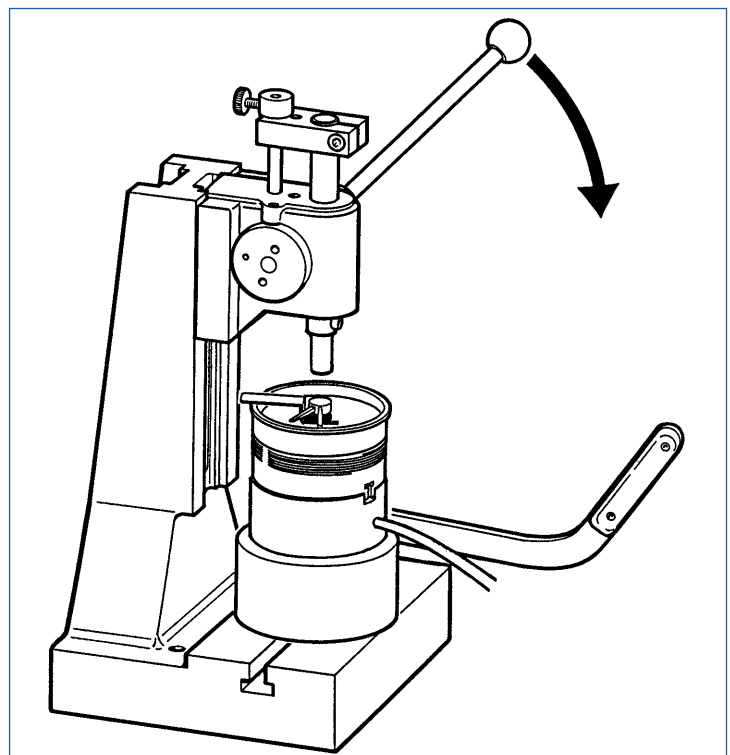

Technical Product Manual

VDO cockpit vision VDO cockpit international

17. Final Assembly

17.4 Assembly Sequence

17.4.1 Instruments 100 mm dia. or 80 mm dia. with stepper motor (electronic speedometer, electronic tachometer with operating hours counter)

Figure:

example: electronic speedometer 100 mm dia.

18. Insert deflector and lens (non-reflecting surface outwards).

Install bezel.

For the electronic speedometer insert the rubber cap (A) into the lens first, then bushing (B).

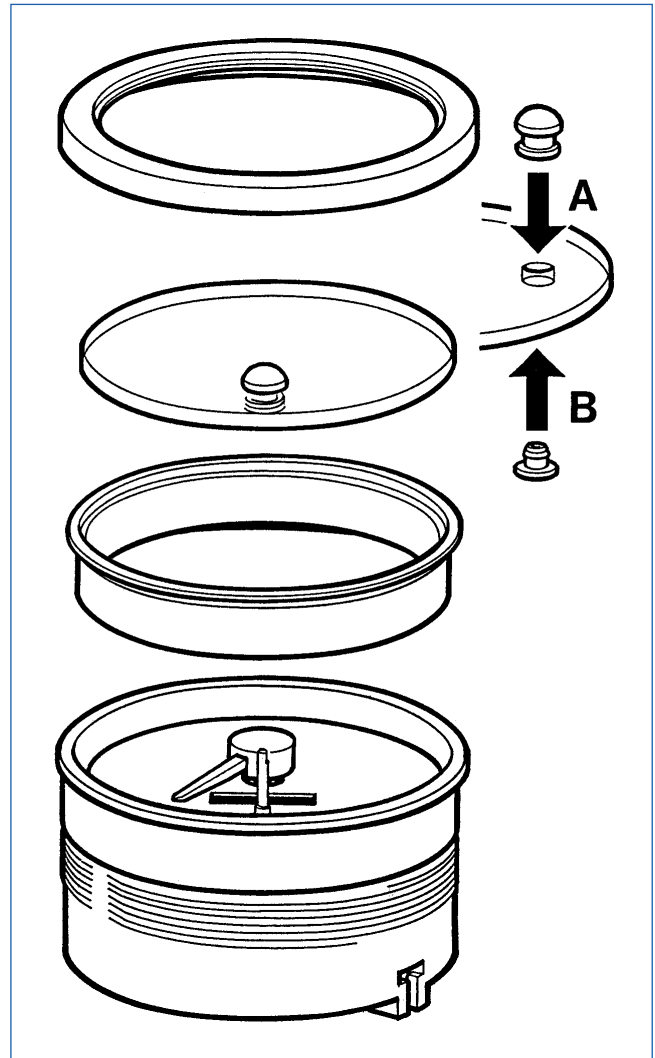

Technical Product Manual

VDO cockpit vision VDO cockpit international

17. Final Assembly

17.4 Assembly Sequence

17.4.1 Instruments 100 mm dia. or 80 mm dia. with stepper motor (electronic speedometer, electronic tachometer with operating hours counter)

Figure:

example: electronic speedometer 100 mm dia.

19. Place instrument on closing support and on the rotating fixture (or corresponding tool on other closing tool), correctly place the pressure foot and the centering piece into the correct position.

20. Use the universal press or an adequate rolling equipment to close the instrument.

In the case of the universal press guide the chasing lever so that the chasing wheel is parallel to the housing.

21. Check the indicating function of the instrument according to testing instructions in chapter 2 or chapter 4.

22. Add clamp ring or fixation set and 12 V or 24 V lamp bulbs per customer specification.

23. Mark with the workshop stamp in the 6 o'clock position on the rear side of the instrument (workshop No., month, year).

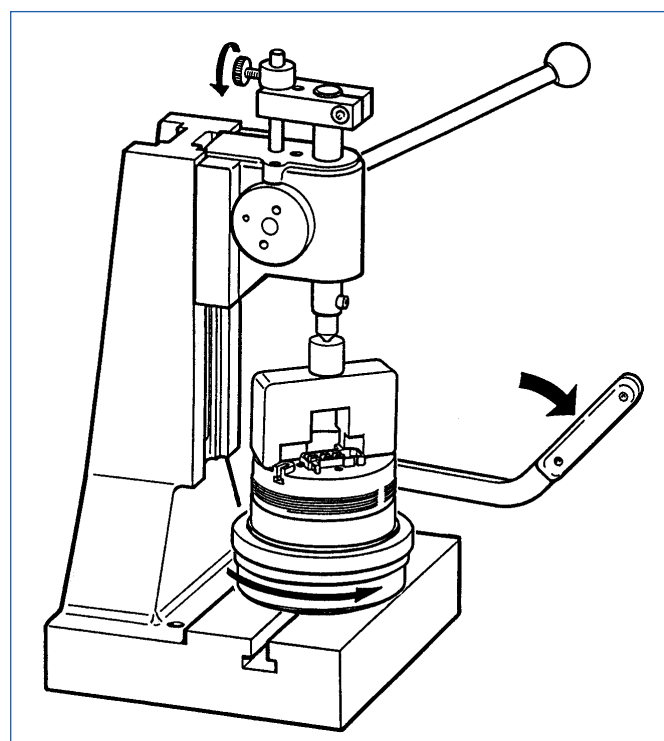
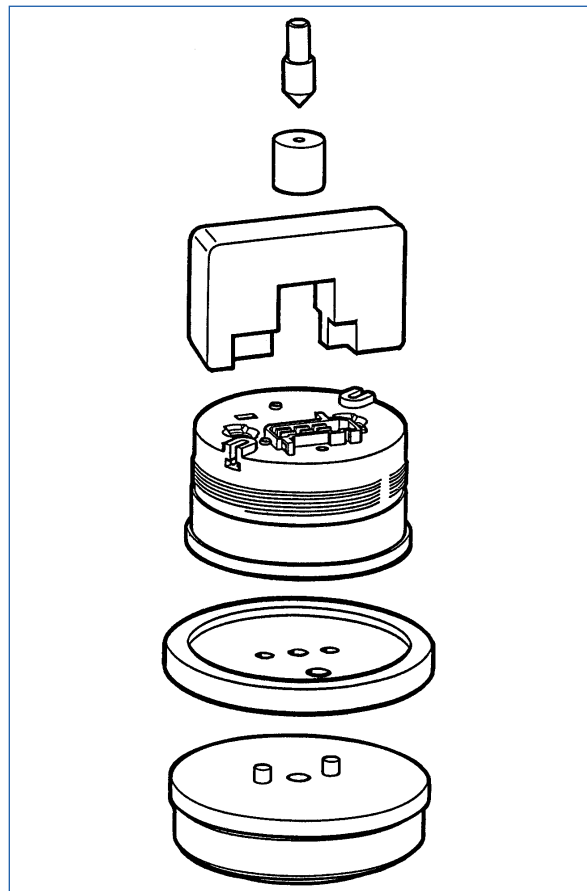

Technical Product Manual

VDO cockpit vision VDO cockpit international

17. Final Assembly

17.4 Assembly Sequence

17.4.2 Instruments 100 mm dia. or 80 mm dia. with Ke movement (electronic tachometer)

Figure: example: electronic tachometer 100 mm dia.

1. A condition for assembling is an anti-static work area to avoid destruction of electronic components of the module by electrostatic discharges.

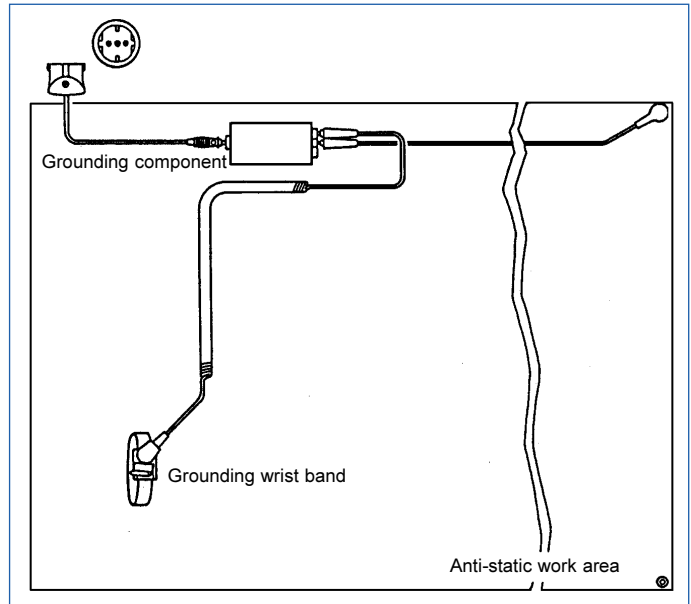

2. Remove the three screws with a Torx screwdriver.

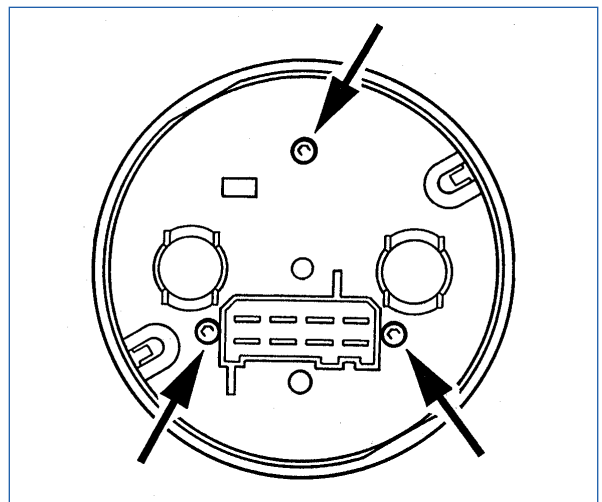

3. Carefully unclip the circuit board from the light conductor.

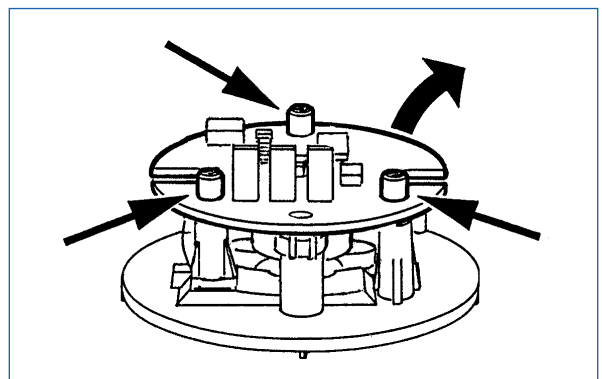

Technical Product Manual

VDO cockpit vision VDO cockpit international

17. Final Assembly

17.4 Assembly Sequence

17.4.2 Instruments 100 mm dia. or 80 mm dia. with Ke movement (electronic tachometer)

Figure: example: electronic tachometer 100 mm dia.

4. Remove protective film from display.
5. Adjust dial relative to cutout (6 o'clock position) and lightly press onto light conductor.
6. Insert light conductor with dial into fixture.

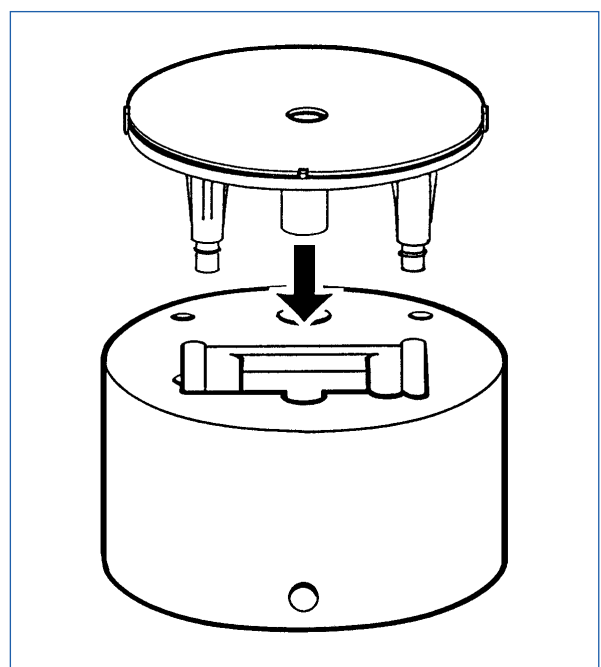
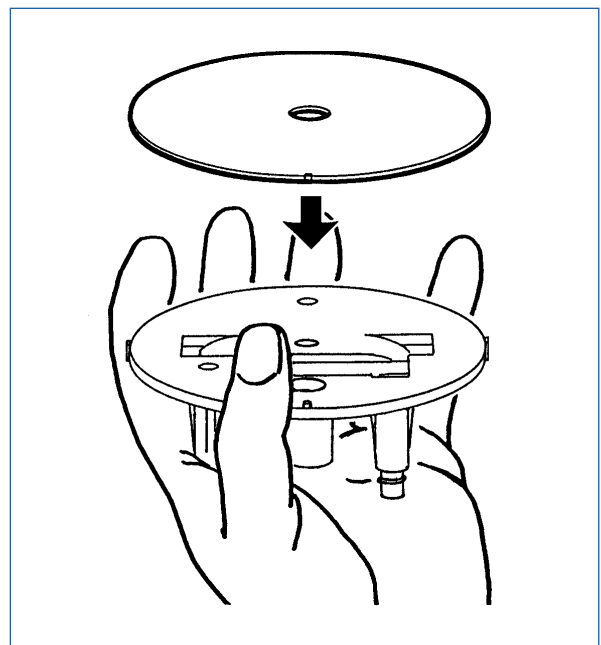
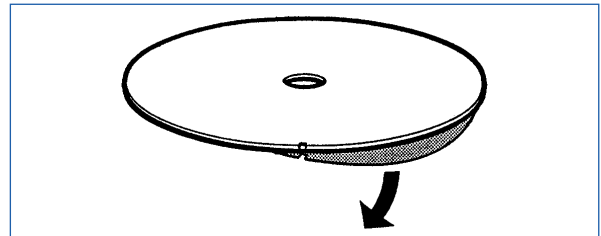

Technical Product Manual

VDO cockpit vision VDO cockpit international

17. Final Assembly

17.4 Assembly Sequence

17.4.2 Instruments 100 mm dia. or 80 mm dia. with Ke movement (electronic tachometer)

Figure: example: electronic tachometer 100 mm dia.

7. Position die.



8. Insert dial with dial press.

Instrument 100 mm dia.: 1.7 t
Instrument 80 mm dia.: 0.9 t

Duration of pressure application: 2 seconds

Readjust the press if the actual values (pressure) strongly deviate from the above value specifications.

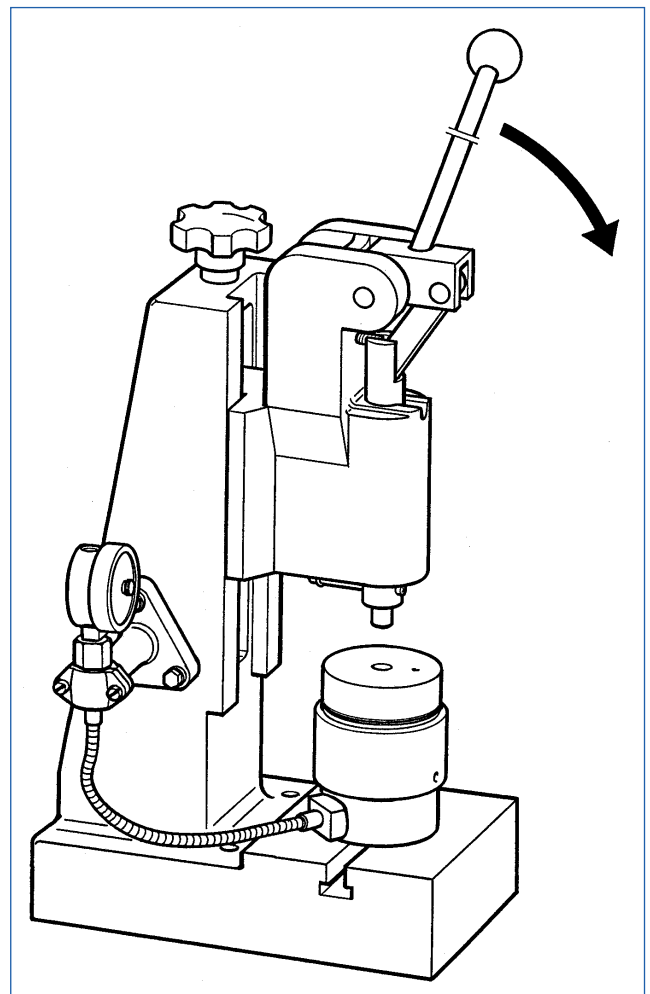

Technical Product Manual

VDO cockpit vision VDO cockpit international

17. Final Assembly

17.4 Assembly Sequence

17.4.2 Instruments 100 mm dia. or 80 mm dia. with Ke movement (electronic tachometer)

Figure: example: electronic tachometer 100 mm dia.

9. Clip circuit board to light conductor. Check for 'clipping sound'.

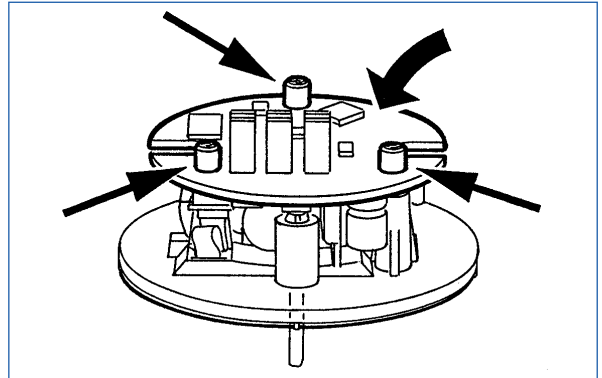

10. Insert complete unit into housing and fix with three screws.

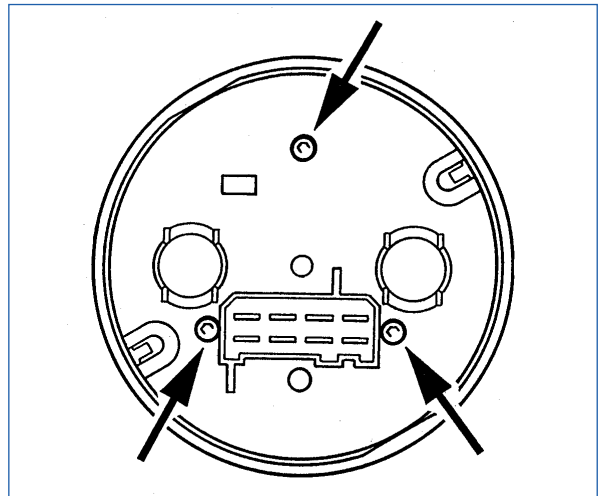

Technical Product Manual

VDO cockpit vision VDO cockpit international

17. Final Assembly

17.4 Assembly Sequence

17.4.2 Instruments 100 mm dia. or 80 mm dia. with Ke movement (electronic tachometer)

Figure: example: electronic tachometer 100 mm dia.

11. Place programmed module on powered fixture.

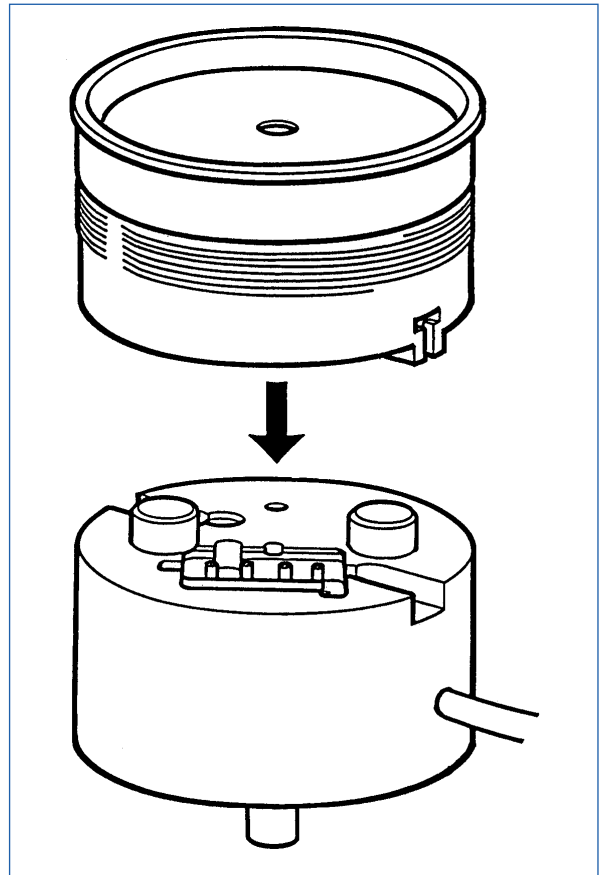

12. Lightly push pointer on pointer shaft and adjust to zero position.

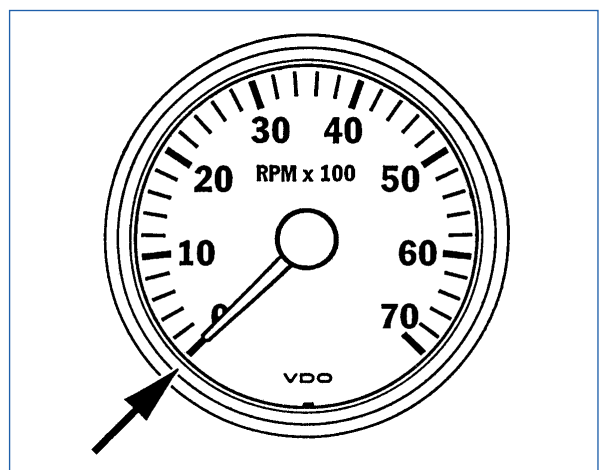

Technical Product Manual

VDO cockpit vision VDO cockpit international

17. Final Assembly

17.4 Assembly Sequence

17.4.2 Instruments 100 mm dia. or 80 mm dia. with Ke movement (electronic tachometer)

Figure: example: electronic tachometer 100 mm dia.

13. Using the pointer distance feeler gauge (0.5 mm) and the universal die, press pointer on with combined or universal press.

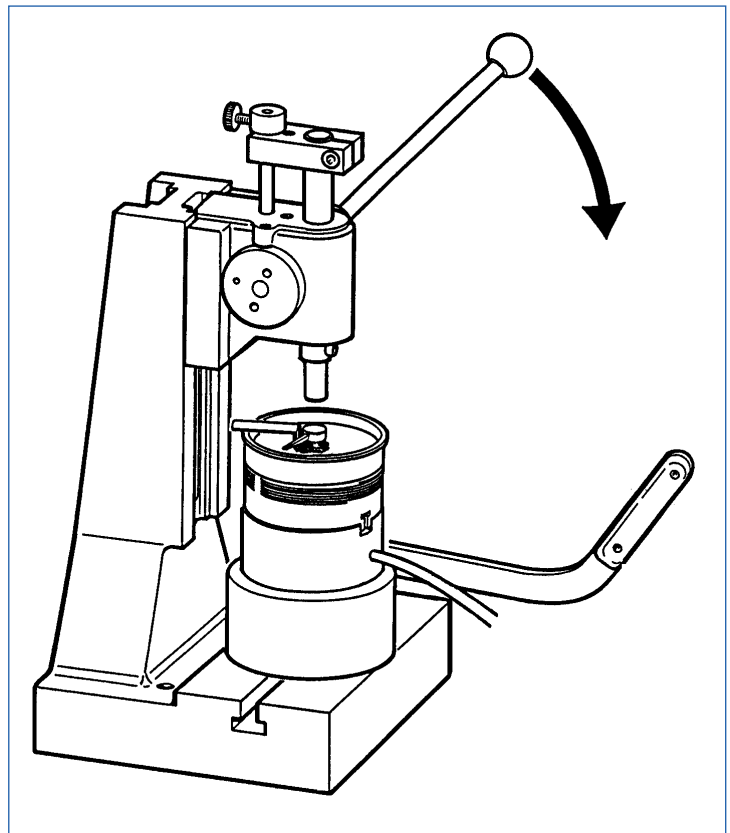
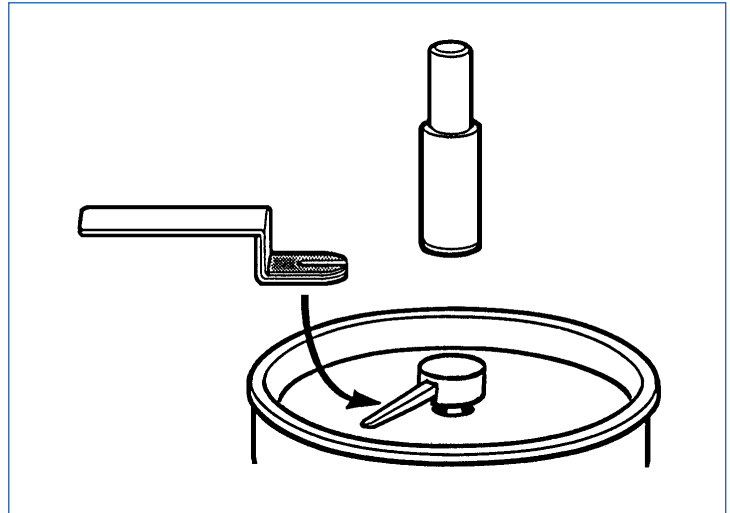

Technical Product Manual

VDO cockpit vision VDO cockpit international

17. Final Assembly

17.4 Assembly Sequence

17.4.2 Instruments 100 mm dia. or 80 mm dia. with Ke movement (electronic tachometer)

Figure: example: electronic tachometer 100 mm dia.

14. Insert deflector and lens (non-reflecting surface outwards).

Install bezel.

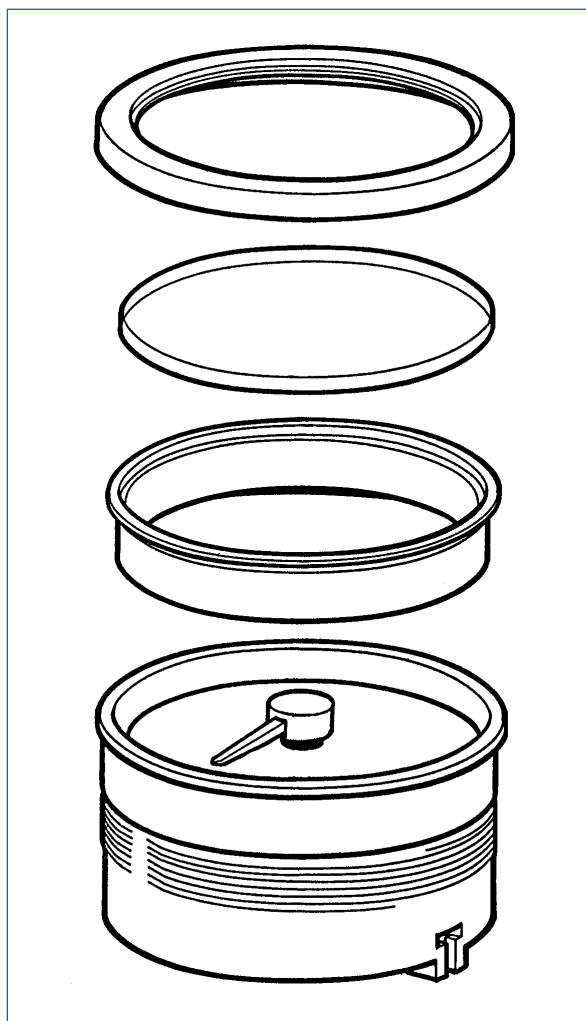

Technical Product Manual

VDO cockpit vision VDO cockpit international

17. Final Assembly

17.4 Assembly Sequence

17.4.2 Instruments 100 mm dia. or 80 mm dia. with Ke movement (electronic tachometer)

Figure: example: electronic tachometer 100 mm dia.

15. Place instrument on closing support and on the rotating fixture (or corresponding tool on other closing tool), correctly place the pressure foot and the centering piece in the correct position.

16. Use the universal press or an adequate rolling equipment to close the instrument.

In the case of the universal press guide the chasing lever so that the chasing wheel is parallel to the housing.

17. Check the indicating function of the instrument according to testing instructions in chapter 3.

18. Add clamp ring or fixation set and 12 V or 24 V lamp bulbs per customer specification.

19. Mark with the workshop stamp in the 6 o'clock position on the rear side of the instrument (workshop No., month, year).

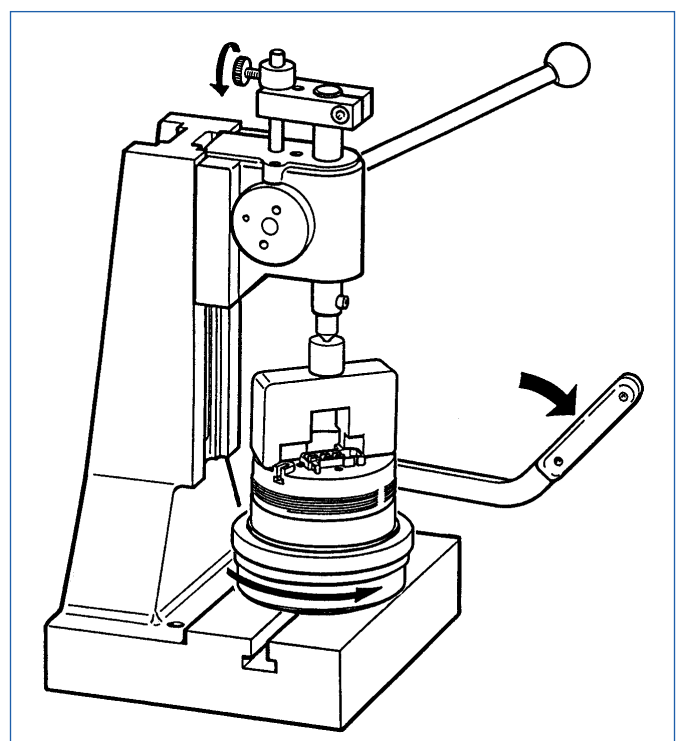
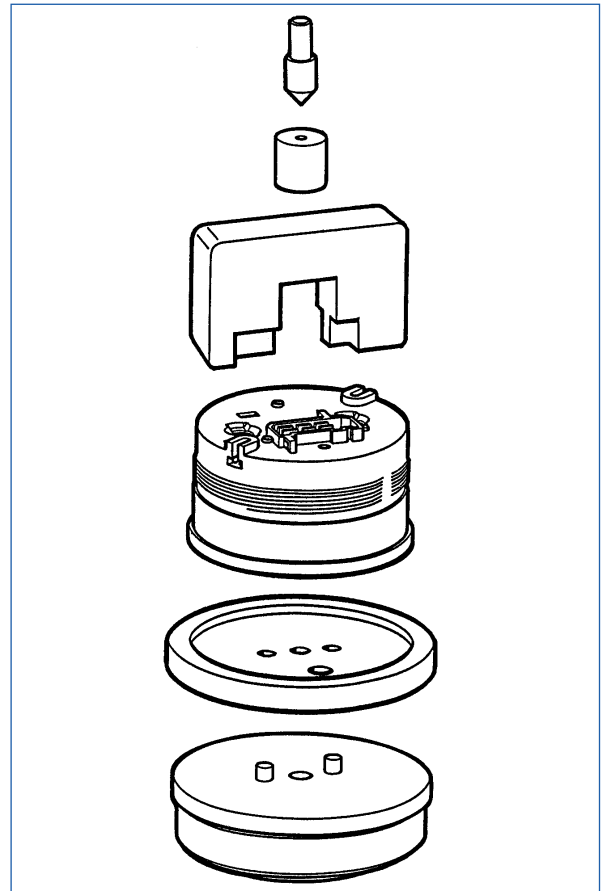

Technical Product Manual

VDO cockpit vision VDO cockpit international

17. Final Assembly

17.4 Assembly Sequence

17.4.3 Instruments 52 mm dia. VDO cockpit vision (pressure gauge, temperature gauge, fuel level gauge, voltmeter)

Figure: example: pressure gauge - backlight -

1. Insert stop pin into fixture.

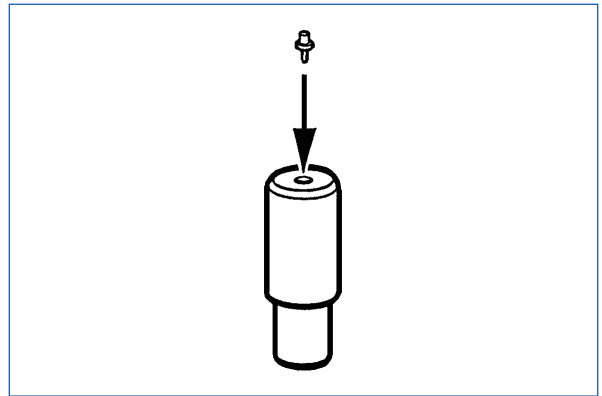

2. Place dial, print side facing downwards, and rivet the stop pin with riveting die, using the combined or universal press.

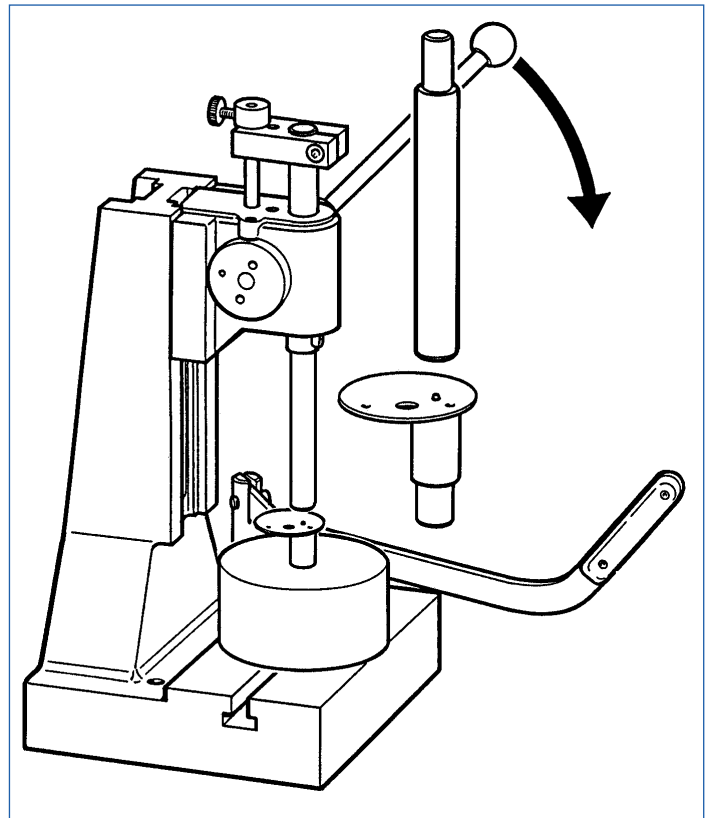

3. Remove protective film from adhesive dial surface, insert dial into light conductor so that the dial screw holes register.

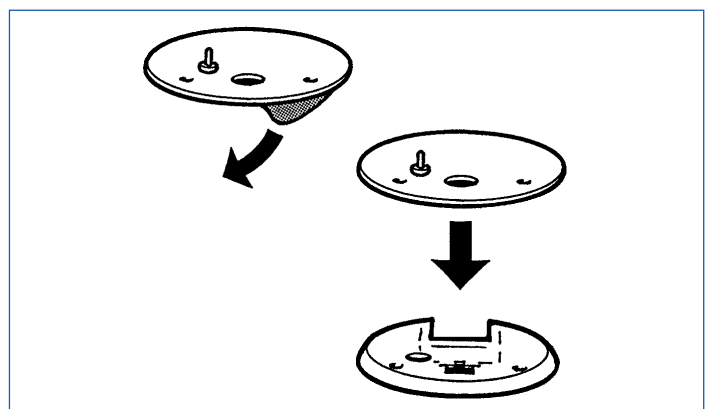

Technical Product Manual

VDO cockpit vision VDO cockpit international

17. Final Assembly

17.4 Assembly Sequence

17.4.3 Instruments 52 mm dia. VDO cockpit vision (pressure gauge, temperature gauge, fuel level gauge, voltmeter)

Figure: example: pressure gauge - backlight -

4. Insert light conductor with dial into fixture.

5. Install die.

6. Insert dial with the dial press.

0.55 t

Pressing duration: 2 seconds

Recalibrate the press if the actual values (pressure) strongly differ from the above specified values.

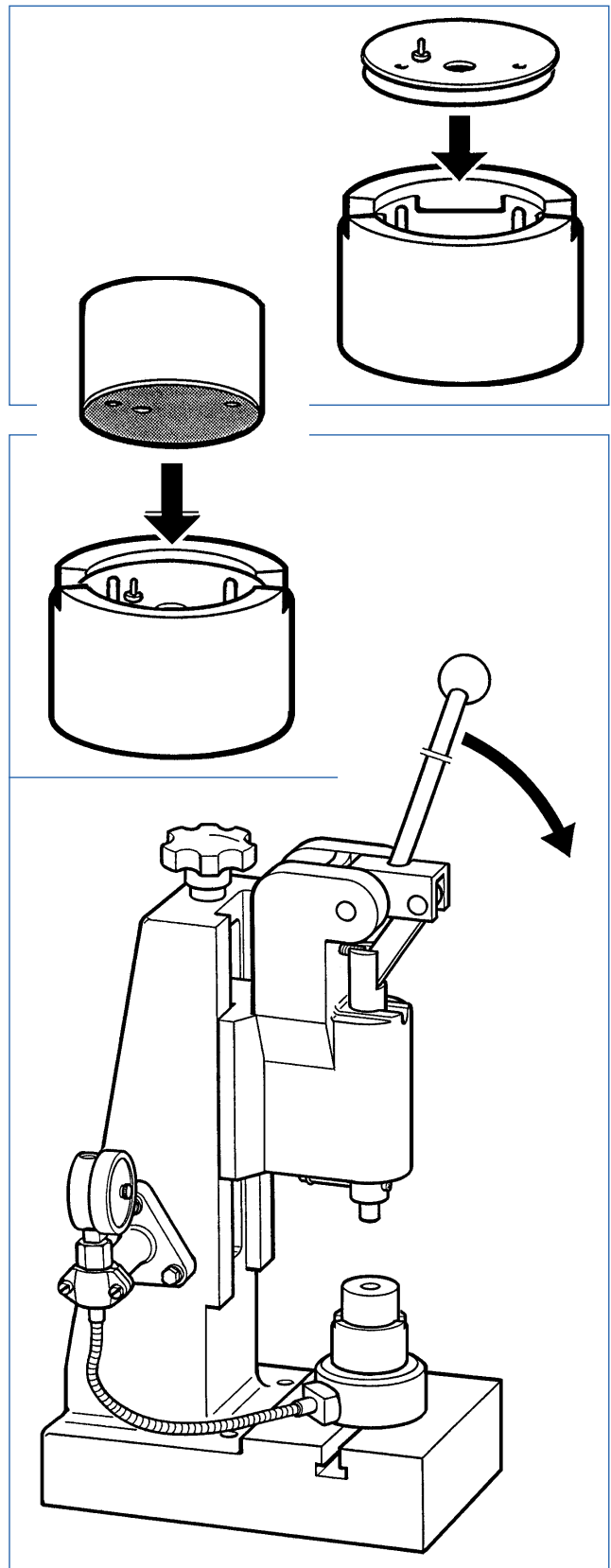

Technical Product Manual

VDO cockpit vision VDO cockpit international

17. Final Assembly

17.4 Assembly Sequence

17.4.3 Instruments 52 mm dia. VDO cockpit vision (pressure gauge, temperature gauge, fuel level gauge, voltmeter)

Figure: example: pressure gauge - backlight -

7. Insert completed unit into module and fix with two dial screws.

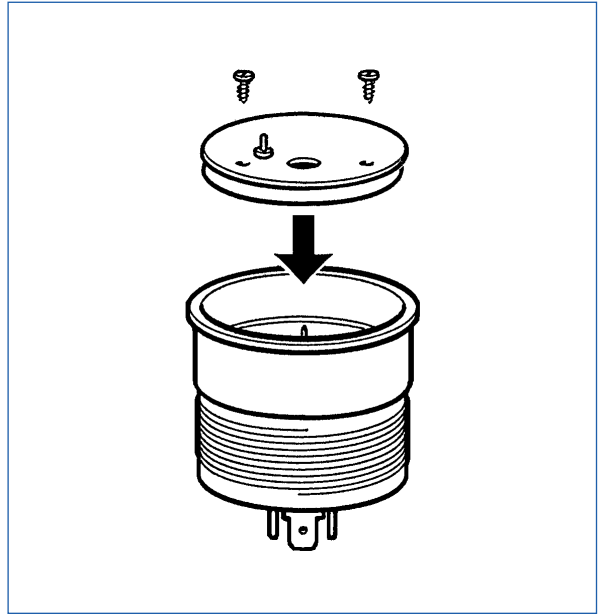

8. Place module into powered fixture.

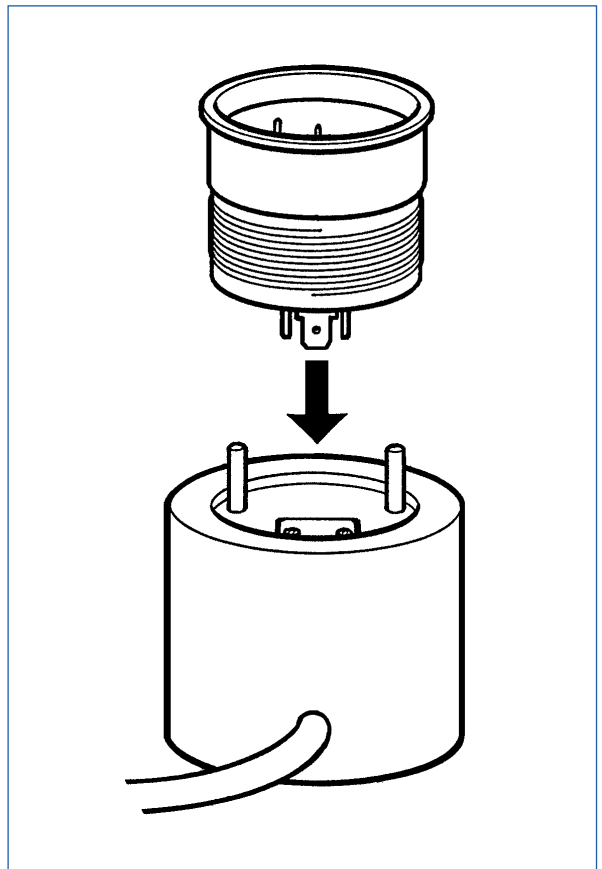

Technical Product Manual

VDO cockpit vision VDO cockpit international

17. Final Assembly

17.4 Assembly Sequence

17.4.3 Instruments 52 mm dia. VDO cockpit vision (pressure gauge, temperature gauge, fuel level gauge, voltmeter)

Figure: example: pressure gauge - backlight -

9. Connect powered fixture per connection diagram in the testing instructions of the corresponding movement (see chapters 6 to 10).

Take the pointer deflections from the table and set the corresponding resistance values.

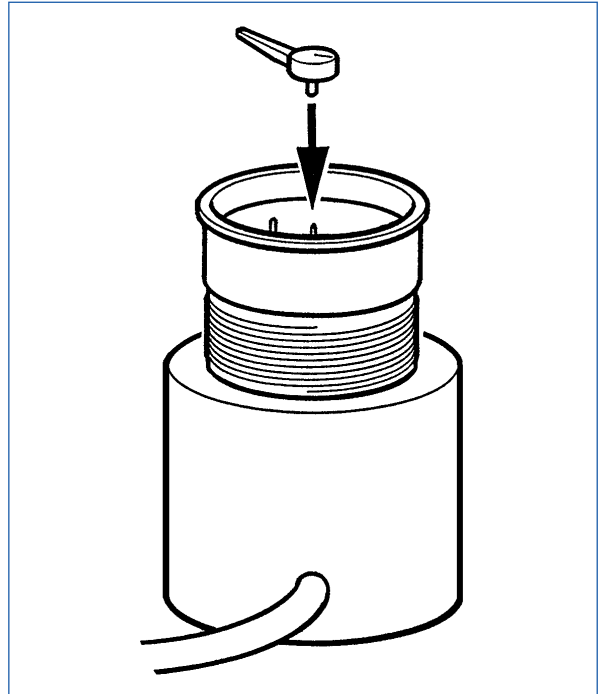

10. Lightly push pointer on to pointer shaft at the pointer position corresponding to the selected deflection.

Check pointer position (initial and end value of graduation) with the corresponding resistance value.

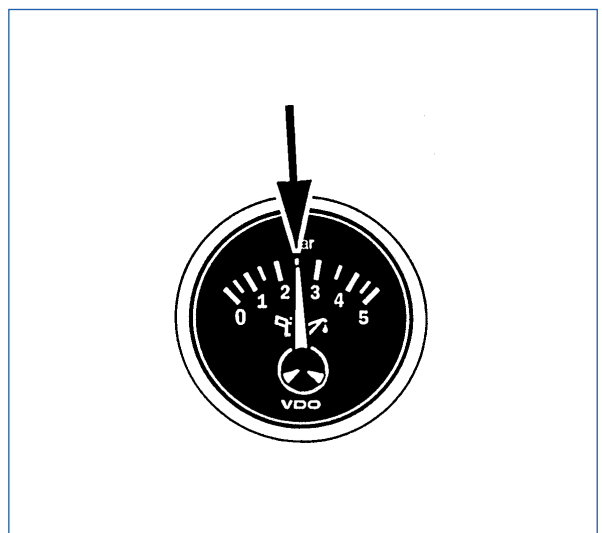

Technical Product Manual

VDO cockpit vision VDO cockpit international

17. Final Assembly

17.4 Assembly Sequence

17.4.3 Instruments 52 mm dia. VDO cockpit vision (pressure gauge, temperature gauge, fuel level gauge, voltmeter)

Figure: example: pressure gauge - backlight -

11. Use pointer spacing feeler gauge (0.3 mm) and universal die to push the pointer in place, using the combined or universal press.

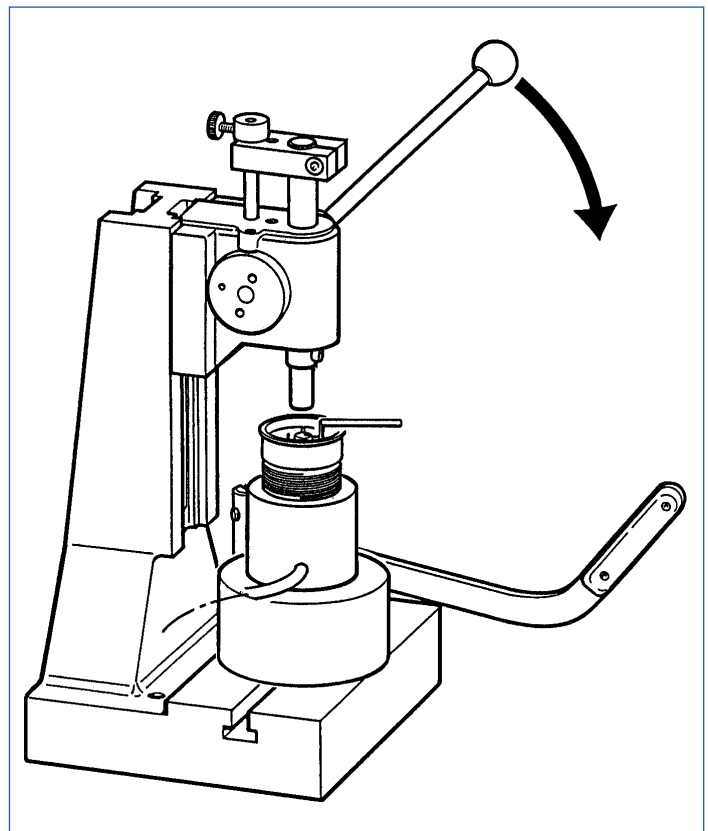
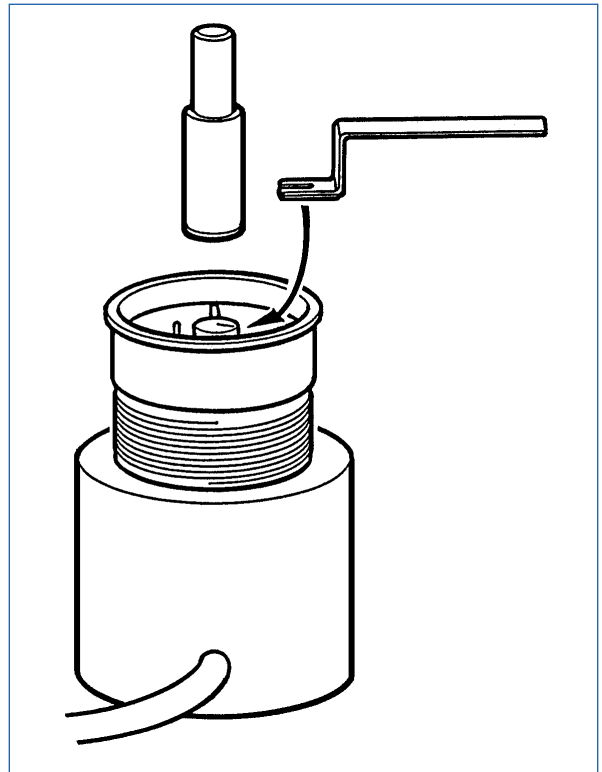

Technical Product Manual

VDO cockpit vision VDO cockpit international

17. Final Assembly

17.4 Assembly Sequence

17.4.3 Instruments 52 mm dia. VDO cockpit vision (pressure gauge, temperature gauge, fuel level gauge, voltmeter)

Figure: example: pressure gauge - backlight -

12. Insert deflector and lens (non-reflecting surface outwards).

Install bezel.

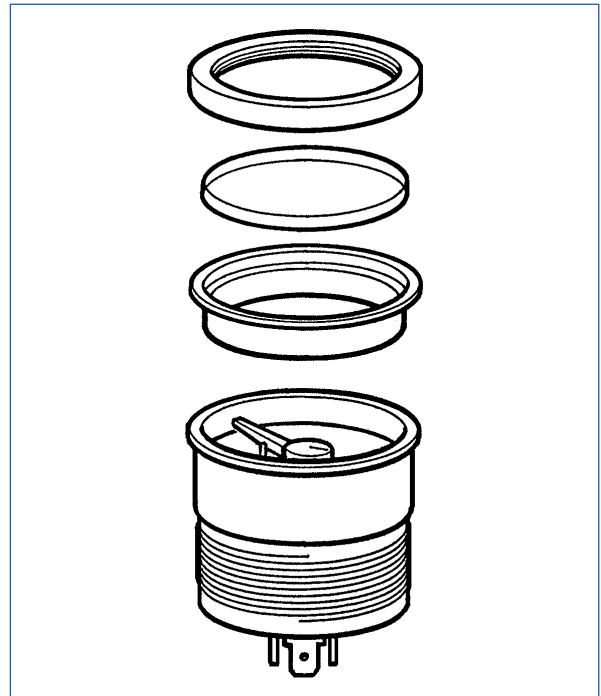

13. Place instrument on closing support and on the rotating fixture (or corresponding tool on other closing tool), correctly place the pressure foot and the centering piece into correct position.

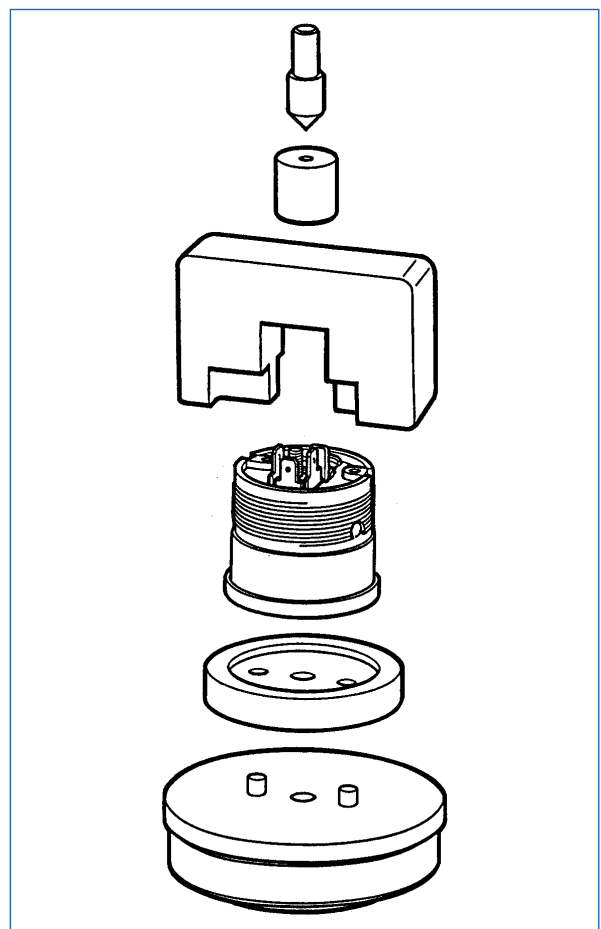

Technical Product Manual

VDO cockpit vision VDO cockpit international

17. Final Assembly

17.4 Assembly Sequence

17.4.3 Instruments 52 mm dia. VDO cockpit vision (pressure gauge, temperature gauge, fuel level gauge, voltmeter)

Figure: example: pressure gauge - backlight -

14. Use the universal press or an adequate rolling equipment to close the instrument.

In the case of the universal press guide the chasing lever so that the chasing wheel is parallel to the housing.

15. Check the indicating functions of the instrument according to the particular testing instructions in chapters 6 to 10.
16. Add clamp ring or fixation set and 12 V or 24 V lamp bulbs per customer specification.
17. Mark with the workshop stamp on the rear side of the instrument (workshop No., month, year).

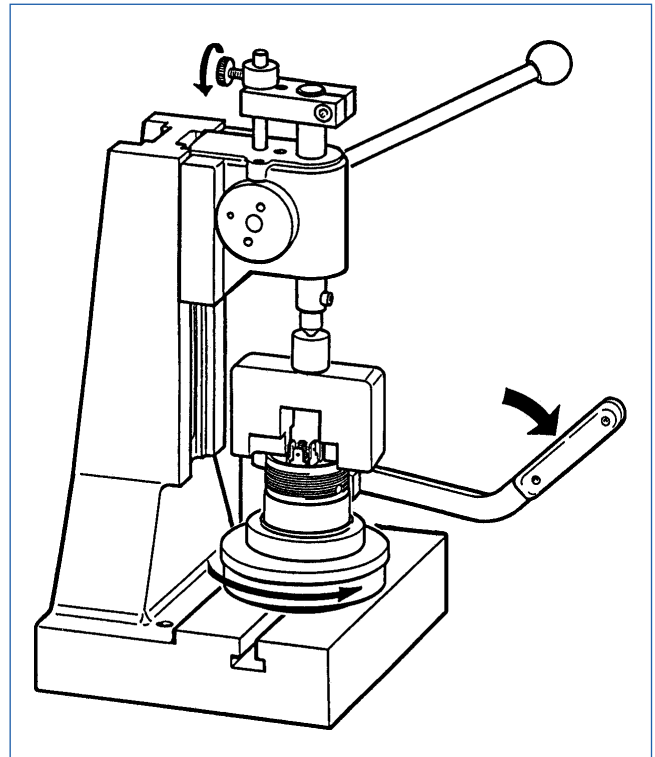

Technical Product Manual

VDO cockpit vision VDO cockpit international

17. Final Assembly

17.4 Assembly Sequence

17.4.4 Instruments 52 mm dia. VDO cockpit international (pressure gauge, temperature gauge, fuel level gauge, voltmeter)

Figure: example: pressure gauge - floodlight -

1. Insert stop pin fixture.

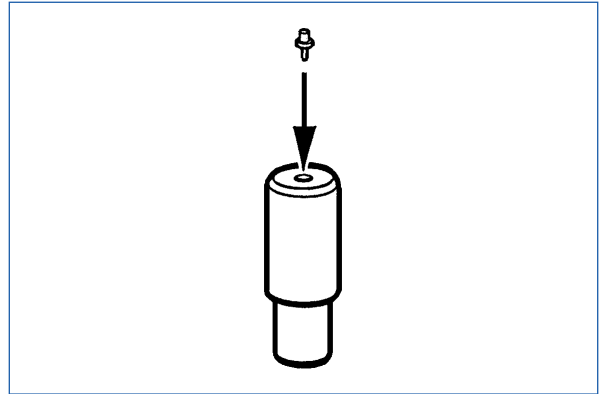

2. Place dial, print side facing downwards, and rivet the stop pin with riveting die, using the combined or universal press.

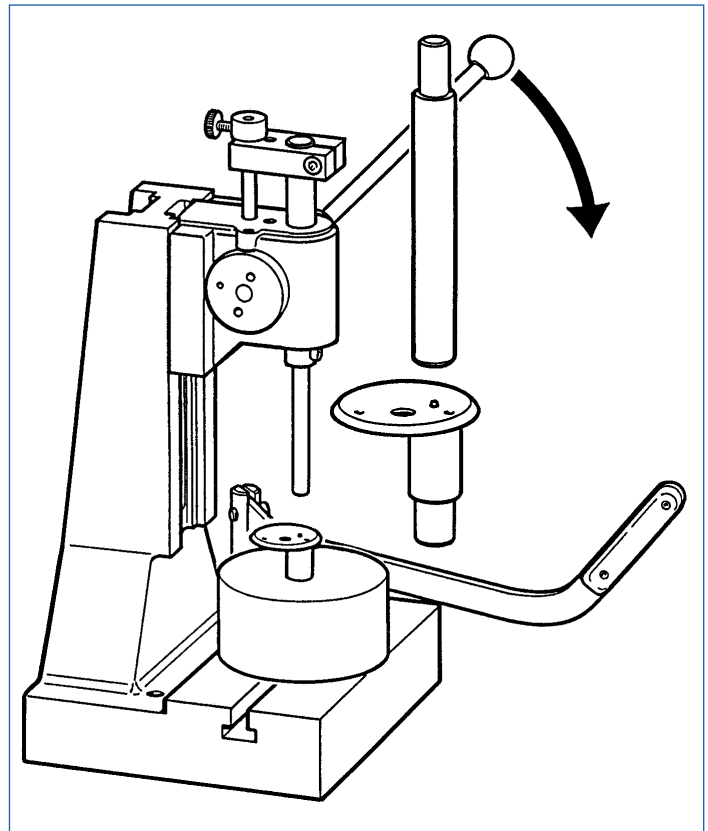

Technical Product Manual

VDO cockpit vision VDO cockpit international

17. Final Assembly

17.4 Assembly Sequence

17.4.4 Instruments 52 mm dia. VDO cockpit international (pressure gauge, temperature gauge, fuel level gauge, voltmeter)

Figure: example: pressure gauge - floodlight -

3. Insert dial into module and fix with two dial screws.

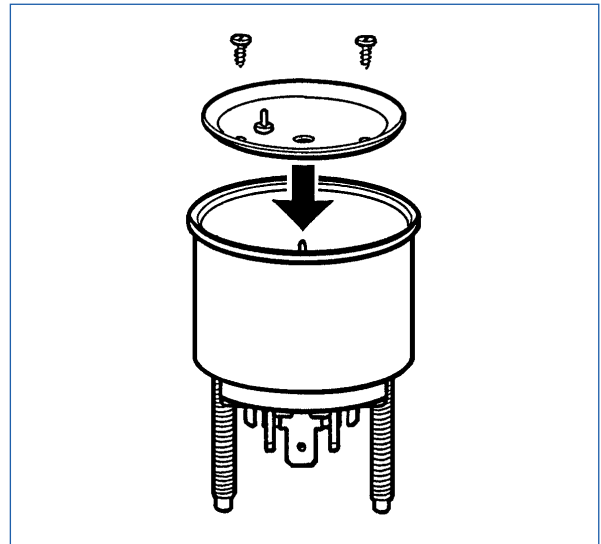

4. Place module into powered fixture.

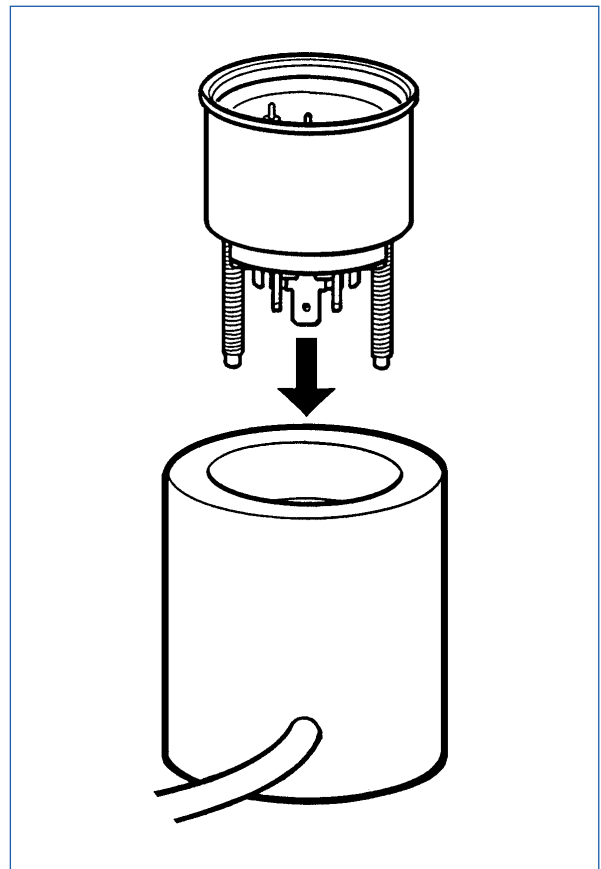

Technical Product Manual

VDO cockpit vision VDO cockpit international

17. Final Assembly

17.4 Assembly Sequence

17.4.4 Instruments 52 mm dia. VDO cockpit international (pressure gauge, temperature gauge, fuel level gauge, voltmeter)

Figure: example: pressure gauge - floodlight -

5. Connect powered fixture per connection diagram in the testing instructions of the corresponding movement (see chapters 6 to 10).

Take the pointer deflections from the table and set the corresponding resistance values.

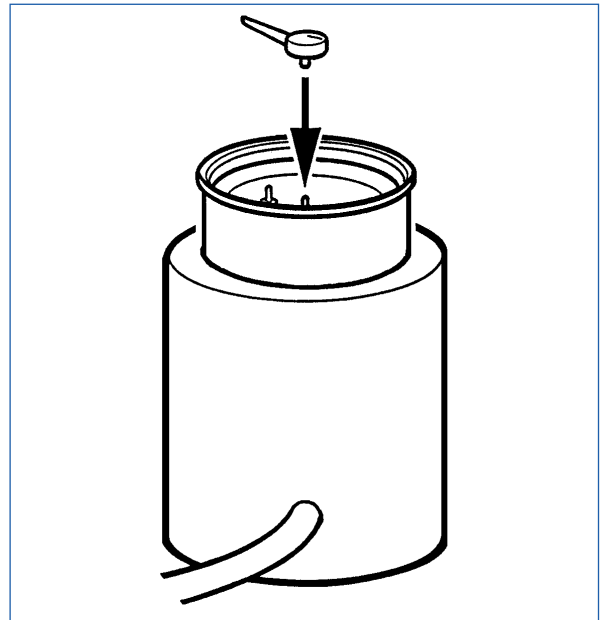

6. Lightly push pointer on pointer shaft at the pointer position corresponding to the selected deflection.

Check pointer position (initial and end value of graduation) with the corresponding resistance value.

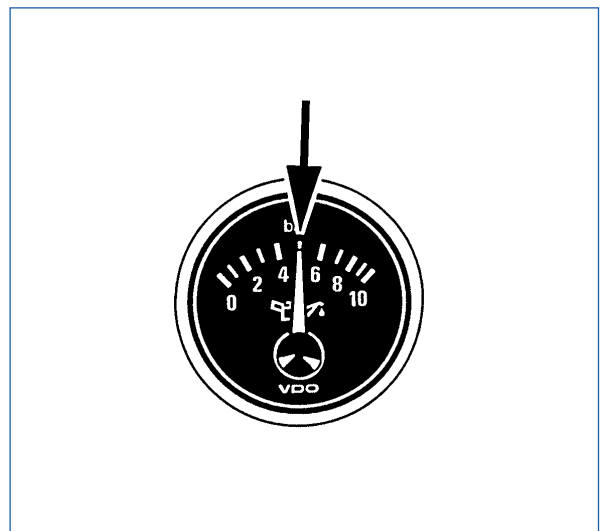

Technical Product Manual

VDO cockpit vision VDO cockpit international

17. Final Assembly

17.4 Assembly Sequence

17.4.4 Instruments 52 mm dia. VDO cockpit international (pressure gauge, temperature gauge, fuel level gauge, voltmeter)

Figure: example: pressure gauge - floodlight -

7. Use pointer spacing feeler gauge (3 mm) and universal die to push the pointer in place, using the combined or universal press.

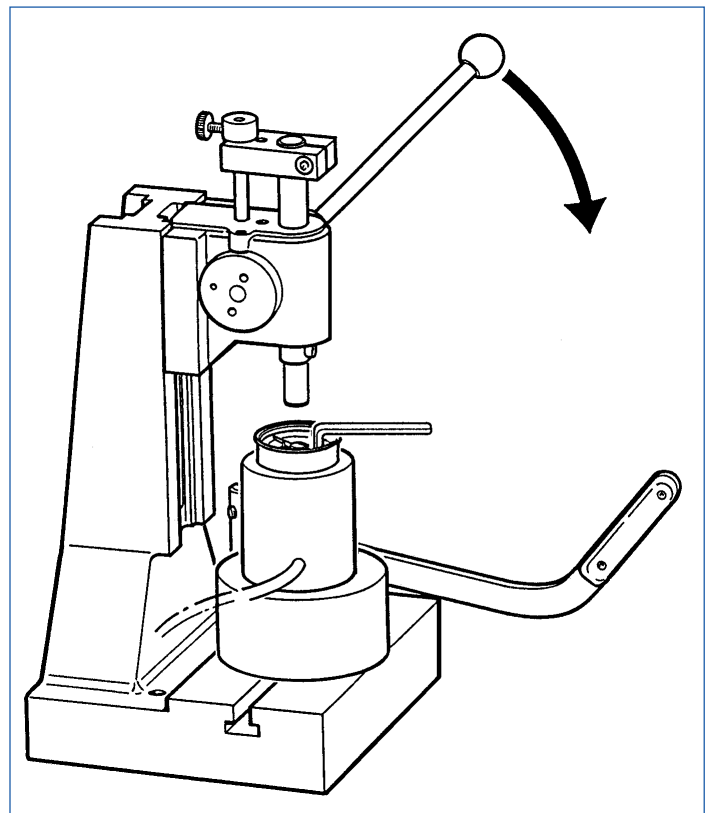
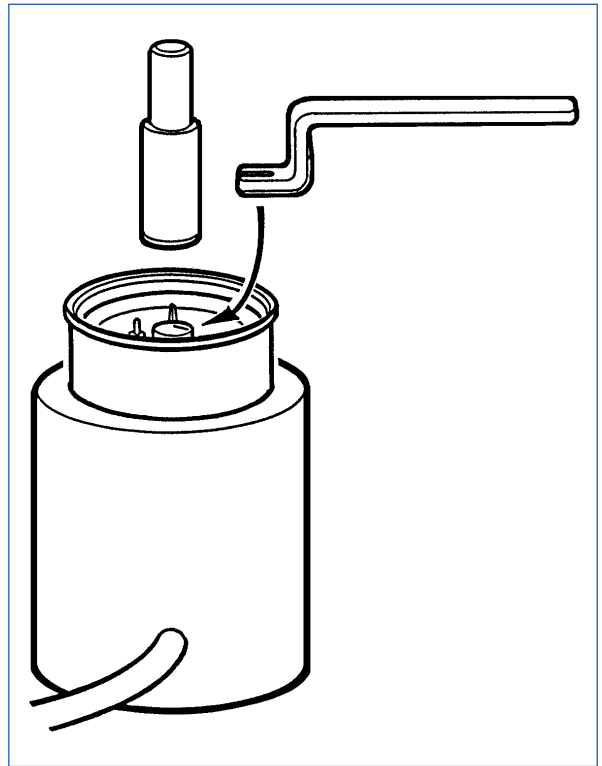

Technical Product Manual

VDO cockpit vision VDO cockpit international

17. Final Assembly

17.4 Assembly Sequence

17.4.4 Instruments 52 mm dia. VDO cockpit international (pressure gauge, temperature gauge, fuel level gauge, voltmeter)

Figure: example: pressure gauge - floodlight -

8. Insert deflector and lens (non-reflecting surface outwards).

Insert bezel.

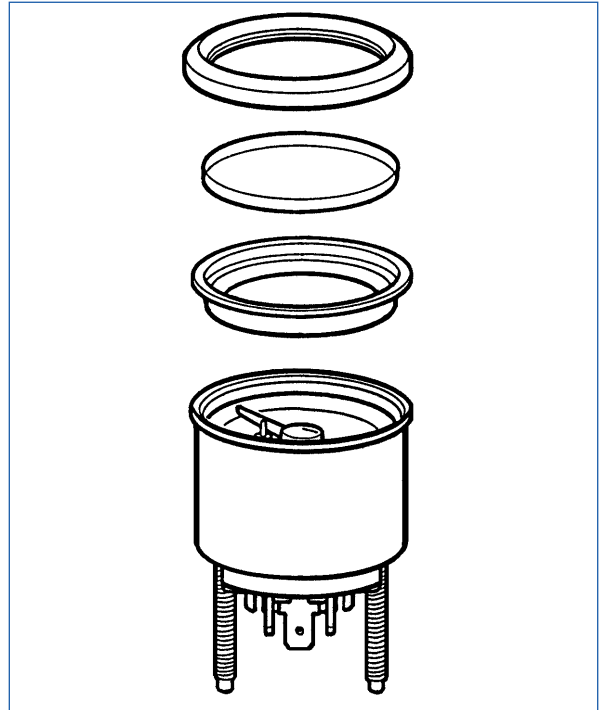

9. Place instrument on closing support and on the rotating fixture (or corresponding tool on the other closing tool), correctly place the pressure foot and the centering piece into correct position.

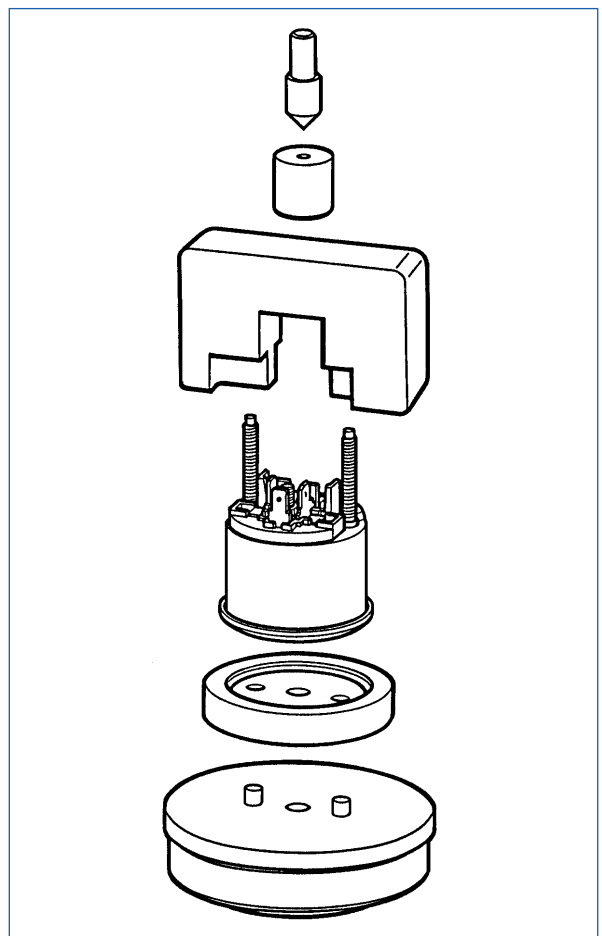

Technical Product Manual

VDO cockpit vision VDO cockpit international

17. Final Assembly

17.4 Assembly Sequence

17.4.4 Instruments 52 mm dia. VDO cockpit international (pressure gauge, temperature gauge, fuel level gauge, voltmeter)

Figure: example: pressure gauge - floodlight -

10. Use the universal press or an adequate rolling equipment to close the instrument.

In the case of the universal press guide the chasing lever so that the chasing wheel is parallel to the housing.

11. Check the indicating functions of the instrument according to the particular testing instructions in the chapters 6 to 10.
12. Add clamp ring or fixation set and 12 V or 24 V lamp bulbs per customer specification.
13. Mark with the workshop stamp on the rear side of the instrument (workshop No., month, year).

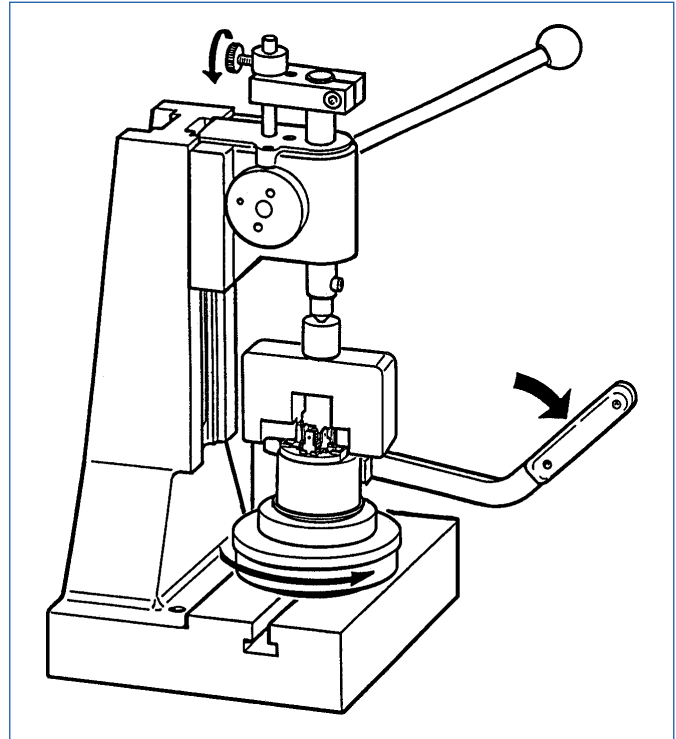

Technical Product Manual

VDO cockpit vision VDO cockpit international

18. Spare Parts And Accessories

Contents

Page

Mounting brackets, clamp rings

18 - 2

Illuminations, colour caps

18 - 3

Wiring kit, three-way socket

18 - 4

Female connector housing, blocking diode

18 - 5

Dropping resistor 24 V, reducing ring

18 - 6

Technical Product Manual

VDO cockpit vision VDO cockpit international

18. Spare Parts And Accessories

(in bag)

Mounting Brackets

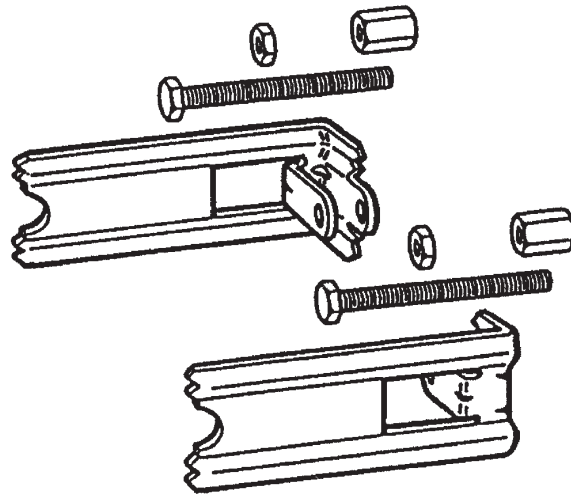

for instruments, dia. 80 mm / dia. 100 mm and
for tachometers, ammeters (150 Amp.), pyrometers and outside temperature gauges, dia. 52 mm

consisting of	Part No.
2x bracket	800-005-001G
2x hex screw (M4 x 45 ISO 4017)	
2x hex nut (M4 ISO 4032)	
2x nut (M4)	

Clamp Rings

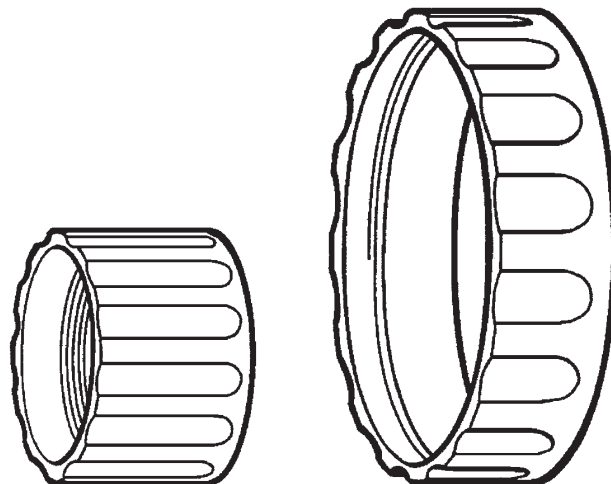

for instruments, dia. 52 mm / dia. 80 mm / dia. 100 mm

consisting of	Part No.
1x clamp ring, dia. 52 mm	800-005-015G
1x clamp ring, dia. 80 mm	800-005-005G
1x clamp ring, dia. 100 mm	800-005-007 G

Technical Product Manual

VDO cockpit vision VDO cockpit international

18. Spare Parts And Accessories

(in bag)

Illumination

Lamp holder for clip-in, thick light bulb

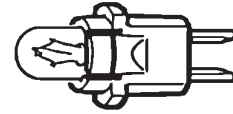

consisting of	Part No.
2x lamp holder with light bulb 12 V 2 W	800-005-002G
2x lamp holder with light bulb 24 V 2 W	800-005-003G

Illumination

Lamp holder for push-in, thin light bulb
for tachometers, ammeters (150 Amp.), pyrometers and outside temperature gauges, dia. 52 mm

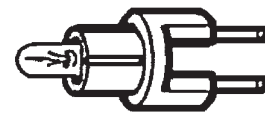

consisting of	Part No.
1x lamp holder with light bulb 12 V 1,2 W	800-005-019G

Colour Caps (VDO cockpit vision)



red and green for thick light bulb

consisting of	Part No.
2x colour cap, red	800-005-004G
2x colour cap, green	

Colour Caps (VDO cockpit vision)



red and green for thin light bulb

consisting of	Part No.
1x colour caps, red	800-005-014G
1x colour caps, green	

Technical Product Manual

VDO cockpit vision VDO cockpit international

18. Spare Parts And Accessories

(in bag)

Wiring Kit

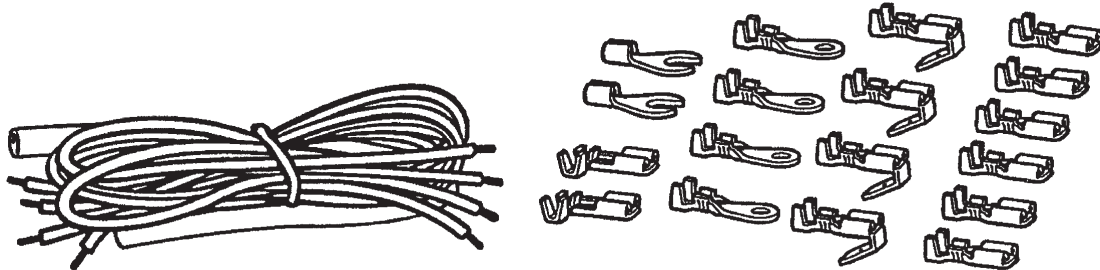

(not for ammeters)

consisting for	Part No.
6x spade connector	X11-000-005-037
4x plug distributor	
4x connecting eye	
2x open tongue terminal	
2x spade connector, angled	
1x cable, green (0.75 mm ²) 3000 mm	
1x cable, red (0.75 mm ²) 1500 mm	
1x cable, grey-red (0.75 mm ²) 1500 mm	
1x cable, brown (0.75 mm ²) 1500 mm	
1x insulating tube, black, 200 mm	

Three-way Socket For Tab Terminal

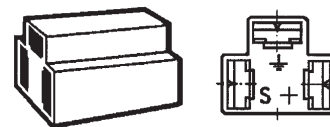

for pressure gauges, temperature gauges, fuel level gauges and voltmeters

consisting of	Part No.
100x female connector housing, three-way, grey	999-115-015

Technical Product Manual

VDO cockpit vision VDO cockpit international

18. Spare Parts And Accessories

(in bag)

Female Connector Housing, Two-way

for lamp holder with thick light bulb

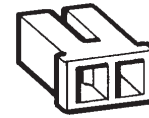

consisting of
100x female connector housing, two-way, light grey

Part No.
999-115-150

Female Connector Housing, Eight-way

for speedometers and tachometers,
dia. 80 mm / dia. 100 mm

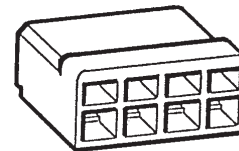

consisting of
100x female connector housing, eight-way, colourless

Part No.
999-115-016

Spade Connector 6.3 x 0.8 mm

for all female connector housings



consisting of
100x spade connector with snap-in hooks

Part No.
X11-000-002-021

Blocking Diode

for tachometers
(see SI No. 402 001)



consisting of
1x blocking diode

Part No.
X11-397-109-134

Technical Product Manual

VDO cockpit vision VDO cockpit international

18. Spare Parts And Accessories

(in bag)

Dropping Resistor 24 V Kit for VDO cockpit vision

for tachometers, dia. 52 mm and
outside temperature gauges, dia. 52 mm

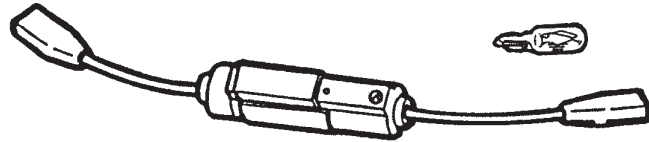

consisting of	Part No.
1x dropping resistor (24 V)	800-005-011G
1x light bulb (24 V 1.2 W)	

Dropping Resistor 24 V Kit for VDO cockpit international

for tachometers, dia. 52 mm,
ammeters (150 Amp.), dia. 52 mm,
pyrometers, dia. 52 mm and
outside temperature gauges, dia. 52 mm

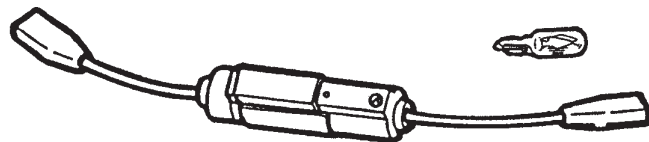

consisting of	Part No.
1x dropping resistor (24 V)	800-005-011G
1x light bulb (24 V 2 W)	

Reducing Ring

from dia. 60 mm to dia. 52 mm

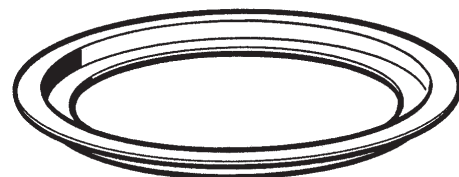

consisting of	Part No.
1x reducing ring, black	14-067-014-5162

Technical Produkt Manual

VDO cockpit vision VDO cockpit international

19. Pyrometer

Exhaust-gas Temperature Measuring System (dia. 52 mm)
(only for VDO cockpit international)

Contents

Page

19.1 General informations	19 -2
19.2 Technical data (indicator unit)	19 -3
19.3 Technical data (temperature sensor, connecting cable, threaded bushing)	19 -4
19.4 Temperature sensor	19 -5
19.5 Wiring diagram	19 -7
19.6 Dropping resistor for 24 V	19 -8
19.7 Systems survey	19 -9

Installation instructions

999-165-026: VDO cockpit international

see file 'Installation Instructions (MA)'.

Technical Produkt Manual

VDO cockpit vision VDO cockpit international

19. Pyrometer

Exhaust-gas Temperature Measuring System (dia. 52 mm)
(only for VDO cockpit international)

19.1 General Informations

The exhaust-gas temperature measuring system has been designed for landbound vehicles (with the exception of motorcycles) or stationary systems only.

The pyrometer serves to monitor accurately the temperature in the elbow flange of the exhaust pipe and indicates eventual thermal overload of the engine.

A temperature sensor installed in the exhaust pipe measures the exhaust temperature and transmits the data (100°C to 900°C) to an analog indicator unit (turning magnet ratio measuring movement, pointer deflection up to 320°: designation of function see tachometer, dia. 52 mm).

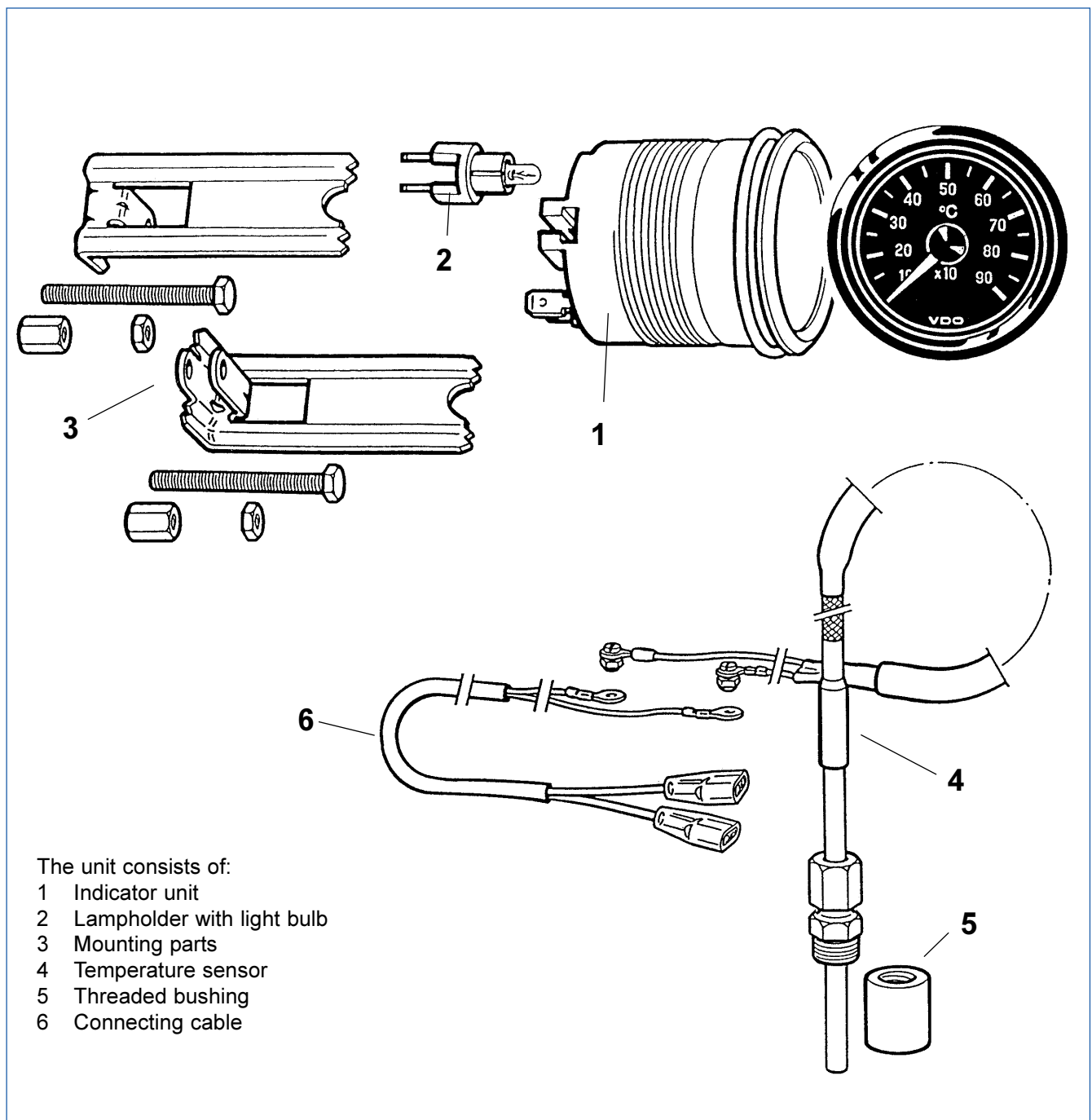

Technical Produkt Manual

VDO cockpit vision VDO cockpit international

19. Pyrometer

Exhaust-gas Temperature Measuring System (dia. 52 mm)
(only for VDO cockpit international)

19.2 Technical Data (Indicator Unit)

Temperature gauge, electronic

(Instrument separate not available. Only as set.)

Operating voltage:	10.8 ... 16 V
Movement:	System Ke (\rightarrow 320°C)
Current consumption:	< 100 mA (without illumination)
Operating temperature:	- 20°C ... + 70°C
Storage temperature:	- 30°C ... + 85°C
Illumination:	1 light bulb 12 V, 2 W
Protection:	IP64 DIN 40050 from the front
Connections:	reverse-polarity protection
Vibration resistance:	max. 1g eff., 25 ... 500 Hz, duration 8 h, f: 1 octave/min.
Nominal position:	NL 0 to NL 90, DIN 16257

VDO cockpit international

dia. 52 mm Floodlight

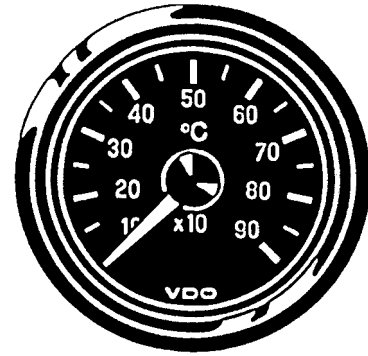

Mounting hole: dia. 53mm

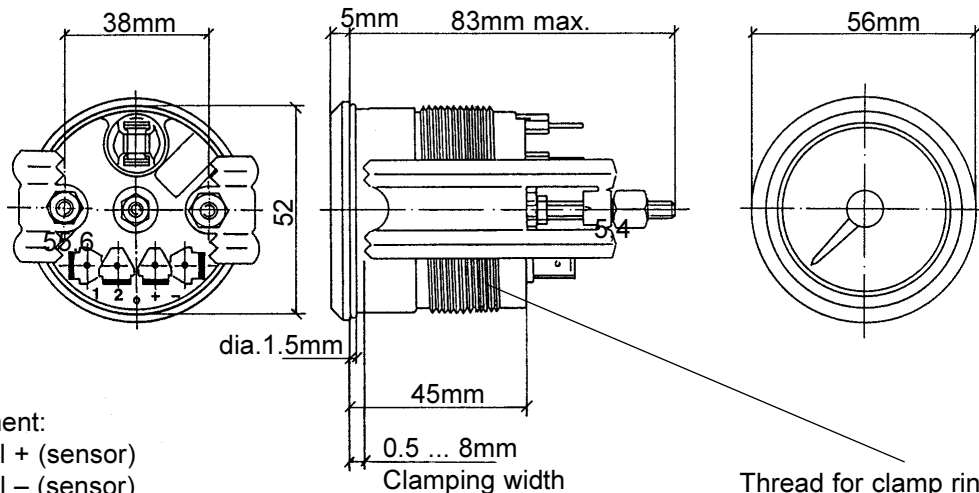

Pin assignment:

Pin 1: Signal + (sensor)

Pin 2: Signal - (sensor)

Pin +: + 12 V, terminal 15

Pin -: Ground, terminal 31

Thread for clamp ring (option)
(clamping width:
0,5 ... 12 or 12 ... 23mm)

Technical Produkt Manual

VDO cockpit vision VDO cockpit international

19. Pyrometer

Exhaust-gas Temperature Measuring System (dia. 52 mm)
(only for VDO cockpit international)

19.3 Technical Data (Temperature Sensor, Connecting Cable, Threaded Bushing)

Temperature sensor 2pole (insulated return)

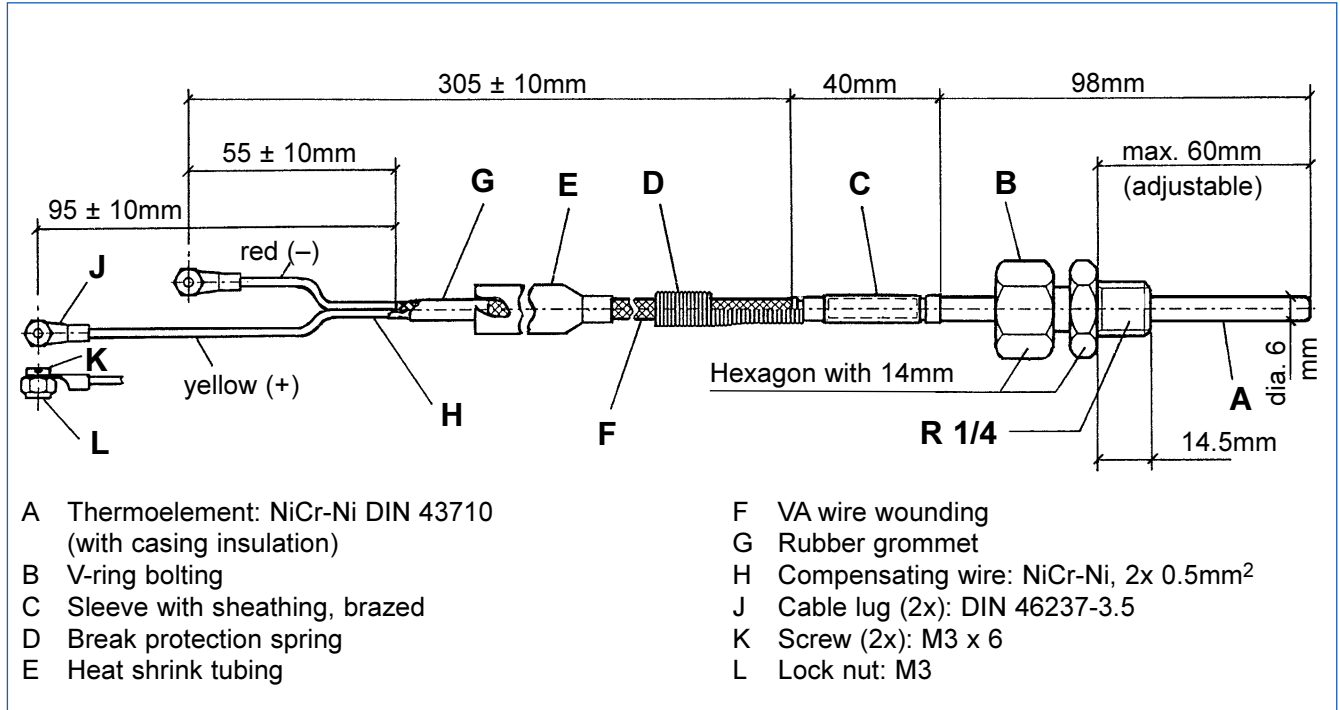

Connecting cable

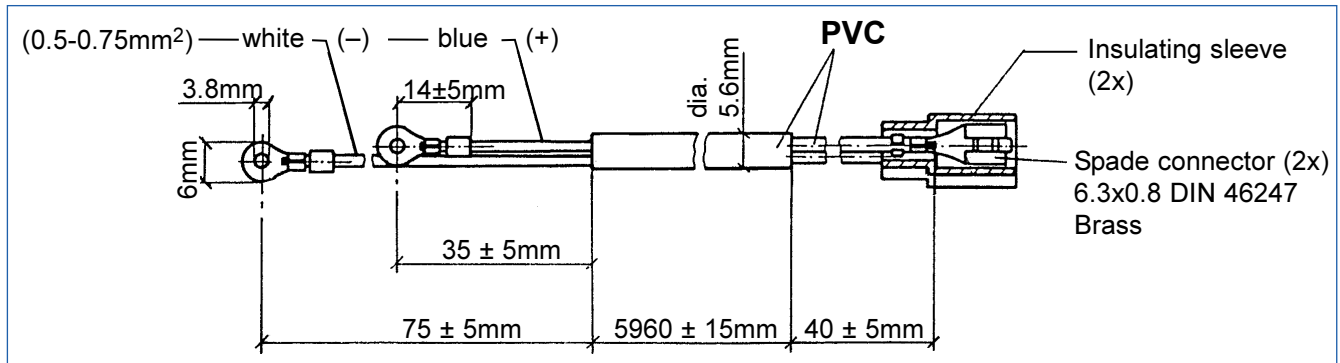

Threaded bushing (steel)

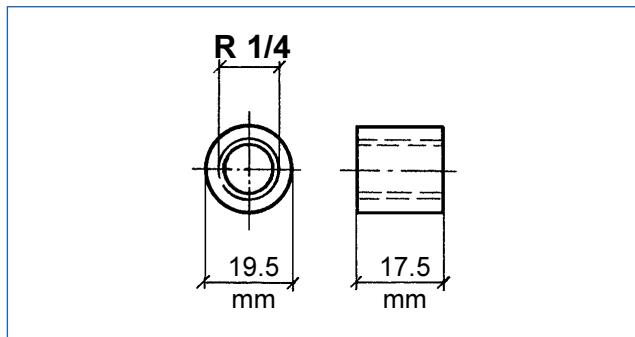

Technical Produkt Manual

VDO cockpit vision VDO cockpit international

19. Pyrometer

Exhaust-gas Temperature Measuring System (dia. 52 mm)
(only for VDO cockpit international)

19.4 Temperature Sensor

The temperature sensor needed to operate the pyrometer is supplied with threaded bushing and connecting cable.

Install the temperature sensor in the exhaust pipe near the elbow flange.
Mounting hole: dia. 10 mm.
Mount the threaded bushing centrally and weld on.



The weld must form a tight seal.
Always follow the safety instructions and advice of the welding equipment manufacturer.

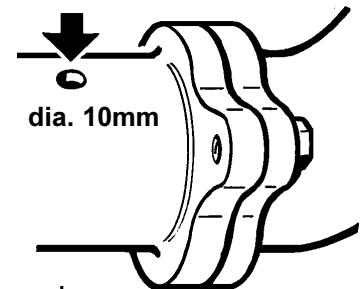

dia. 10mm

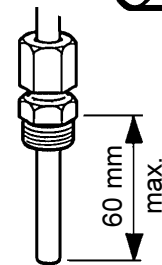

60 mm
max.

R 1/4

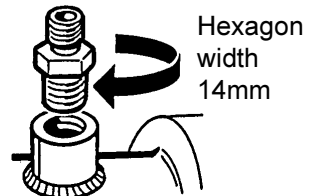
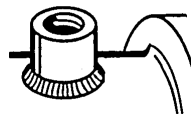
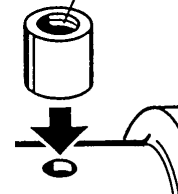

Hexagon
width
14mm

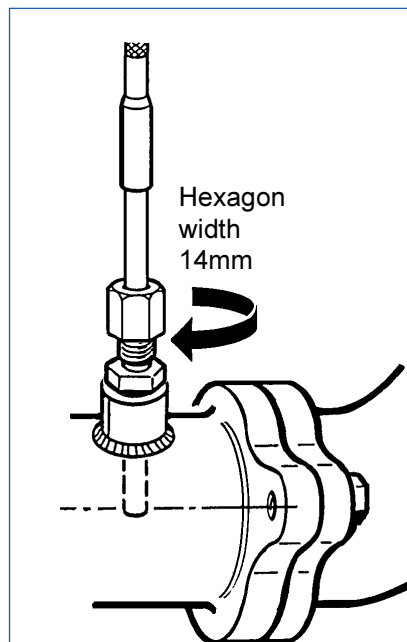

Hexagon
width
14mm



Adjustment depth up to the middle of exhaust pipe (max. 60 mm).

Technical Produkt Manual

VDO cockpit vision VDO cockpit international

19. Pyrometer

Exhaust-gas Temperature Measuring System (dia. 52 mm)
(only for VDO cockpit international)

19.4 Temperature Sensor

Connect the white cable of the temperature sensor with the red cable of the connecting cable and the yellow cable of the temperature sensor with the blue cable of the connecting cable.

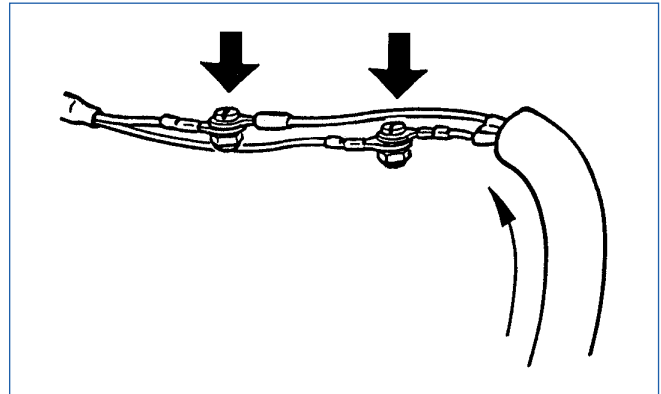

Slide the heat shrink tubing over the cable connections and then heat with a hot-air fan over the entire length until it shrinks.



Always follow the safety advice of the hot-air fan manufacturer.

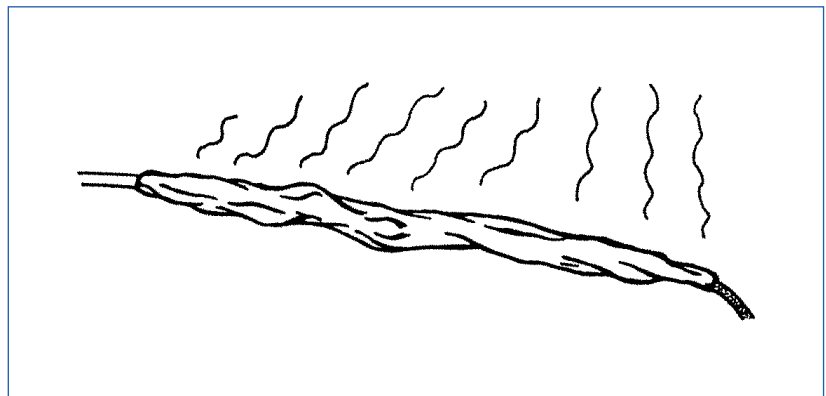

Do not shorten the connecting cable (measuring lead).

Technical Produkt Manual

VDO cockpit vision VDO cockpit international

19. Pyrometer

Exhaust-gas Temperature Measuring System (dia. 52 mm)
(only for VDO cockpit international)

19.5 Wiring Diagram

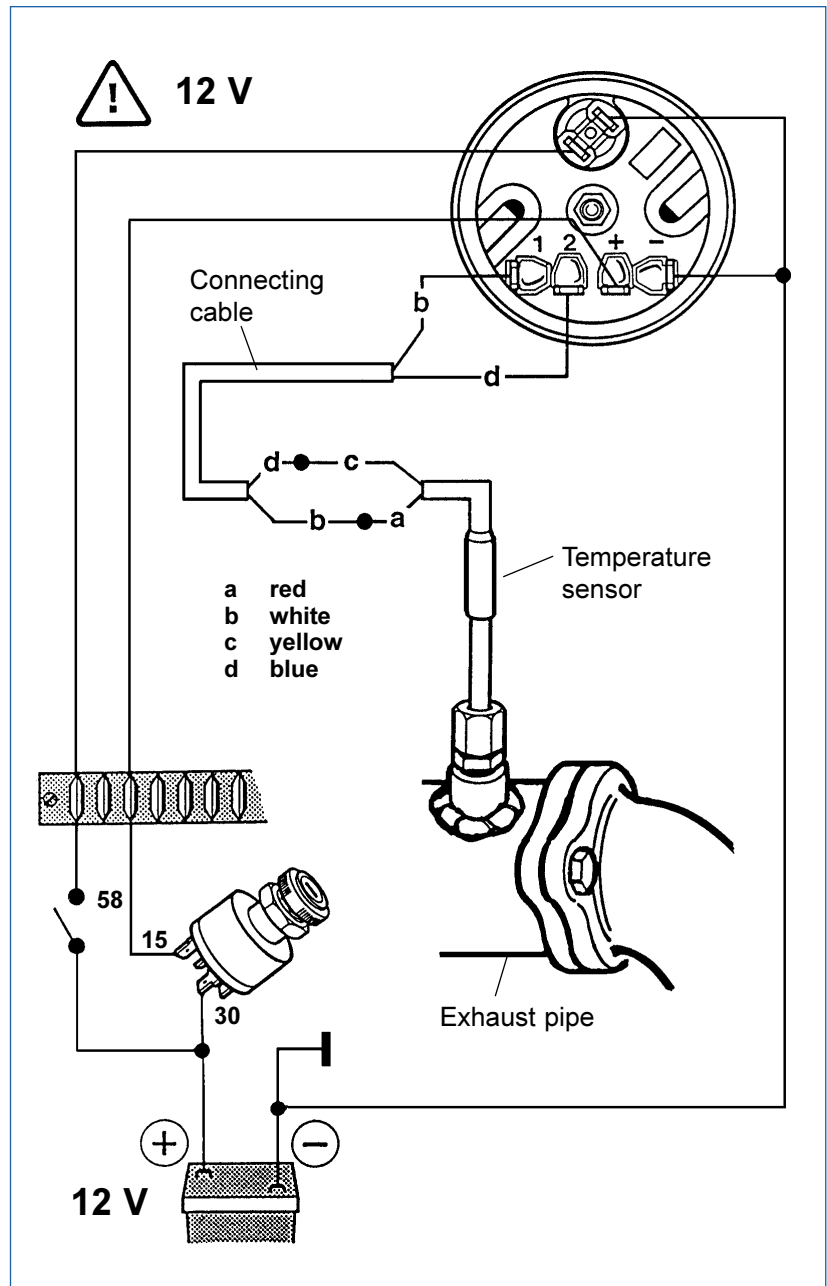

Do not shorten the connecting cable (measuring lead).

Technical Produkt Manual

VDO cockpit vision VDO cockpit international

19. Pyrometer

Exhaust-gas Temperature Measuring System (dia. 52 mm)
(only for VDO cockpit international)

19.6 Dropping Resistor For 24 V

The electronic exterior temperature indicating instrument (rated voltage 12 V) can also be used with a rated voltage of 24 V if an external dropping resistor (option) is installed in the plus wire (terminal 15). In this case the operating voltage can be 21 V to 32 V.



Replace 12 V light bulb by a 24 V light bulb.

The dropping resistor is supplied with a 24 V 2 W light bulb.
Part No.: 800-005-027G

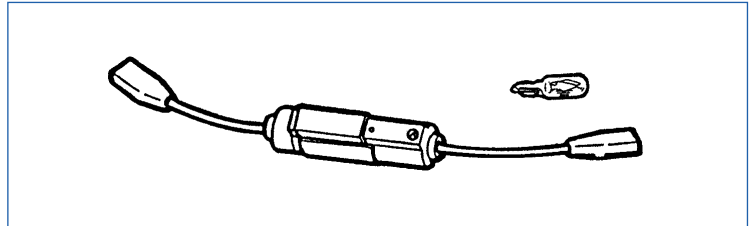

Wiring diagram



Do not shorten the connecting cable (measuring lead).

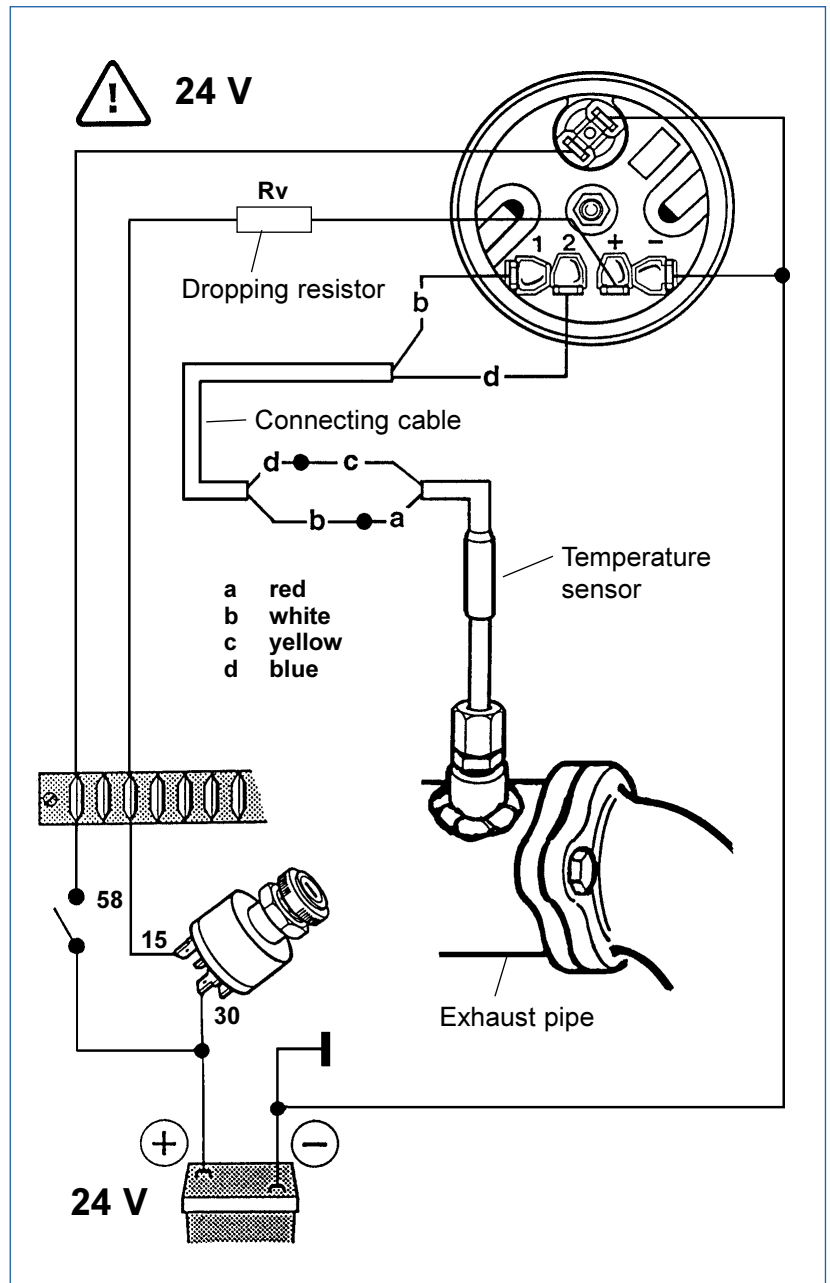

Technical Produkt Manual

VDO cockpit vision VDO cockpit international

19. Pyrometer

Exhaust-gas Temperature Measuring System (dia. 52 mm)
(only for VDO cockpit international)

19.7 Systems Survey

VDO cockpit international (Floodlight) dia. 52 mm

Part No. 397-015-. . .

Dial		Special feature	Part No.
Range	Imprint		
100°C ... 900°C	10 ... 90 x10 °C	12 V	003C

Technical Product Manual

VDO cockpit vision VDO cockpit international

Change View

Date	Chapter-Page	Comment
0200	—	New issue, supersedes Technical Product Manual VDO Instruments chapter A Round VDO Instruments chapter B Confectioning of Round VDO Instruments (TU00-0777-0000002)
0600	general	Installation Instruction: <i>removed</i> : ▼ will follow
	15 - 4	Protection: IP64 <i>was</i> IP40
	14 - 5, - 6	<i>removed</i> : temperature sensor, insulated return
0101	5 - 5, 14 - 5	Light bulb: 2W <i>was</i> 1.2 W, dropping resistor: 2W <i>was</i> 1.2 W
	5 - 8, 14 - 7	<i>new</i> : dropping resistor VDO cockpit international
	18 - 6	<i>new</i> : dropping resistors
	15 - 4	500 Hz <i>was</i> 2000 Hz
0301	3 - 10, 5 - 9, 5 - 10	<i>new</i> : 5 cylinders, text coding table
	13 - 1 to 13 - 7	<i>new</i> : 331-810-012-....
	19	<i>complete new</i>
0601	17 - 15, 17 - 17	Pos. 16: dia. 100mm 999-071-003 <i>was</i> 999-075-003
	17 - 22, 17 - 24, 17 - 26	Pos. 15: dia. 100mm 999-071-003 <i>was</i> 999-075-003
0801	7-12	<i>new</i> : table 60 to 200°C
	2-4 to 2-7, 3-4 to 3-7, 4-4 to 4-5	<i>new</i> : EMC test: according to EN 13309 and ISO 13766
0102	12 and 13	<i>new</i> : new generation (illustrations and text)
0502	13-4	<i>new</i> : 18V to 28V, Pin KL 58
	13-7	331-810-012-004B <i>was</i> -004, -007B <i>was</i> -007
0902	5-16	<i>new</i> : 029C: with clamp ring, 029G: with stud bolt
0503	2-9	<i>new</i> : pin allocation hall sensor
0704	9-11	Deflection (°Δ) 24, 48, 67 <i>was</i> 22, 44, 66
	12-8	Part No. -031- <i>was</i> -021-